



## HOMMEL-ETAMIC AG200

Air tooling for measurement of outside diameters



Precision is our business.



## Your partner for industrial metrology

Hommel-Etamic, the Industrial Metrology Division of the Jenoptik group is a leading manufacturer and system provider of high-precision, tactile and non-tactile production metrology.

The range of products provided includes total solutions for a wide range of measurement tasks such as testing surfaces, form and determining dimensional tolerances – throughout all phases of the production process, for final inspection or in a metrology lab. Our product portfolio is rounded off by a wide range of services in consulting, training and service, including long-term maintenance contracts.

Hommel-Etamic. Precision is our business!

### Pneumatic precision — HOMMEL-ETAMIC AG200

Hommel-Etamic has been successfully developing and manufacturing pneumatic (air) tooling for over 60 years and our impressive global sales figures in this industry speaks for itself.

Thanks to modern day materials technology Hommel-Etamic air rings are extremely robust, making them ideal for measuring workpieces that are subject to extremely harsh manufacturing and operating conditions (e.g. nuclear, automotive, aviation, medical, etc). In addition, our application of the pneumatic principle (high pressure) eliminates any special maintenance processes – a simple cleaning is all the tooling requires.

In addition to a wide range of standardized air tooling, Hommel-Etamic develops and manufactures part-specific air tooling for a wide range of manufactured parts, either of which can be modified for the number, type, and position of the air jets.

# Tooling with open air jets for diameter measurement of shafts

## Reliability and quality

Hommel-Etamic air rings are extremely reliable, and in terms of precision and repeat accuracy (below  $0.25\ \mu\text{m}$ ), can outperform comparable tactile gauging systems. Precision manufacture of each ring is held to such a tight tolerance that the rings can be replaced without compatibility issues, making it easy to verify gauging component capability.

## Static or dynamic measurements

AG200 air tooling are primarily used to measure diameters of continuous or shouldered shafts. The diameter is established using two or three non-contact air jets, offset against the inner guide diameter of the air ring. Measurements can take place either statically or dynamically.

## Mounted or mobile operation

AG200 air rings can be used hard mounted inline or on a bench, as well as on semi-portable handles for operational flexibility. Part insertion is simplified using mathematically calculated diameters based off the measuring range of the air tooling.

## Extremely robust

Hommel-Etamic air rings are recommended for workpieces made with circular grinding machines (center-

less or plunge-cut). Robust in design and manufacture, AG200 air tooling can be used to measure hundreds of thousands of workpieces with no loss in measuring accuracy. Each one is manufactured from either hardened steel (59/62 HRC) or surface-treated steel (54/57 HRC) for diameters down to 20 mm, or carbide-coated steel for diameters between 3-20 mm, making them particularly suitable for use in harsh manufacturing environments.

## Simple calibration

The impressive linearity of Hommel-Etamic measuring chains allows AG200 systems to be calibrated using only one master, making the use (and expense) of maximum and minimum masters unnecessary.

## Universal application

AG200 air tooling is ideal for manual measurement of shafts in production lines, for automatic or semi-automatic measuring stations, and for the quality lab (subgroups or 100% monitoring).

## Error measurement

Workpieces can be rotated in the AG200 air ring to determine out-of-roundness and advanced through the ring to determine conicity. On request, the air ring can be fitted with additional air jets for increased measurement capability, such as X and Y diameter measurement, ovality, etc.

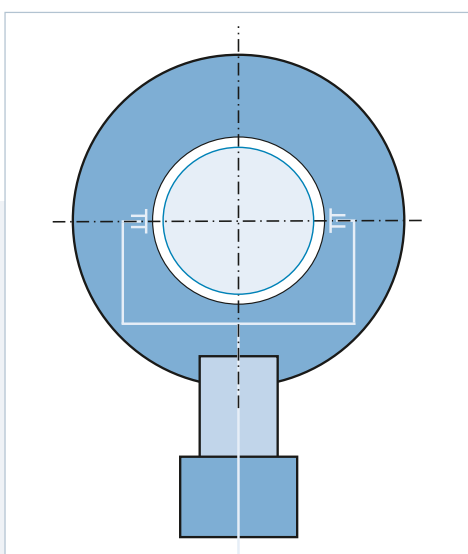

Measuring principle

## Application examples

- Axle drive shaft
- Gear box shaft
- Drive blade
- Injector needle
- End section of camshafts
- End section of crankshafts
- Piston axis etc.

# Wide range of air tooling

Our standard air tooling sizes range from 3 mm to 150 mm in diameter, with measuring ranges of 0.010 mm to 0.160 mm respectively (typically measuring ranges should be at least equal to, or double, the size of the tolerance for the shaft to be measured).

## Two or three jets according to the measuring task

There are two different standard versions of AG200 air rings. One with two jets diametrically opposed for diameter and out-of-roundness (round # 1, round # 2 or elongated # 5) or the other with three jets at 120° for measurement of average diameter and triangulation (round # 0.7 or round # 1.5).

The type of jets used depends on the diameter, the surface structure of the workpiece to be measured, and the required measuring range (i.e. elongated air jets are used to reduce the impact of surface roughness on the measurement result).

The position of the air jets depends on the type of ring being used. There are two types of tooling: 'S' (standard, with centered jets for continuous shafts) or 'TP' (jets located near the ring end for shouldered shafts). All Hommel-Etamic air tooling has a unique identifier engraved on them.

## Applications with Hommel-Etamic measuring instruments

AG200 air rings can be connected to all standard Hommel-Etamic measuring instrumentation. In the case of portamic, C61, and pneumatic displays, the AG200 air rings are directly connected to each device.

Alternatively, they can be used indirectly via an electro pneumatic converter (ARC99, TPE99 or TPE70/3). In this case, the measurement results can be displayed on an ESZ800, CMZ200, CMZ250 or ESZ400 industrial controller.



Use with HOMMEL-ETAMIC pneumatic



Use with HOMMEL-ETAMIC CMZ200

# Properties of standard air rings

Measuring range and min.  $\varnothing N$ :  
two jets (centered or near the end)

Diameter (mm)	Jet type		
	Round # 1	Round # 2	Elongated # 5
$3 \leq \varnothing N < 6$	Maximum measuring range = 0.080	Maximum measuring range = 0.160	Not available
$6 \leq \varnothing N \leq 150$	Maximum measuring range = 0.080	Maximum measuring range = 0.160	Maximum measuring range = 0.080
min. $\varnothing N$	3 mm	4 mm	8 mm

Measuring range and min.  $\varnothing N$ :  
three jets (centered or near the end)

Diameter (mm)	Jet type	
	Round # 0.7	Round # 1.5
$3 \leq \varnothing N \leq 150$	Maximum measuring range = 0.040 mm	Maximum measuring range = 0.120 mm
min. $\varnothing N$	3 mm	3 mm

## Precision and performance

The outstanding precision delivered by our products supports compliance with the most stringent performance standards: CMC, GR&R, Cg, Cgk etc.

Measuring range (mm)	Accuracy	Performance	
		GR&R type 2	CMC
0.010 ( $\pm 0.005$ )	< 0.00025	< 10%	2
0.020 ( $\pm 0.010$ )	< 0.0005		
0.040 ( $\pm 0.020$ )	< 0.001		
0.060 ( $\pm 0.030$ )	< 0.0015		4
0.080 ( $\pm 0.040$ )	< 0.002		
0.120 ( $\pm 0.060$ )	< 0.003		
0.160 ( $\pm 0.080$ )	< 0.004		

# Properties of standard air rings

## Guide diameter

The guide diameter is the actual diameter of the air ring. It depends on the selected capacity, jet type, and the nominal diameter of the dimension to be measured.

Measuring range (mm)	Guide diameter with					Tolerance (mm)
	2 round # 1	2 round # 2	2 elongated # 5	3 round # 0.7	3 round # 1.5	
0.010 (±0.005)	ØN + 0.012	ØN + 0.012	ØN + 0.012	ØN + 0.012	ØN + 0.012	±0.002
0.020 (±0.010)	ØN + 0.018	ØN + 0.020	ØN + 0.020	ØN + 0.018	ØN + 0.020	±0.003
0.040 (±0.020)	ØN + 0.030	ØN + 0.035	ØN + 0.035	ØN + 0.030	ØN + 0.035	±0.005
0.060 (±0.030)	ØN + 0.040	ØN + 0.045	ØN + 0.045	–	ØN + 0.045	±0.005
0.080 (±0.040)	ØN + 0.050	ØN + 0.055	ØN + 0.055	–	ØN + 0.055	±0.005
0.120 (±0.060)	–	ØN + 0.075	–	–	ØN + 0.075	±0.005
0.160 (±0.080)	–	ØN + 0.095	–	–	–	±0.005

## Overview of standard air tooling



ØN (mm)	A	B
ØN < 10	53.5	50
10 ≤ ØN ≤ 20	58.5	60
20 ≤ ØN ≤ 30	63.5	70
30 ≤ ØN ≤ 40	68.5	80
40 ≤ ØN ≤ 50	73.5	90
50 ≤ ØN ≤ 60	78.5	100
60 ≤ ØN ≤ 80	88.5	120
80 ≤ ØN ≤ 100	98.5	140
100 ≤ ØN ≤ 120	108.5	160
120 ≤ ØN ≤ 140	118.5	180
140 ≤ ØN ≤ 150	128.5	200

# Overview of standard air tooling

## Rings 'S' with 2 standard jets

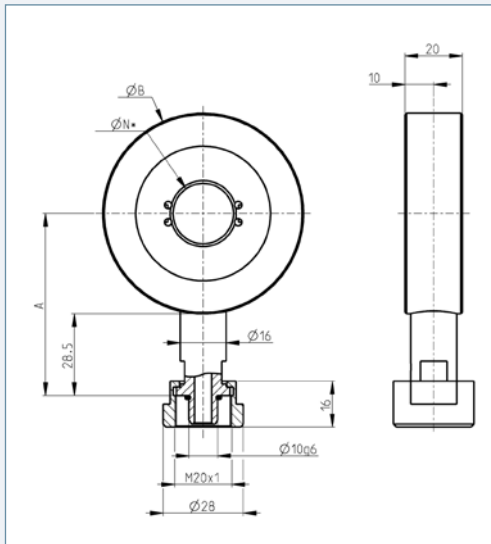

AG200-S2-3-150; diameter  $3^* \leq \varnothing N \leq 150$  mm

## Rings 'TP' with 2 jets near the end

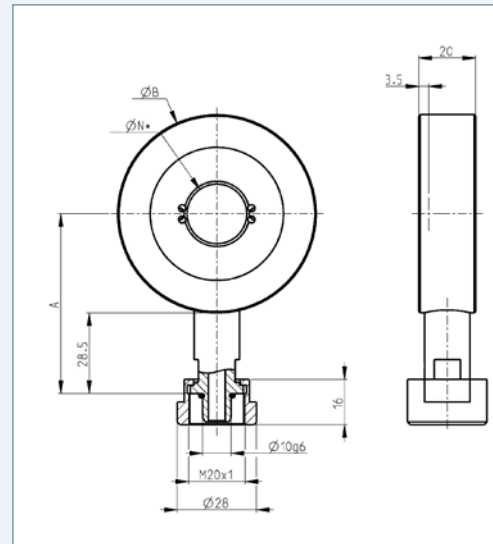

AG200-TP2-3-150; diameter  $3^* \leq \varnothing N \leq 150$  mm

## Rings 'S' with 3 standard jets

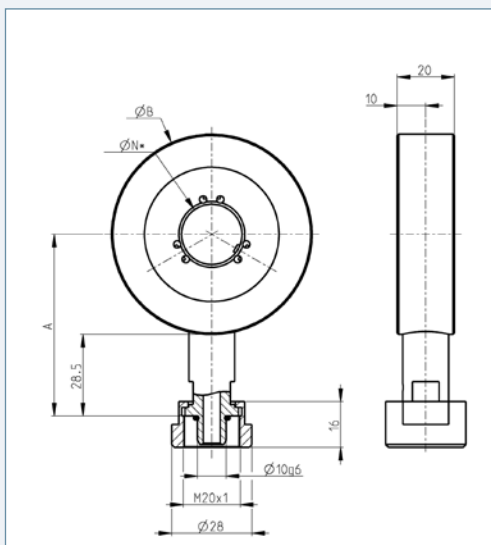

AG200-S3-3-150; diameter  $3^* \leq \varnothing N \leq 150$  mm

## Rings 'TP' with 3 jets near the end

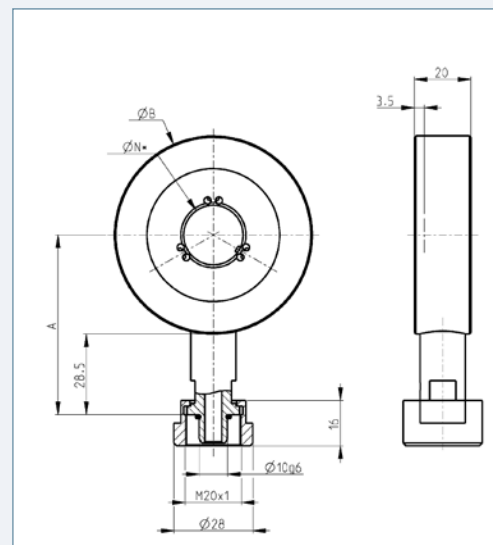

AG200-TP3-3-150, diameter  $3^* \leq \varnothing N \leq 150$  mm

\*  $\varnothing N$  min. depends on the jet (see table page 5).

# Accessories

Handle with flexible hose and M20x1 plug-in connection

The handle makes it possible to use the air ring manually and makes handling, with or without protective gloves, simpler. The type of flexible hose required is determined on the basis of which pneumatic design the air ring features:

Hose length/ hose diameter	1 m	1.5 m
4 mm	E500096-100	E500096-150
5 mm	E500097-100	E500097-150
6.5 mm	E500098-100	E500098-150
8 mm	E500099-100	E500099-150



Spindle extension M20x1 plug-in connection-  
M20x1 socket

For taking measurements of workpieces that are hard to access.

E500073-000



Adapter M14x1 plug-in connection-M20x1  
plug-in connection

Facilitates fitting of the latest-generation air rings to a C61 display unit or a TPE70 converter (screw thread M14x1).

E501000-000



Adapter 1/4 BSP plug-in connection-M20x1  
plug-in connection

Facilitates direct connection of an air ring to a TPE99 converter or a pneumatic display unit (screw thread 1/4 BSP).

E500069-000



O ring

For sealing the connection between the ring nut and the handle connection piece, the adapter or the base.

X470004-153



Replacement nut M20x1 socket

E500070-000





# Accessories

## V-shaped guide

The V-shaped guide for air rings facilitates the introduction of the workpiece (continuous shafts) into the air ring hole. A carbide-coating protects the guide at places where it is in contact with the workpiece. It is available for diameters from 3-60 mm. In case of long workpieces, the V-shaped guide can be on both sides of the air ring (see picture below).

E502700-000

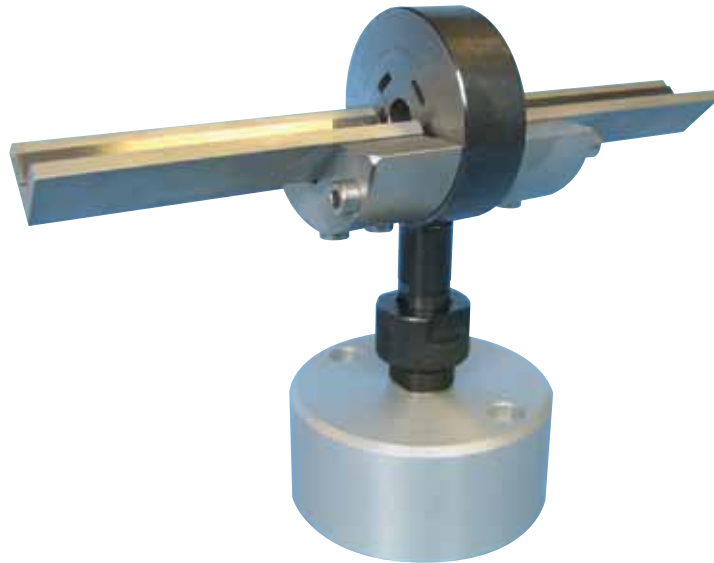

## Workpiece ejector

The ejector is used when the workpiece to be measured is very short (less than 25 mm) in order to make the ejection easier.

Ejector for  $6 \leq \varnothing N < 10$  E502811-000

Ejector for  $10 \leq \varnothing N < 20$  E502812-000

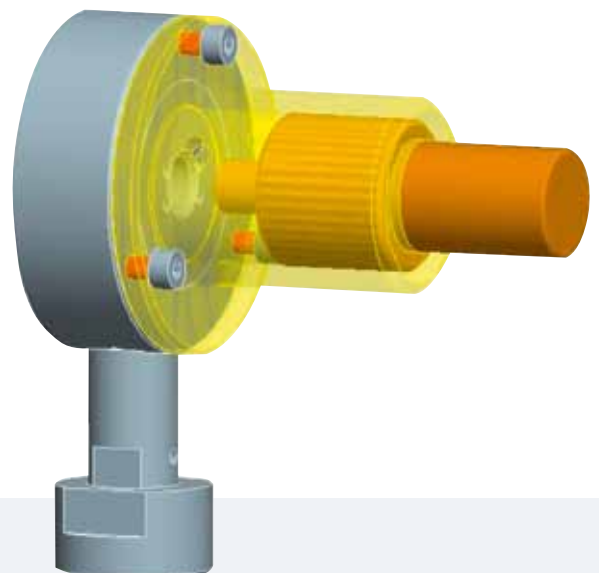

# Accessories

## Storage device

Used for storing the air ring when not in use. This accessory can also be fitted with an available air saving device featuring a switch-controlled pneumatic valve that automatically turns the air supply off or on.

## Storage device

E501194-000

## Storage device with pneumatic switch

E501194-050

## Air ring base

Used if the workpiece to be measured is light, as the measurements should ideally be performed using a ring that is attached to a table. Secured using two M6 bolts and available in two versions:



90° base  
E500119-000



45° base  
E500119-002

## Air ring base with jet block

Reduces the pneumatic response time between the ring and the controller, when performing dynamic measurements.

## 90° base with jet block

E500119-001

## 45° base with jet block

E500119-003



Storage device

## Examples of air tooling mounted on a base





Air ring with centered round jet ,S' and respectively round or elongated jet located near the ring end ,TP'.

## Air ring selection

To ensure the selection of the ideal air ring for your application, the following information is required:

- Drawing of the workpiece to be measured
- Diameter, tolerance, and surface structure of the shaft to be measured
- Type of shaft (continuous or shouldered)
- Type of material required for the air ring: hardened steel (100,000 workpieces to be measured) or surface-treated steel (1,000,000 workpieces to be measured)
- Required measuring range (see measuring range table on page 5)
- Pneumatic combination, if the air ring is to be connected to an existing device

Our specialist consultants will be happy to answer any questions you may have, to help you determine which air spindle is best suited for your application.

We look forward to hearing from you!

HOMMEL-ETAMIC France SA  
ZA Damigny, Rue de la Cartoucherie  
Saint-Martin-des-Entrées, BP 61080  
14406 Bayeux Cedex, France  
Phone +33 231 51 3751  
Fax +33 231 21 1361  
E-Mail [info.fr@hommel-etamic.com](mailto:info.fr@hommel-etamic.com)



## Our global presence.

Germany	Spain	Mexico
France	Czech Republic	China
Switzerland	United States	South Korea
		India

Group companies, affiliates and representation worldwide

[www.hommel-etamic.com](http://www.hommel-etamic.com)