



User Manual

3DP1000

www.3DPlatform.com

About the 3DP1000

Robust SIMO® Series linear actuators from PBC Linear® provide smooth and accurate motion control

Dual extruders with filament sensors

A. NEMA 23 stepper motors with integrated amplifier and 800 microstepping

Z Axis—500 mm

Print bed with heated borosilicate glass

Y Axis—1000 mm

Printers purchased after 12-4-15 have emergency shut-offs on the front and the rear of the machine

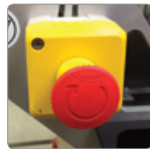

B. Upgrade option to step-servo motors with SurePrint™ Technology



Safety guards are placed in multiple locations

USB connectivity to computer



X Axis—1000 mm

Industrial rolling casters

1. Electrical panel located inside finished industrial cart.
2. Printer information including serial number located inside the electrical panel.

LCD control unit with SD card slot

- A. Printers purchased prior to 12-4-15 have the temperature control unit for the print bed located here.
- B. Printers purchased after 12-4-15 operate the temperature of the print bed through the LCD control unit or with 3D printing software. Power on/off buttons are located here.

PRODUCT DESCRIPTION

The 3DP1000 is designed to comply with CE standards. The 3DP1000 3D printer is manufactured by 3D Platform, located in Roscoe, Illinois USA. 3D printing, or additive manufacturing, is a process of making three-dimensional objects of a variety of shapes and sizes from a digital model. 3D printing is achieved using an additive process, where successive layers of material are heated and melted at the nozzle, extruded and laid down on the build platform—also known as Fused Filament Fabrication (FFF). The printer is capable of using any material manufactured for FFF type 3D printing, provided the melt temperature and print bed temperature requirements are within the specifications of the 3DP1000 outlined in this manual.

The 3DP1000 is capable of carrying out the additive manufacturing process under open source controls, via 3D model output in the .gcode format. It can be operated using the USB computer interface or independently with the LCD control unit and SD card.

Table of Contents

| | | | |
|--|--------------------|---|-------------------|
| Product Description | Inside Front Cover | LCD Control Unit Operation | 16 |
| Safety | 2 | Loading and Changing Filament | 17 |
| Safety Features | 2 | Printing Via SD Card | 17 |
| First Aid. | 2 | Printing Via USB Connection with Computer | 17 |
| Safety Guidelines | 2 | Care and Maintenance | 18 |
| Symbols and Warning Labels | 3 | Preparing the Print Bed | 18 |
| Intended Use | 3 | Clearing the Hob | 18 |
| Technical Specifications | 4 | Cleaning the Nozzle. | 19 |
| Source Code for Control System | 4 | Changing the Nozzle | 19 |
| Electrical Voltage and Plugs | 4 | Wiring Diagram. | 20 |
| Crate Contents | 5 | Calibration and Test Prints | 21 |
| Unpacking the Printer | 5 | Supplied Files and Suggested Print Settings | 21 |
| Installation of Driver and Software. | 6 | Printing Tips | 22 |
| Initial Printer Setup | 7 | Measuring Filament | 22 |
| Actuator Alignment | 7 | The Importance of Temperature | 22 |
| Powering Up | 7 | Seasoning the Nozzle | 22 |
| Sensor Verification. | 8 | Z-Gap and Z-Offset | 23 |
| USB Connection | 8 | Importance of the First Layer | 24 |
| Install Filament | 8 | Orienting the Part for Success | 25 |
| Heat Extruder | 9 | Other Support Documentation | 25 |
| Heat Print Bed. | 9 | Replacement Parts | 26 |
| Load Filament | 9 | Troubleshooting—Frequently Asked Questions | 27 |
| Remove Z Stops | 9 | Warranty, Service, and Support | 28 |
| Work Environment | 10 | CE Declaration of Conformity | Inside Back Cover |
| Work Configuration | 10 | | |
| Workstation Requirements | 10 | | |
| Space Clearance | 10 | | |
| Source Files (.stl and .obj) | 11 | | |
| Typical Workflow | 11 | | |
| Preparing Files for Use | 12 | | |
| Converting 3D model to .stl | 12 | | |
| Converting .stl to .gcode | 12 | | |
| Printing Materials | 13 | | |
| Vendors and Manufacturers | 13 | | |
| Recommended Temperatures | 13 | | |
| Storage Recommendations. | 13 | | |
| Safety Considerations | 13 | | |
| First Aid. | 13 | | |
| Operating the 3DP1000 Printer | 14 | | |
| Leveling the Bed. | 14 | | |
| Bed Temperature | 15 | | |

USER MANUAL SYMBOLS



[Link to product related video](#)



[Download a file](#)



[Link to specific product information](#)

MANUFACTURER

3D Platform
 6402 East Rockton Road
 Roscoe, IL 61073
 779-771-9296

Safety

SAFETY FEATURES

The 3DP1000 is designed to comply with CE standards. Standard printers, sold after 12/4/15 are equipped with the following safety features:

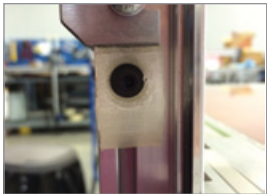

1. Pinch point protection on the Z axis

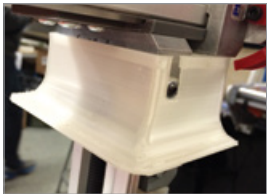

2. Pinch point protection during homing routines



3. Y axis bumper protects the user from contact with the motor end of the actuator during printing

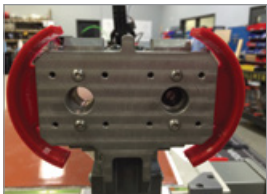

4. Y axis bumper protects the user from contact with the idle end of the actuator during printing

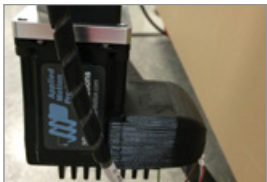

5. Wire covers prevent accidental disconnection of the motors



5. (2) Emergency Stop buttons located on the front and back of the machine

FIRST AID

- All operators should have access to first aid equipment and know how to use it.

SAFETY GUIDELINES & WARNINGS

The following safety guidelines, as well as the instructions within this user manual, ensure the safety of the user while operating and maintaining the 3DP1000 printer. If the printer is not operated as specified, the operator's safety may be compromised.

Installation

- Connect the printer to the safety-certified power cord supplied with the machine. The electrical outlet should be near the printer and easily accessible.
- Never connect the printer to an outlet that does not have a ground wire. Disconnecting the ground wire may result in electric shock.

Operation







- The 3DP1000 printer generates high temperatures in the print nozzle and the print bed—do not touch when hot. Allow the unit to cool before touching.
- Do not set objects on the heated print bed. Do not lean or stand on the print bed. Doing so may cause injury to the operator.
- Due to high temperature outputs and moving parts, the location where the printer is operating should be equipped with working smoke and flame detection.
- The 3DP1000 printer melts material during printing. Some materials may require ventilation.
- Do not leave the 3DP1000 printer unattended while in operation.
- The 3DP1000 includes linear actuators that move in multiple directions at variant speeds. When in motion, they may cause injury. Keep all items and persons clear of the moving actuators, and avoid all bumping or pinching of moving actuators.
- Do not place head or any other body part near the print head or nozzle, as injury may occur if pinched between the print bed and the nozzle.
- In case of emergency, unplug the unit from the electrical outlet—or use the Emergency Stop.

Maintenance

- All maintenance shall be performed according to the manufacturers guidelines and instructions. Failure to follow the guidelines may cause injury.
- When maintaining equipment that is hot, wear gloves to avoid injury.

Safety and Warning Symbols

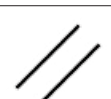
SAFETY AND WARNING SYMBOLS

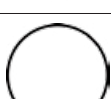
| Warning Symbol | Meaning | Location | Comments |
|---|----------------------------|---|---|
|  | WARNING HOT SURFACE | <ul style="list-style-type: none"> Print nozzle Print bed | A hot surface is located in the vicinity—do not touch. |
|  | CRUSHING OF HANDS | <ul style="list-style-type: none"> X axis Y axis Z axis | When in motion, the 3DP1000's linear actuators that move in multiple directions at variant speeds may be a pinch hazard and cause injury. |
|  | AUTOMATIC START-UP | <ul style="list-style-type: none"> Front of the print bed | The 3DP1000's linear actuators start and stop automatically depending on the printing operation. |
|  | ELECTRICAL HAZARD | <ul style="list-style-type: none"> Electrical box Digital temperature controller | Use caution when working with electricity. |
|  | EMERGENCY STOP | <ul style="list-style-type: none"> Front corner of machine Back corner of machine | In case of emergency, use the Emergency Stop buttons on the machine to turn off power. On restart, the Emergency Stop must be disengaged—twist and pull to disengage. Then, press the Reset button prior to restarting the machine. |
|  | RESET | <ul style="list-style-type: none"> Front panel of electrical box | The reset button is used prior to restarting the machine after an Emergency Stop. |
|  | ON | <ul style="list-style-type: none"> Front panel of electrical box | Turns the machine on. |
|  | OFF | <ul style="list-style-type: none"> Front panel of electrical box | Turns the machine off. |

INTENDED USE

Each 3DP1000 3D printer is inspected and calibrated, prior to shipment, to ensure proper functionality.

- This printer is intended for professional use by an operator with the ability to read instructions, having basic/low level knowledge of electronics, mechanics, and computers in general.
- Intended for printing 3D objects with materials manufactured for the FFF—fused filament fabrication—type of 3D printing.
- To be operated with the appropriate size/diameter filament as specified within this manual.
- To be operated under normal operating conditions as specified within this manual.
- Not intended to be used by children or persons not familiar with the operating and safety instructions. Use by unqualified persons may be dangerous to the user and/or damaging to the printer. Printer damage due to mis-use is not covered by the warranty.
- Any modifications to the 3D printer are at your own risk and will void the warranty. The manufacturer cannot be held responsible for modifications made by other persons.

Technical Specifications

Printer Type: FFF – Fused Filament Fabrication is a form of additive manufacturing, commonly used for 3D modeling, rapid prototyping, and production applications.

Build Area: 1 meter x 1 meter x 0.5 meter
(39.3" x 39.3" x 19.6")

Layer Resolution: Down to 70 microns (0.0027")

Note: Accuracy is dependent upon nozzle size, slice settings, geometry, print speed, filament quality, and a range of other factors. Under average conditions, it is typical to achieve layer resolutions of 100 microns with a 0.4 mm nozzle and a well-tuned and calibrated printer configuration.

Filament Diameter: 3 mm (actual diameter may vary)
For printers sold after 12-4-15, standard extruder model will accept 3 mm or 1.75 mm filament.

Nozzle Diameter: Standard Nozzle: 0.6 mm
Other nozzle sizes available from manufacturer.

Note: See important safety guidelines located in the maintenance section of this manual before changing nozzles.

Connectivity to Laptop: USB

CONTROLS & FIRMWARE

Standard with the 3DP1000 printer:

- Taurino (AT mega 2560)
- RAMPS 1.4
- Pololu Extruder Stepper Drivers
- Consult factory for Marlin Firmware source code and/or updates

PHYSICAL DIMENSIONS & WEIGHT

Overall Width: 1.422 meters (56")

Overall Depth: 1.676 meters (66")

Overall Height: 1.524 meters (60")

Approx. System Weight: 400 lbs.

Shipping Crate Dimensions:

1.524 m x 1.828 m (5 ft x 6 ft)

Approx. Shipping Weight: 1200 lbs.
(includes crate)

TEMPERATURES

Maximum Nozzle Temperature: 290°C

Maximum Print Bed Temperature: 120°C

MECHANICAL

Build Platform: Borosilicate glass, 5 mm thick

XYZ Axes: Lead screw driven SIMO® Series linear actuators from PBC Linear®. Screw max values: 640 RPM, 16000 mm/min, 267 mm/sec.

Stepper Motors: NEMA 23 stepper motors with integrated amplifier and 800 micro-stepping (as set at factory). M/S option up to 25000 available.

Upgrade to Motors with SurePrint™ Servo Technology (Optional):

- 85% more motor torque equals faster prints
- Closed loop system improves print quality
- Sophisticated control similar to a car's traction control and anti-lock brake system

ELECTRICAL

Standard AC Input:

220-250V_{RMS} Print Bed and Printer Control
15A_{RMS}

60Hz or 50Hz

Sold with (1) NEMA L6-15 plug, see typical outlet diagram below.

Printers sold prior to 12-4-15:

Single Extruder: 120V_{RMS} Print Bed, 120V_{RMS} Printer Control, 15A_{RMS}, 60Hz or 50Hz, sold with (2) NEMA 5-15 plugs, see typical outlet diagram below.

Dual Extruder: 220-250V_{RMS} Print Bed, 120V_{RMS} Printer Control, 15A_{RMS}, 60Hz or 50Hz, sold with (1) NEMA L6-15 plug for print bed and (1) 5-15 plug for printer control, see outlet diagrams below.

Outlet Diagrams

NEMA L6-15

NEMA 5-15

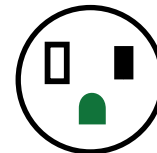

Image Credit: 'NEMA simplified pins' by Orion Lawlor - Own work. Licensed under CC BY-SA 3.0 via Wikimedia Commons - http://commons.wikimedia.org/wiki/File:NEMA_simplified_pins.svg#/media/File:NEMA_simplified_pins.svg

Shipping Crate Contents & Unpacking

CRATE CONTENTS

- 3DP1000 Printer with LCD Screen
- Filament Guide and Spool Holder
- 3DP1000 User Manual
- 1 Spool of PLA Filament (single extruder model),
2 Spools of PLA Filament (dual extruder model)
- SD Card with Start-Up Configuration and
Calibration Files

Tools Required

- Phillips Head Screwdriver
- 3 mm Allen Wrench or Hex Key

UNPACKING THE PRINTER

- The 3DP1000 printer will arrive in an industrial strength wood crate. Please take a moment to review the unpacking procedure to ensure the safety of the unpacker, as well as the printer.
- A phillips head screw driver is required for uncrating the printer.

1. Opening the Crate

The crate is equipped with a hinged front panel.

The panel should be safely opened from the top down, with the hinged bottom – creating a ramp for the printer to be easily wheeled out of the crate.

2. Release Supports

Use a phillips head screwdriver to unscrew and remove the wood support at the front of the printer.

3. Roll out the printer

Use extreme caution. Roll the printer forward and out of the crate. Avoid contact with actuators and motors on either side of the printer. Avoid contact with wiring and the padding on the shipping supports.

Use extreme caution when moving heavy machinery, such as the 3DP1000 printer.

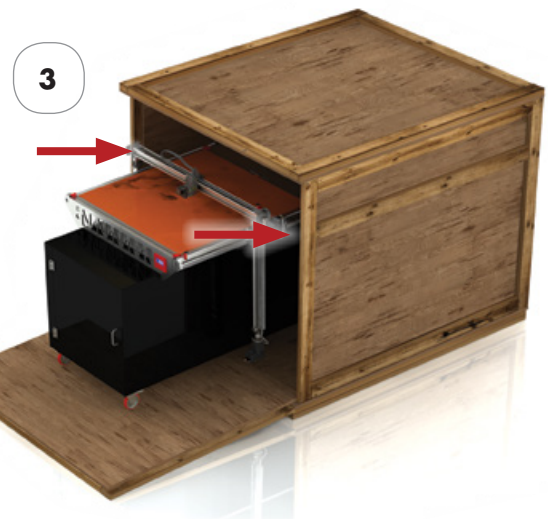
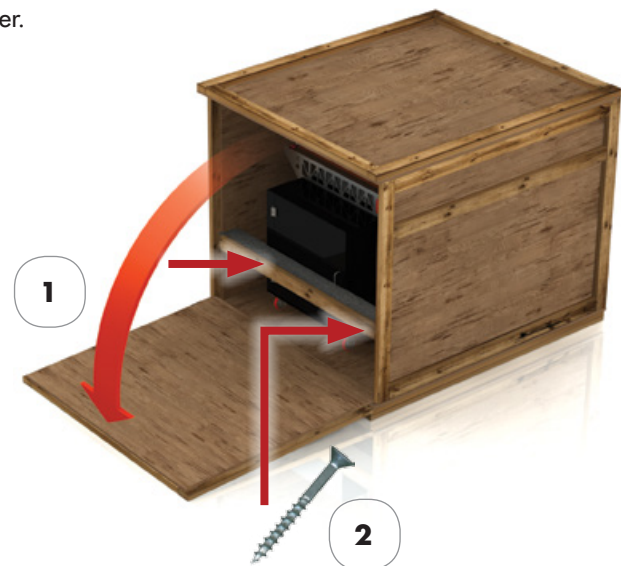

Installation of Driver and Software

INSTALL DRIVER

Any Windows computer that will be connected to the printer via USB needs the driver installed prior to connecting. Launch Taurino-DriverSetup.zip provided with the 3DP1000 printer (on the SD card) and follow the installation instructions. The Taurino Driver can also be downloaded from the website at <http://3dpunlimited.com/support/> or by clicking the link below.



[Download Taurino-DriverSetup.zip](#)

INSTALL SOFTWARE

The 3DP1000 printer from 3D Platform utilizes open source controls, allowing users to utilize the software with which they are most comfortable. 3D Platform recommends the use of Simplify3D software. The links below provide easy access to this software program, as well as the configuration files that can be imported for ease of setup. Visit the software's website for installation and usage instructions.

SIMPLIFY 3D Approximately \$140 USD

Simplify 3D software contains everything you need to begin making parts on your new 3D printer. Import and manipulate geometry, repair models, generate G-Code instructions, verify tool paths, manually control your machine, and print parts all from the same program! This is an easy-to-use and highly effective alternative to other open source programs.



www.simplify3d.com



[3DP1000-Simplify3D-Configuration.zip](#)

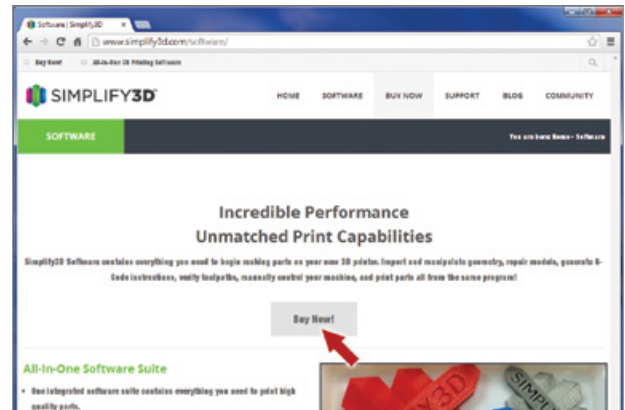

ALTERNATIVE OPEN SOURCE

Repetier Host is free, open source software used to operate your 3D printer—with controls for temperature, speed, flow, and movement. The program prepares the objects that you want to print, allows you to duplicate, rotate, scale, and arrange them on the print bed. It also includes an interface with Slic3r for easy object manipulation and quality control for printing. When downloading Repetier Host, Slic3r is downloaded automatically. Slic3r processes an .stl file (stereolithography file format), cutting the model into horizontal slices – called layers – generating tool paths to fill them and calculating the amount of material that will be extruded.

BEFORE USING THE PRINTER

Safety First! This printer is intended for professional use by an operator with at least basic knowledge of electronics, mechanics, and computers in general. Use by unqualified persons may be dangerous to the user and/or damaging to the printer. Printer damage due to mis-use is not covered by the warranty. Follow all safety guidelines within this manual.

INITIAL ACTUATOR ALIGNMENT

Prior to powering up the machine, move the X axis to the end of the build area, as shown. Gently push both sides **simultaneously** so the actuators move smoothly until they reach the end. This will eliminate any racking¹ or misalignment that occurred during shipping.

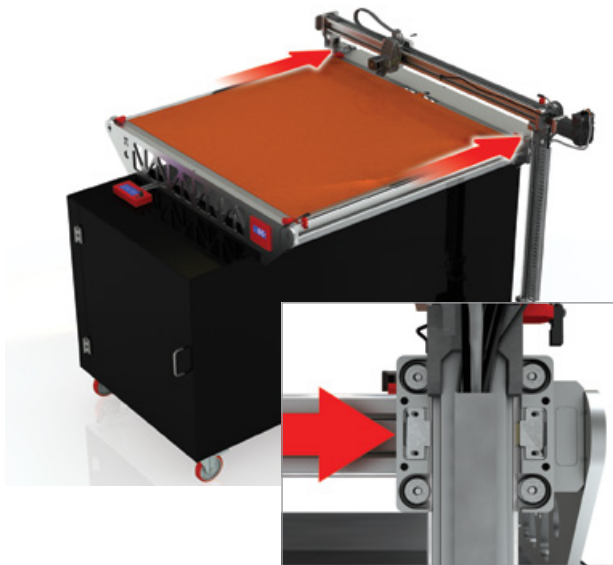

Initial alignment of the actuators must be completed prior to powering up!

¹Note: Racking of linear motion actuators can cause serious damage or breakage to mechanical hardware and/or bracketry on the 3DP1000 printer. Follow the *Initial Actuator Alignment* process to reduce the risk of racking.

Example of Racking - To Be Avoided

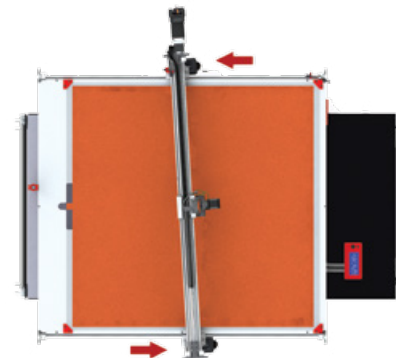

POWERING UP

Plug in the power cord for the printer and bed heater. Once the unit is plugged in, turn it on using the button located on the control panel and the front of the machine. Note: Machines sold prior to 12/4/15 have two power cords and do not have power buttons on the front of the machine.

The control panel is located inside of the enclosure toward the front of the printer.

In case of emergency, press one of the Emergency Stop buttons (located on the front and rear of the machine). For machines sold prior to 12/4/15, press the Power Off button located on the front of the electrical panel.

Standard Machine



Machines sold prior to 12-4-15

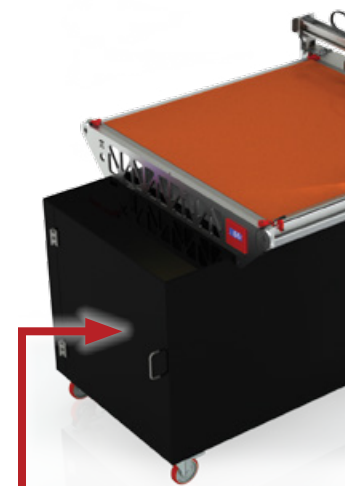

Power Located Inside Cart

 [Link to electrical wiring diagram](#)

Initial Setup

SENSOR VERIFICATION

The 3DP1000 printer has three position sensors—one for the X axis, one for the Y axis, and one for the Z axis. These sensors prevent the extruder and/or the actuators from traveling beyond the designated print area—which can cause serious damage or breakage to the extruder, glass, and/or the mechanical hardware on the printer.

Important: Each 3DP1000 is tested and calibrated prior to shipping, but it is important to verify the functionality of the sensors in case of damage or movement during the shipping process.

- Hold a piece of metal—such as a coin—under each sensor location. The red light indicates the sensor is operational.
- Contact 3D Platform if sensors are non-operational. Do not attempt to operate printer.

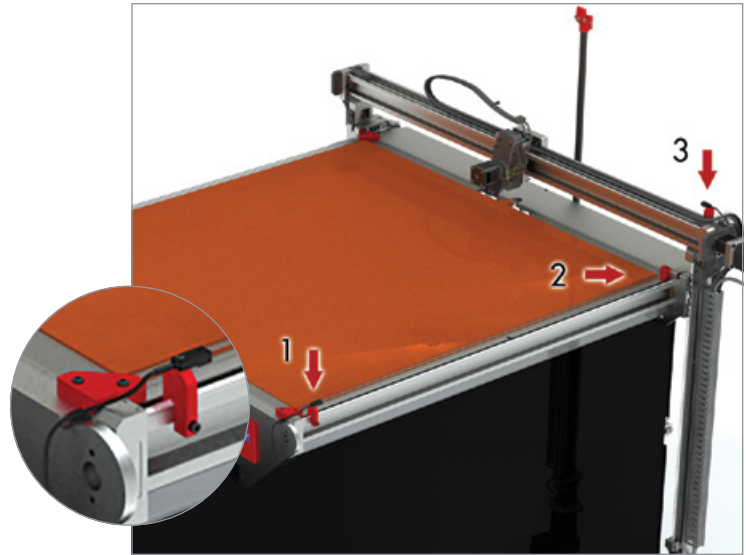

CONNECT THE USB

Locate the USB cord on the front of the printer. Plug the USB cord into your computer.

Note: It is recommended to install the driver and 3D printing software PRIOR to connecting the printer to your computer.

Launch your 3D printing software and connect to the 3DP1000. You may need to 'Refresh Ports' in order for your computer to initially find the printer.

INSTALL FILAMENT SPOOL

The filament spool holder is located on the back side of the printer. Remove the pin on the left side of the filament spool holder to release the rod.

Slide the filament roll onto the rod. Secure the filament by returning the rod to the original position and re-inserting the pin.

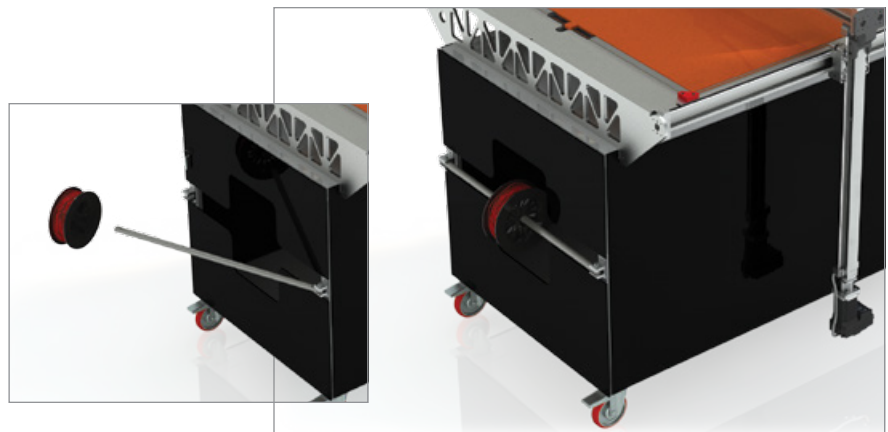

Visit www.3DPlatform.com

HEAT THE EXTRUDER

Preheat the extruder using your software and computer interface, or by using the LCD control unit.

1. Press the button on the LCD Screen, select *Prepare*, select *Preheat PLA*.

See detailed instructions for the LCD control unit on [page 16](#).

LOAD FILAMENT

Feed the filament through the filament guide loop. Press and hold the bolt on the extruder to release the hob while pressing firmly to insert the filament.

Hold the filament firmly and exert pressure until it begins to extrude from the bottom of the nozzle. Make sure the extruder is heated prior to loading filament.

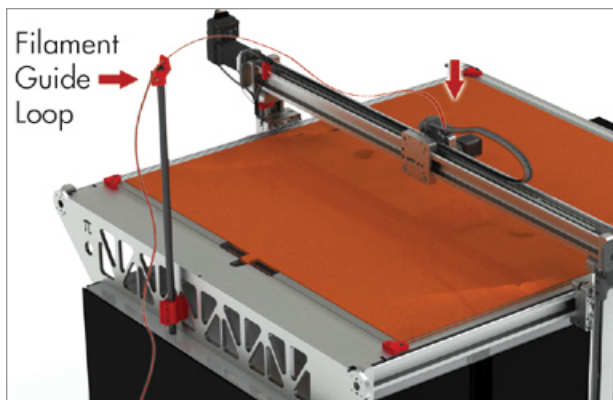

HEAT THE PRINT BED

Set the print bed heat to 70° C. This is your initial bed temperature. Additional heat may be necessary depending on what print material is used. Refer to the Recommended Temperatures table on [page 13](#).



- A. Printers purchased prior to 12-4-15 have the temperature control unit for the print bed located on the front of the machine. The print bed control operates independently.
- B. Printers purchased after 12-4-15 operate the temperature of the print bed through the LCD control unit or with 3D printing software.



Note: Turning the bed heat on in the setup process will allow time to reach optimal temperature.

REMOVE Z-STOPS

Z-Stops are used for holding the Z axis position during shipping. Remove the (two) Z-Stops prior to homing. Raise the Z axis slightly to remove the Z-Stops.

1. Press the button on the LCD Screen, select *Prepare*, select *Move Axis*, select *Move 1 mm*, select *Z Axis*, turn knob right to move Z axis up.
2. Raise the Z axis using your computer/software.

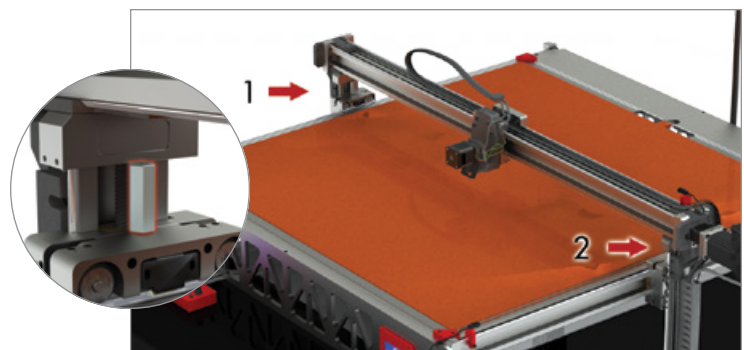

Work Environment

Extreme heat, humidity, blowing vents, and/or fans can adversely affect the print quality of the 3DP1000. The printer should be located in a controlled temperature environment with an ambient operating temperature in the range of 15° - 32°C (60° - 90°F).

WORK CONFIGURATION

The 3DP1000 is capable of carrying out the additive manufacturing process under open source controls, via 3D model output in the .gcode format. The printer can be operated using the USB computer interface or independently with the LCD control unit with SD card slot. The heated print bed is controlled independently.

Files can be processed on any workstation and .gcode delivered to the printer via SD card.

WORKSTATION REQUIREMENTS

The 3DP1000 utilizes open source controls. Computer/workstation requirements are dependent on the software choice of the operator.

SPACE CLEARANCE

The diagram illustrates the necessary clearance surrounding the 3DP1000 workstation.

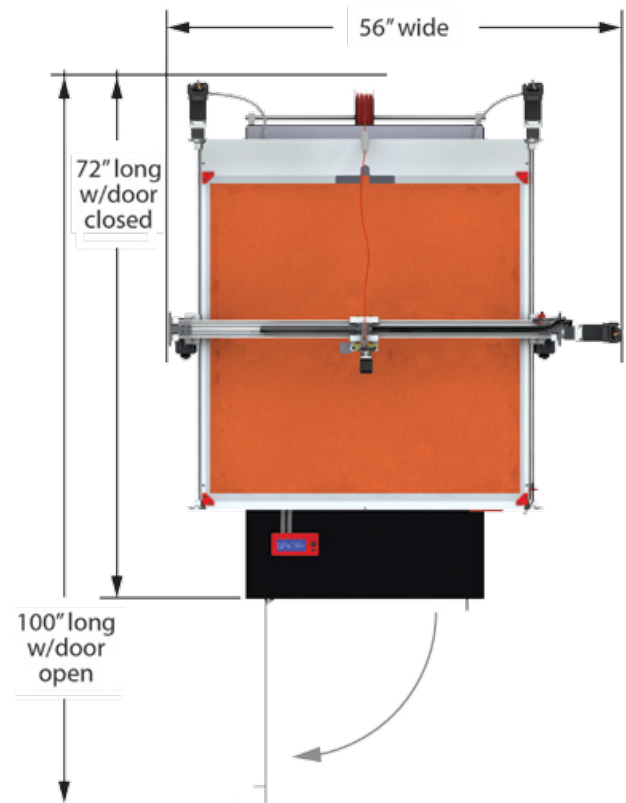

Source Files & Typical Workflow

SOURCE FILES

The 3DP1000 printer produces three dimensional objects using the FFF—Fused Filament Fabrication—type of 3D printing. **The file type that the 3DP1000 printer requires is .gcode**—which is created from 3D model.

G-code is a numerical control programming language which defines instructions on where to move, how fast to move, and through what path to move.

3D models can be custom designed in CAD programs such as [SolidWorks](#), [Auto CAD](#), or [Google SketchUp](#). CAD models are output in either **.stl** or **.obj** file format.

The **.stl** or **.obj** file is loaded into 3D printing software—see [page 6](#) for recommended software—where 3D print parameters are applied. Once print parameters are applied and the file is processed—commonly called slicing—the file is output as a **.gcode** for the printer.

Models designed for 3D printing can be found online at sites such as: [GrabCAD](#), [3D Marvels](#), [3D Via](#), [Google 3D Warehouse](#), [Turbosquid](#), and [Thingiverse](#).

TYPICAL WORK FLOW

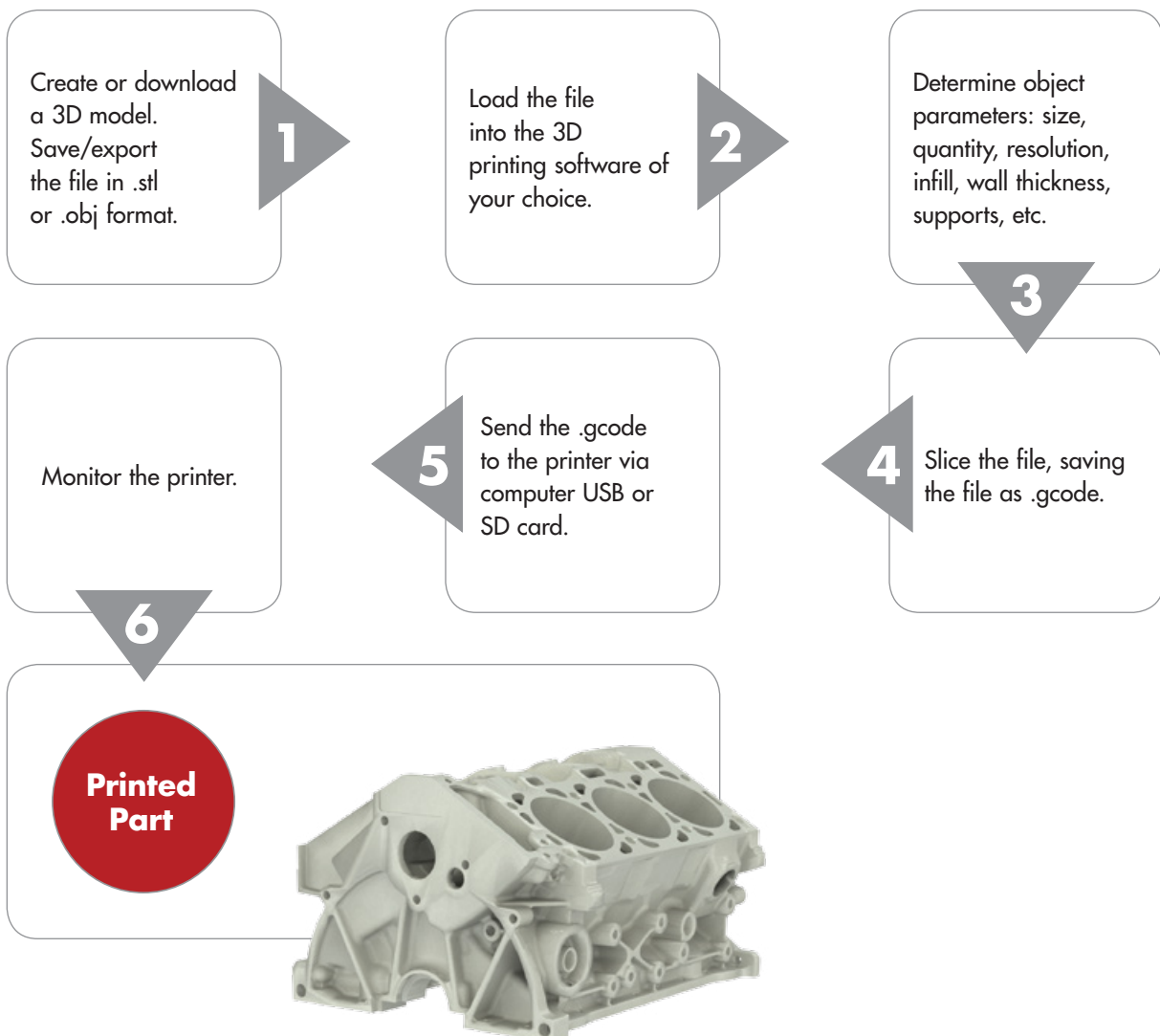

Preparing Files for Use

Before a 3D model can be printed on the 3DP1000 printer, two things must be done.

1. The CAD model must be converted to either an .stl or .obj file, and;
2. The resulting .stl or .obj file must be processed and sliced in 3D printing software and output as .gcode.



[Link to video: 1-2-3D Printing](#)

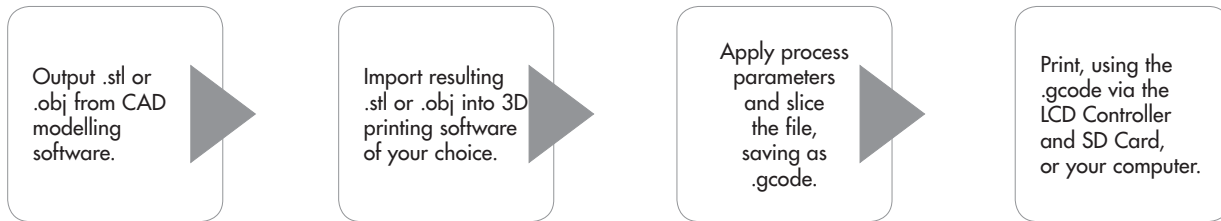

CONVERTING 3D MODELS TO .STL OR .OBJ FORMAT

This procedure is based upon the use of Solidworks, and may vary depending on the CAD software used, but generally, these guidelines apply.

1. From the File menu, select Save As or Export
2. Enter a file name
3. Under the File Type menu, select .stl or .obj
4. Select Options, set Resolution to Fine
5. Save

CONVERTING .STL OR .OBJ FORMAT TO .GCODE

This procedure is intended to provide a general process flow. Other process settings may be needed.

1. Load or Import the .stl or .obj file into your 3D printing software.
Note: You can load multiple files into the 3D printing software in order to print multiple objects in one print.
2. Arrange the object(s) on the print bed and orient appropriately for FFF 3D printing—see Orienting the Part for Success on [page 25](#) in the Printing Tips section of this manual.
3. Apply process (slice settings), including:
 - Layer height
 - Number of outside perimeters (vertical shells)
 - Number of solid top and bottom layers
 - Percentage of infill
 - Temperature
 - Speed
4. Select Prepare or Slice
5. Use the Preview by Layer function to visually inspect the object prior to printing.
6. Save, selecting File Type .gcode

3D PRINTING MATERIALS

The 3DP1000 printer uses 'open source' materials—meaning there are many different materials and manufacturers that can be used. Here are a few guidelines when choosing filament:

- The material must be 3 mm diameter—this is the filament diameter that works with 3D Platform's standard 0.6 mm nozzle, as well as other optional nozzle sizes 0.4 mm, 0.8 mm, and 1.2 mm.
- The material must have a melt point of under 290° C—this is the high end temperature of the extruder and nozzle.
- The material's recommended bed temperature must be under 120° C—this is the high end temperature of the print bed.

VENDORS & MANUFACTURERS

Material vendors that we have used include:

- <http://ultimachine.com/>
- <http://www.matterhackers.com/>
- <http://colorfabb.com/>

Online reference links:

- <http://filaments.ca/pages/temperature-guide>—this is a guide to temperatures for various materials such as PLA, ABS, NinjaFlex, Nylons, HIPS, PVA, and many more. Simply click on the link for the material you are interested in and you will see information such as temperature requirements and speed recommendations for that material.
- <http://www.matterhackers.com/3d-printer-filament>—this is a detailed comparison of FFF filaments types.

STORAGE RECOMMENDATIONS

Store filament in a cool place. Keep temperatures below 122° F (50° C). Keep material in sealed container or bag with moisture-absorbing desiccant.

 [Link to Video: What Materials Can Print on a 3DP1000](#)

RECOMMENDED TEMPERATURES

| Material | Recommended | |
|------------|---------------|------------|
| | Extruder Temp | Bed Temp |
| PLA | 195-210° C | 70° C |
| ABS | 240-250° C | 115° C |
| Ninja Flex | 220-230° C | 40-50° C |
| Nylon | 230-265° C | 115° C |
| PC | +250° C | 125-130° C |
| HIPS | 230° C | 80° C |
| PVA | 200° C | 85° C |

Note: The temperatures shown above are intended to provide a starting point when initially using different materials. Fine tuning and temperature adjustments should be expected. Also, see filament manufacturer recommended temperatures.

SAFETY CONSIDERATIONS

Avoid contact with skin and eyes. Avoid dust formation. Users should be protected from the possibility of contact with molten material during the printing process. Use personal protective equipment when working with heated materials and surfaces.

FIRST AID

Eye contact: Rinse with water, also under the eyelids, for at least 15 minutes. Call a physician immediately.

Skin contact: Rinse with water for at least 15 minutes. If skin irritation persists, call a physician. Cool skin rapidly with cold water after contact with hot polymer.

Inhalation: Move to fresh air. Call a physician.

Ingestion: Drink water as a precaution. Never give anything by mouth to an unconscious person. Do not induce vomiting without medical advice. Call a physician.

Notes to physician: Treat symptomatically.

Operating the 3DP1000

LEVELING THE PRINT BED

Why is Leveling Important? A level print bed is critical to overall print quality—especially for consistent first-layer adhesion.

- If one section of the print bed is lower than another, the first layer might not adhere properly.
- If one section of the print bed is higher than another, the glass might block the filament from flowing freely from the nozzle. This may cause damage to the glass and/or the extruder.

Tools Required

- Metric Allen Wrench or Hex Key Set



[Download Bed-level-test.stl](#)



[Link to Video: How to Level the Build Area](#)

How to Level the Print bed

1. Use the recommended print settings found on [page 21](#) and the provided file to process, slice, export gcode, and print the provided file: Bed-level-test.stl.

Monitor the print. As the filament is printed, raise or lower each section of the print bed where the filament bead is not consistent, until a consistent bead is produced.

2. There are eight (8) locations for leveling the bed, each with a Socket Head Screw for raising and lowering the print bed, and a Button Head Screw for locking the position.
 - a. Loosen the Button Head Screw (but do not remove).
 - b. Turn the Socket Head Screw clockwise to raise the print bed, counter-clockwise to lower the bed.
 - c. Tighten the Button Head Screw to lock the leveled position of the bed.

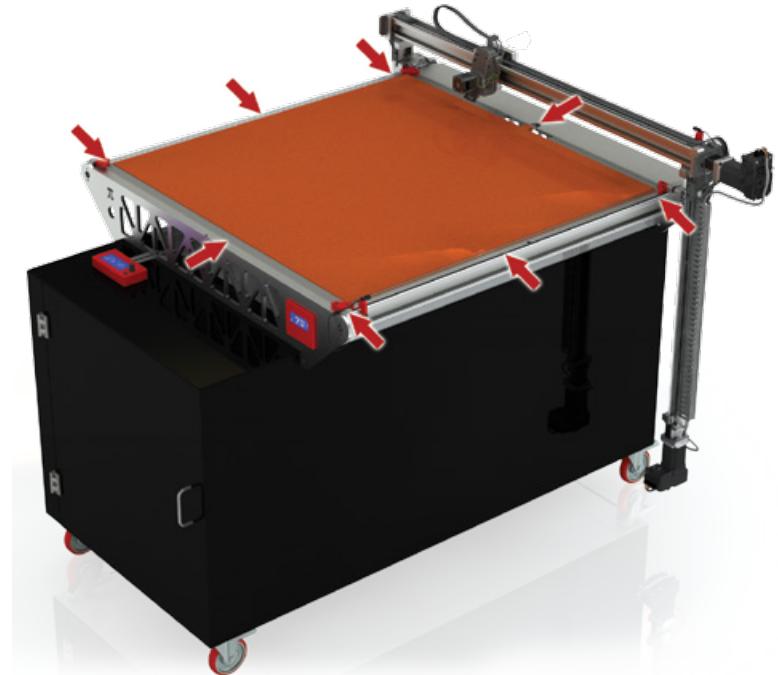

[Link to Article: The Importance of a Level Print Bed on a 3D Printer](#)

Socket Head Screw
for raising and lowering the print bed.

Button Head Screw
for locking the print bed into a set position.

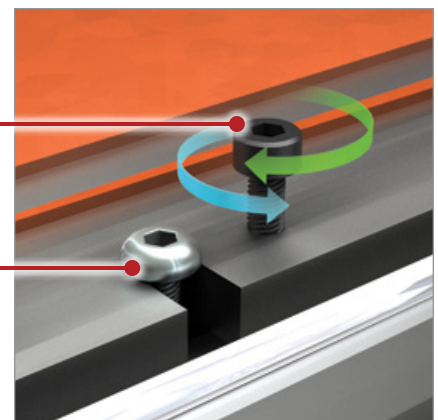

Operating the 3DP1000

HEAT THE PRINT BED

The print bed on the 3DP1000 printer is heated to provide better adhesion of your printed parts. Each material you use will likely require a different bed temperature.

- For easy removal of large or small parts, simply turn your bed temperature down to 20° C. You will hear the plastic loosening and the part will pop off the print bed.
- Printers purchased prior to 12-4-15 have the temperature control unit for the print bed located on the front of the machine. The print bed control operates independently.
- Printers purchased after 12-4-15 operate the temperature of the print bed through the LCD control unit or with 3D printing software.

Visit www.3DPlatform.com/support for detailed specifications and user instructions for the bed heater control panel.

See the *Recommended Temperature* table on [page 13](#).



[Link to bed heater control panel user instructions](#)



[Download BedTempControl-ed330.pdf](#)

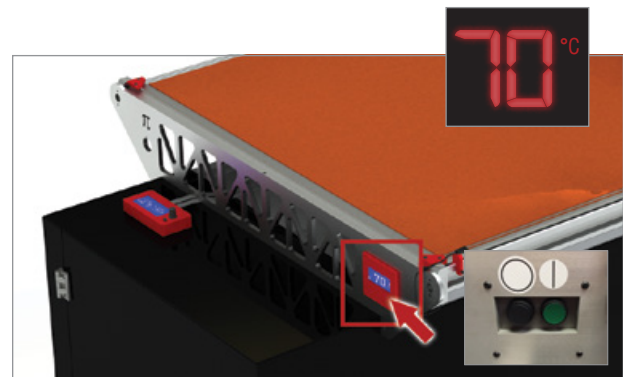

Machines sold after 12-4-15 utilize the software and/or the LCD Control Unit to heat the print bed.

Operating the 3DP1000

LCD CONTROL UNIT OPERATION

The 3DP1000 can be operated independently using the LCD Control Unit, located on the front of the machine.

There are three main functions of the LCD Control Unit:

1. Prepare the printer for printing
2. Manual control—both prior-to and during printing
3. Starting a print from the SD card

Use the button/knob combination to select and scroll through the screen options.

| | |
|---------------------|---|
| Info Screen | Displays printer information |
| Prepare | Opens Prepare menu |
| Main | Returns to Main menu |
| Disable steppers | Disable steppers until next move |
| Auto home | Homes the machine to x0, y0, z0 |
| Set home offsets | Selecting this while in any position, other than the origin, will make the machine consider the true origin to be that point in space. Exception: z will remain 0 and will instead baby-step the z offset |
| Preheat PLA | Preheats the extruder for PLA |
| Preheat ABS | Preheats the extruder for ABS |
| Cooldown | Turns off the extruder |
| Switch power off/on | Powers off/on |
| Move Axis | Opens Move Axis menu |
| Move 10 mm | Opens Move Axis 10 mm menu |
| Move Axis | Returns to Move Axis |
| Move x | Moves x axis in increments of 10 mm |
| Move y | Moves y axis in increments of 10 mm |
| Move z | Moves z axis in increments of 10 mm |
| Move extruder (2) | Moves extruder in increments of 10 mm |
| Move 1 mm | Opens Move Axis 1 mm menu |
| Move Axis | Returns to Move Axis |
| Move x | Moves x axis in increments of 1 mm |
| Move y | Moves y axis in increments of 1 mm |
| Move z | Moves z axis in increments of 1 mm |
| Move extruder (2) | Moves extruder in increments of 1 mm |
| Move 0.1 mm | Opens Move Axis 0.1 mm menu |
| Move Axis | Returns to Move Axis |
| Move x | Moves x axis in increments of 0.1 mm |
| Move y | Moves y axis in increments of 0.1 mm |
| Move z | Moves z axis in increments of 0.1 mm |
| Move extruder (2) | Moves extruder in increments of 0.1 mm |

Note: When printing, the **Prepare** menu is replaced with the **Tune** menu below.

| | |
|-----------------|---|
| Tune | |
| Main | Returns to Main Menu |
| Speed: | Speed of print—expressed in percentage |
| Nozzle: | Temperature of nozzle in °C |
| Fan Speed: | Speed of fan range from 0-255 |
| Flow: | Sets extruder factor/multiplier for all extruders—expressed in percentage |
| Flow 0/1: | Sets extruder factor/multiplier for a specified extruder—expressed in percentage |
| Layer: | Calculated current layer that the print is on |
| Babystep X CW+: | Jogs machine on the x axis .005 mm per encoder click |
| Babystep Y CW+: | Jogs machine on the y axis .005 mm per encoder click |
| Babystep Z CW+: | Jogs machine on the z axis .005 mm per encoder click |
| Change Filament | Pauses printing. Moves extruder to X and Y Home position so filament can be changed |

| | |
|-------------------------------------|--|
| Info Screen (continued) | |
| Control | Opens Control menu |
| Main | Returns to Main menu |
| Temperature | Opens Temperature menu |
| Control | Returns to Main menu |
| Nozzle: | Sets or tunes temperature of nozzle |
| Fan speed: | Sets or tunes speed of cooling fan |
| Autotemp: | If enabled, the set temperature will vary between max and min auto temp values based on the given factor and the computed target temperature = autotemp_min + factor * maximal extruder rate |
| extruder Min: | Minimum value in Autotemp |
| extruder Max: | Maximum value in Autotemp |
| extruder fact: | Factor multiplied by maximal feedrate. Used to compute dynamic temperature |
| PID-P: | Extruder Potential Coefficient |
| PID-I: | Extruder Integral Coefficient |
| PID-D: | Extruder Derivative Coefficient |
| PID-C: | Heating power = Kc*e_speed, default = 1 |
| Preheat PLA conf | Opens Preheat PLA config menu |
| Temperature | Returns to Temperature menu |
| Fan speed: | Sets the fan speed when preheating PLA |
| Nozzle: | Sets the nozzle temp when preheating PLA |
| Store memory | Stores the Preheat PLA setting changes |
| Preheat ABS conf | Opens Preheat ABS config menu |
| Temperature | Returns to Temperature menu |
| Fan speed: | Sets the fan speed for preheating ABS |
| Nozzle: | Sets the nozzle temp when preheating ABS |
| Store memory | Stores the Preheat ABS setting changes |
| Motion | Opens Motion menu |
| Control | Returns to Motion menu |
| Accel: | Absolute ceiling acceleration for all axes |
| Vxy-jerk: | Limits the change in acceleration over time for the x and y axis motors |
| Vz-jerk: | Limits the change in acceleration over time for the z axis motor |
| Vmax x: | Maximum x axis velocity |
| Vmax y: | Maximum y axis velocity |
| Vmax z: | Maximum z axis velocity |
| Vmax e: | Maximum extruder velocity |
| Vmin: | Minimum velocity |
| VTrav min: | Minimum travel velocity |
| Amax x: | Maximum x acceleration |
| Amax y: | Maximum y acceleration |
| Amax z: | Maximum z acceleration |
| Amax e: | Maximum extruder acceleration |
| A-retract: | Maximum retract acceleration |
| Xsteps/mm: | Number of steps required for the stepper motor to move 1 mm in the x direction |
| Ysteps/mm: | Number of steps required for the stepper motor to move 1 mm in the y direction |
| Zsteps/mm: | Number of steps required for the stepper motor to move 1 mm in the z direction |
| Esteps/mm: | Number of steps required for the extruder stepper motor to move filament 1 mm |
| T1X Offset: | Sets the second extruder's x axis offset from the first one |
| T1Y Offset: | Sets the second extruder's y axis offset from the first one |
| Store memory | Stores all changes to the non-volatile EEPROM memory |
| Load memory | Reads and uses all settings stored in the EEPROM memory |
| Restore failsafe | Restores all the default EEPROM data |
| Print from SD | Opens the .gcode files from SD card |
| Main | Returns to the Main Menu |
| (List of .gcode files from SD card) | |
| Resume SD from Z | Opens the .gcode files from SD card and sets the current Z height as the layer to resume printing |
| Main | Returns to the Main Menu |
| (List of .gcode files from SD card) | |

Operating the 3DP1000

LOADING FILAMENT

Feed the filament through the filament guide loop, press and hold the button on the extruder to release the hob while pressing firmly to insert the filament.

Hold the filament firmly and exert pressure until it begins to extrude from the bottom of the nozzle. Make sure the extruder is heated prior to loading filament.

Tip: Straighten the filament and cut at an angle prior to inserting into the extruder to help with ease of loading.

CHANGING FILAMENT

Filament can be changed at any time—when the printer is idle or mid-print.

- The extruder must be heated to 180° C (minimum) to remove or add filament.
- When printer is idle (not printing): raise the Z axis so the nozzle is away from the glass. Press and hold the button on the extruder to release the hob while manually pulling out existing filament, then follow the Loading Filament instructions above.
- When the printer is mid-print: press the main button on the LCD Control Unit, select Tune, select Change Filament. This manually puts the printer into Change Filament mode. Then follow the Loading Filament instructions above.
- An alarm sounds until the filament is replaced and the center button on the LCD Control Unit is pressed to resume the print.

FILAMENT SENSOR

The 3DP1000 is equipped with dual filament sensors located on top of the extruder. This feature provides security during long prints. When the filament runs out, the sensors put the printer into Change Filament mode. The X axis and Y axis are moved to the Home position and any remaining filament is reversed out of the nozzle. An alarm sounds until the filament is replaced and the center button on the LCD Control Unit is pressed to resume the print.

Note: printers sold prior to 12/4/15 may have only one filament sensor located on the front extruder.

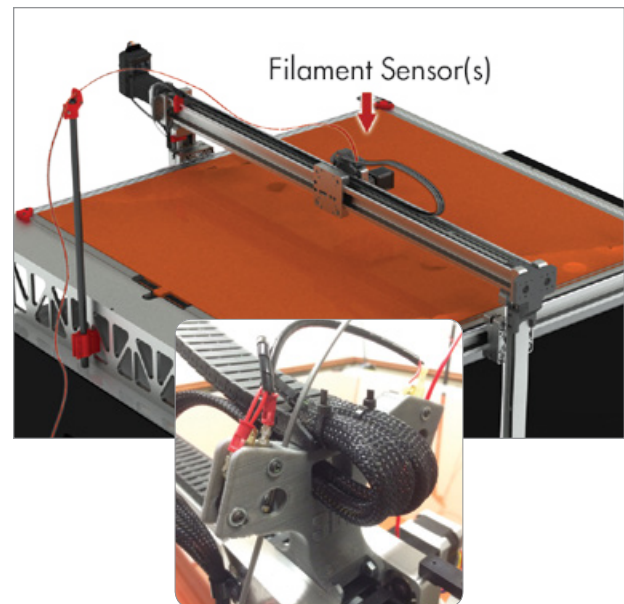

PRINTING VIA SD CARD

The 3DP1000 can be operated independently with the LCD Control Unit and an SD Card. Select Print from SD on the LCD Control Unit, then choose the .gcode file you wish to print.

PRINTING VIA USB CONNECTION WITH COMPUTER

The 3DP1000 can be operated through the 3D printing software's Manual or Machine Control Panel. Follow the Connect the USB instructions on [page 8](#). Once connected, the printer can be operated via the computer and software interface.

Care and Maintenance

MAINTENANCE

For the safety of the user and to avoid shock or unintended motion, all maintenance of the 3DP1000 3D printer should be:

- Conducted with the machine unplugged from all electrical outlets.
- Conducted when the machine is cool.

Exception: maintenance and replacement of the extruder nozzles must be done when the extruder is heated. Use extreme caution when maintaining or operating heated machinery. See details—Cleaning the Nozzle and Changing the Nozzle—on [page 19](#).

SIMO® Series actuators from PBC Linear®:

- Rail and bearing system is inclusive of internal lubrication system—requiring no preventative maintenance—for the lifetime of the machine.
- Teflon coated screw, with engineered polymer nut is designed for lifetime operation under normal operating conditions—see Work Environment on [page 10](#).
- Cam Roller carriages include built-in micro-polymer lubricators. If lubricators become damaged, contact manufacturer for replacement.

PREPARE THE PRINT BED

Prepare the build area for printing. In order for your prints to adhere to the borosilicate glass—it needs to be clear of debris but somewhat tacky. We have found that using a sugary substance, such as beer, works quite well. Pour a liberal amount onto the build area and wipe as if you were cleaning with glass cleaner. Cover the entire area that your print will touch. Repeat this process between prints to remove filament particles and other debris, as well as prepare the bed for the next print.

This is not the only method available. Other suggestions include: painter's tape, glue stick, and hairspray.

Do not use glass cleaner or alcohol on the glass. Doing so will make adhesion very difficult.



[Link to article: Perfecting the First Layer](#)

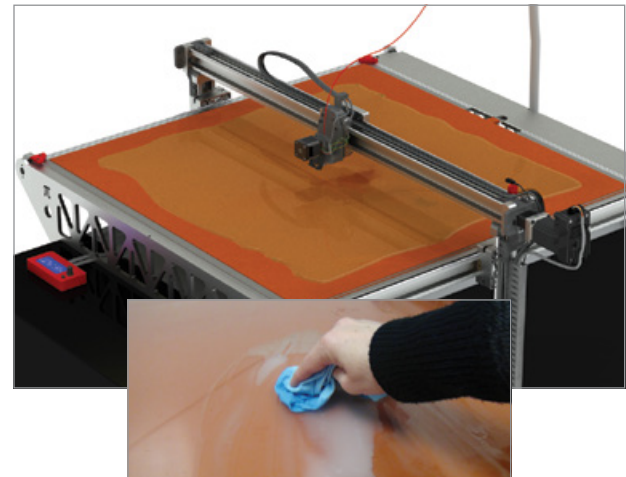

CLEARING THE HOB

For machines sold prior to 12/4/15, this process can be used to clear the hob mechanism. It is best practice to use a metal pick to clean the grooves in the feeding mechanism in the extruder—called the hob. In time—especially long prints—filament particles may fill the gripping crevices in the hob and create filament feeding issues.

Tip: If your filament is not feeding smoothly, try clearing the hob.



For the safety of the user, use extreme caution when working with heated machinery.

Care and Maintenance

CLEANING THE NOZZLE

Use extreme caution when maintaining or operating heated machinery. The nozzle must be heated to 180° C (minimum) when cleaning.

When to clean the nozzle:

- When filament is not flowing smoothly
- When filament is not being extruded appropriately
- When changing material type
- Periodically between large prints—preventative maintenance

How to clean the nozzle:

- Canola oil treatment:
 - Dip ¾" of filament into oil and shake off excess
 - Heat nozzle to 250-260° C
 - Push filament through the extruder and nozzle by hand
 - Extrude 200 mm of filament
 - Repeat 3-4 times



Safety Guidelines

- Wear heat resistant gloves
- Prior to all routine maintenance on the extruder and/or nozzle, insert 6 inch tall block under actuator to avoid any type of crush hazard
 - Use appropriate tools for all cleaning and maintenance.

| NOZZLE SIZE | ID DOTS |
|-------------|---------|
| 0.25 mm | 0 |
| 0.30 mm | 1 |
| 0.35 mm | 2 |
| 0.40 mm | 3 |
| 0.60 mm | 4 |
| 0.80 mm | 5 |

Tools Required

- 7 mm Wrench or Socket Wrench
- Crescent Wrench

CHANGING THE NOZZLE



Do not touch heated nozzle.

1. To replace the nozzle on the extruder head, first send the extruder to the home location.
2. Once the extruder is at the home position, raise the z axis by 220 mm. This will give room to work under the extruder head.
3. Set the extruder nozzle temperature to 200° C. This will melt any plastic inside the extruder and loosen the nozzle.
4. Once the temperature has reached 200° C, use a crescent wrench and 7 mm wrench to remove the nozzle. Use the crescent wrench to hold the base steady. Use caution—nozzle is hot!
5. Once nozzle is removed select the replacement nozzle. Nozzle size can be determined by inspecting the machined dots along the side of the nozzle. Refer to the table below for sizes.
6. Once new nozzle has been selected, hand thread it into the extruder.
7. Then use the wrench and crescent wrench to tighten the nozzle into the assembly, only tighten until snug. **DO NOT OVER TIGHTEN.**
8. Once nozzle is tightened, set the extruder temperature from 200° C to 280° C. This will heat up the nozzle and ensure it has a tight fit. Make sure the extruder fan is turned off or the extruder will not reach the desired temperature.
9. Once the temperature has reached 280° C, use the wrench and crescent wrench to tighten the nozzle so it is snug.

Care and Maintenance

WIRING DIAGRAM

For the safety of the user and to avoid shock or unintended motion, all electrical maintenance of the 3DP1000 3D printer should be:

- Conducted with the machine unplugged from all electrical outlets.
- Conducted when the machine is cool.
- Conducted by a trained electrician



[Link to electrical wiring diagram](#)























3DP PLATFORM 3D PRINTER ROSCOE, IL ELECTRICAL SCHEMATICS

| SHEET | DESCRIPTION |
|-------|-------------------|
| 1 | TABLE OF CONTENTS |
| 2 | 220VAC SCHEMATICS |
| 3 | SPARE SHEET |
| 4 | 48VDC SCHEMATICS |
| 5 | SPARE SHEET |
| 6 | 24VDC SCHEMATICS |
| 7 | SPARE SHEET |
| 8 | RAMPS BOARD |
| 9 | CABLE DRAWINGS |

Calibration & Test Prints

- The files listed below are supplied with the printer, on an SD card, in order to assist in the set up and calibration process.
- Verify your print bed is level using the bed leveling file supplied (Bed-level-test.stl)—make adjustments the file prints.

SUPPLIED FILES

| | | | |
|---|----------------------|----------------|-----------|
|  .6mmServo40mmCubeFront.fff | 12/3/2015 2:26 PM | FFF File | 14 KB |
|  .6mmServo40mmCubeRear.fff | 12/3/2015 2:53 PM | FFF File | 14 KB |
|  .6mmServo40mmSolidBox.fff | 12/4/2015 9:28 AM | FFF File | 14 KB |
|  .6mmServoStackedExt1.fff | 12/3/2015 3:52 PM | FFF File | 14 KB |
|  .6mmServoStackedExt2.fff | 12/3/2015 3:53 PM | FFF File | 14 KB |
|  40mmSolidBox | 12/4/2015 9:32 AM | 3D Model Files | 4 KB |
|  40mmSolidBox | 12/4/2015 9:33 AM | 3D Model Files | 202 KB |
|  Calibration1-40mm-cubeFront | 12/3/2015 2:25 PM | 3D Model Files | 4 KB |
|  Calibration1-40mm-cubeFront | 12/3/2015 2:25 PM | 3D Model Files | 41 KB |
|  Calibration1-40mm-cubeRear | 12/3/2015 2:54 PM | 3D Model Files | 4 KB |
|  Calibration1-40mm-cubeRear | 12/3/2015 2:55 PM | 3D Model Files | 39 KB |
|  cycloidal_vase | 12/4/2015 10:26 A... | 3D Model Files | 2,959 KB |
|  cycloidal_vase | 12/4/2015 10:26 A... | 3D Model Files | 10,433 KB |
|  cycloidal_vase | 7/22/2015 3:56 PM | 3D Model Files | 6,406 KB |
|  StackedThinWallBoxDual | 12/3/2015 3:52 PM | 3D Model Files | 7 KB |
|  StackedThinWallBoxDual | 12/3/2015 3:51 PM | 3D Model Files | 29 KB |
|  stackedthinwallbox-extruder-1 | 12/3/2014 1:16 PM | 3D Model Files | 1 KB |
|  stackedthinwallbox-extruder-2 | 12/3/2014 1:16 PM | 3D Model Files | 1 KB |
|  The Chip | 12/4/2015 1:15 PM | 3D Model Files | 6 KB |
|  The Chip | 12/4/2015 1:14 PM | 3D Model Files | 36 KB |
|  WidgetXX2(3) | 12/4/2015 1:18 PM | 3D Model Files | 311 KB |
|  WidgetXX2(3) | 12/4/2015 1:18 PM | 3D Model Files | 5,075 KB |



Download Files at www.3DPlatform.com

Printing Tips

MEASURE THE FILAMENT

The standard nozzle for a 3DP1000 printer is 0.6 mm which requires 3 mm filament. However, filament diameters vary depending on manufacturer. For consistent layer resolution and high print quality, two measurements are recommended.

Measure the filament diameter with a micrometer in several areas along the filament roll. Enter the actual diameter in the slicing software.

IMPORTANCE OF TEMPERATURE

Extruder Temperature

Each material you use with the 3DP1000 printer will likely require a different temperature for the extruder. Start with the temperatures provided and make adjustments as needed.

- If your extruder is not hot enough, the filament may not adhere to the print bed.
- If your extruder is not hot enough, the filament may not adhere from layer to layer.
- If your extruder is too hot, the filament may warp or you may see an unwanted variance in layer width.

Print Bed Temperature

The print bed on the 3DP1000 printer is heated to provide better adhesion of your printed parts. Each material you use will likely require a different bed temperature.

- For easy removal of large or small parts, simply turn your bed temperature down to 20° C. You will hear the plastic loosening and the part will pop off the print bed.

Tools Required

– Micrometer

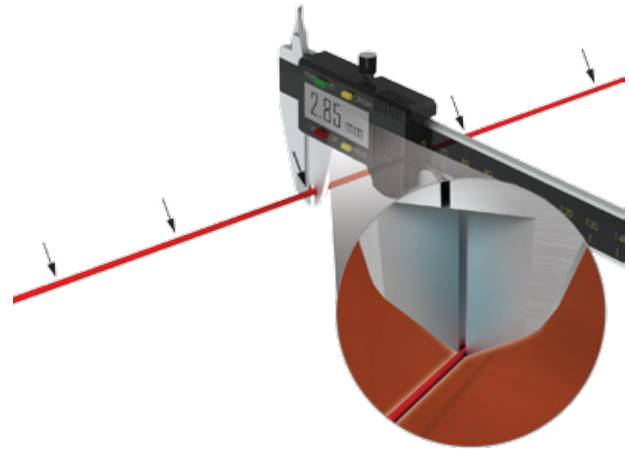

SEASONING THE NOZZLE

The canola oil treatment is used primarily as routine maintenance of the nozzles. However, this treatment should also be used prior to using a new nozzle to help prevent clogging and promote smooth filament flow.

- Canola oil treatment:
 - Dip $\frac{3}{4}$ " of filament into oil and shake off excess
 - Heat nozzle to 250-260° C
 - Push filament through the extruder and nozzle by hand
 - Extrude 200 mm of filament
 - Repeat 3-4 times

Z-GAP

What is Z-Gap? The Z-Gap is the distance your extruder is away from the glass of the print bed when it begins extruding. Each 3DP1000 printer is equipped with X, Y, and Z axis position sensors. So, the Z-Gap can be thought of as the space between the Home Z setting and the place where the extruder needs to be to lay down the first layer of filament.

In order to adjust the Z-Gap, you need to define the Z-Offset in the software prior to slicing.

- Each 3DP1000 printer is calibrated to a '0' Z-Offset at the manufacturing facility prior to shipment. However, if your first layer shows signs of the nozzle being too far or too close to the print bed—adjust the Z-Offset in the software prior to slicing.

Why are Z-Gap and Z-Offset Important?

- If the Z-Gap is too large, the extruded filament bead will not contact the glass properly, resulting in a round bead of filament. This could lead to a first layer that is not adhered to the print bed and a failed print. See example A.
- If the Z-Gap is too small, the extruded filament is pushed down creating a wider bead than intended, as well as an uneven layer height. Additionally, a Z-Gap that does not allow sufficient room for the filament to extrude can cause back pressure and problems with the extruder. See example B.

How to Enter the Z-Offset

- In Simplify3D, the Z-Offset is located in the G-Code tab of the Process Settings.
- In Repetier Host, the Z-Offset is located in the Slicer tab, select Configure, select Printer Settings tab.

 [Link to Article: The Two Things You Must Do For Successful 3D Printing](#)

 [Link to Article: The Five Most Important 3D Printing Tips You Must Know](#)

The **Z-Offset** in Slic3r compensates for the **Z-Gap** in the 3DP1000 Printer.

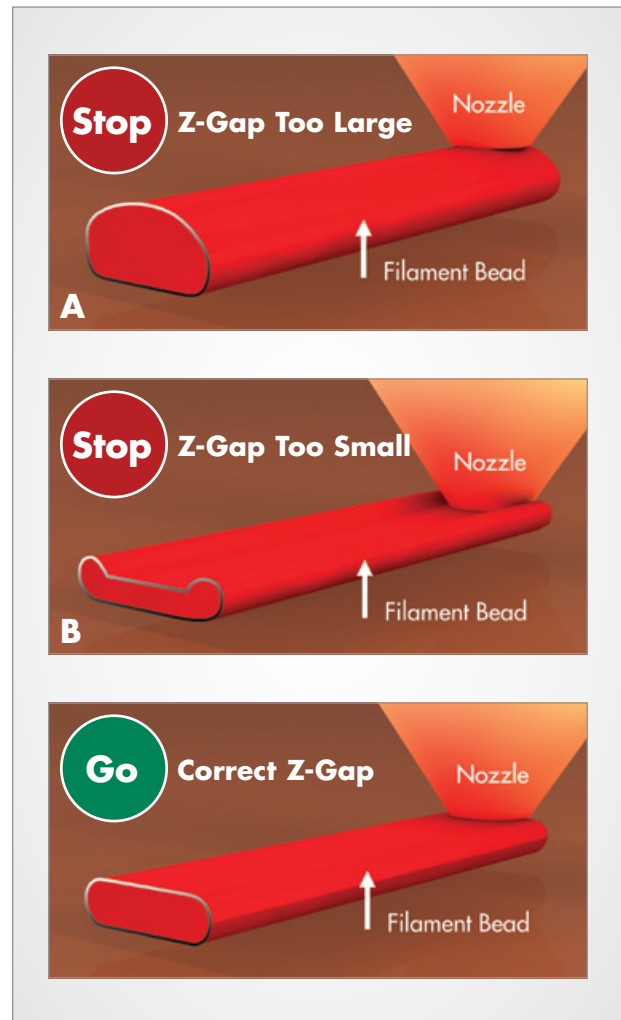

Printing Tips

GETTING A GOOD FIRST LAYER

The first layer may be the most important layer of any print—and perhaps the most difficult. A good first layer is vital to the success of your print.

Qualities of a good first layer include:

- Clean (clear of debris), prepared glass
- Proper bed temperature
- Optimal first layer nozzle height ([Z-Gap, page 23](#))

A good first layer adheres to the print bed, is the correct distance from the print bed, is visibly smooth and level, without gaps or bumps.

Here are a few tips for getting a good first layer.

- Make sure the print bed is level
- Clean—clear any debris—from the print bed and prepare the glass for printing ([Prepare the Print Bed, page 18](#))
- Getting the first layer height dialed in is critical—see graphic on the right. Reference [page 23](#).
 - If the first layer is too high and it will not stick
 - If the first layer is too low it will create a valley, and may drag the nozzle on the glass
 - The first layer height is correct when the bead of filament is flattened slightly and even
- Heat the print bed to the recommended temperature; base upon the material being used
 - If adhesion problems persist, increase bed temperature to 80-85° C
- Increase the nozzle temperature by 10-20° C for the first 1-3 layers to aid in adhesion
- Decrease the printing speed by 30% for the first layer
- Print a test print to ensure good first layer adhesion



[Link to article: Perfecting the First Layer](#)

First layer height too high



First layer height too low



First layer height correct



BABYSTEPPING

Babysteping is a function that allows the user to move—babystep—the X, Y, and Z axis during a print. This is especially useful when tweaking the first layer height.

How to babystep:

When the print starts:

1. On the LCD panel go to Tune
 2. Scroll down to Babystep Z
 - Counter Clockwise = lower the nozzle
 - Clockwise = raise the nozzle
- Tip: Do this while the skirt outlines are printing to avoid inconsistency in the actual printed piece.
3. Each click of the encoder is only 2.5 µm
 - It may be difficult to see this movement, however, it will begin to show as the nozzle extrudes
 4. Continue to babystep until the first layer is sticking and resembles the graphic shown above.



[Link to article: Stop 3D Print Warps, Curls, and Peels](#)

Printing Tips and Support Documentation

ORIENTING THE PART FOR SUCCESS

Part orientation—the direction the part is positioned on the print bed—effects the print quality, print time, surface finish, and overall print-ability of the model. The following tips are intended to assist in orienting your part for a successful print.

- Position so the most surface area is in level contact with the print bed.
- If possible, orient the part to reduce or eliminate support structures.
- Consider surface finish. Which part of the model is most important? Position the part accordingly.
- Reducing support structures will reduce print time.
- When break-away support structures are used directly on the print bed, the use of a raft may be necessary to avoid adhesion problems.



[Link to article: Rafts, Skirts, and Brims](#)

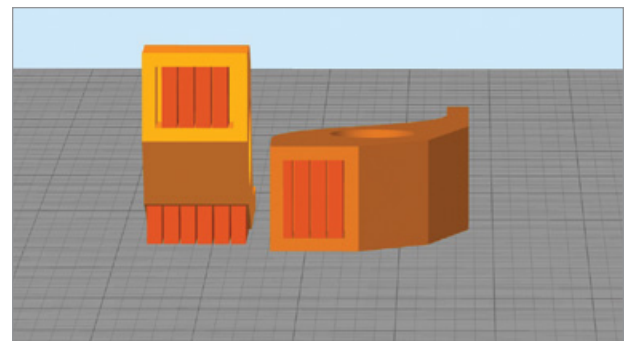
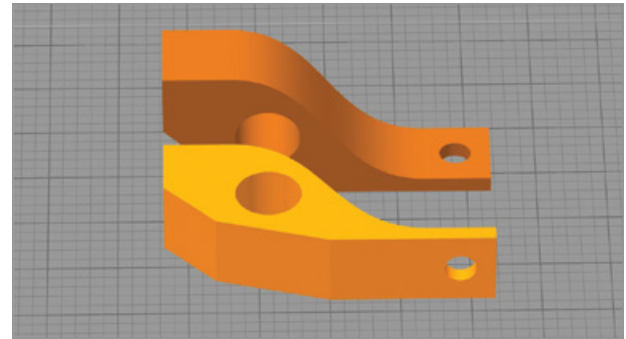

AUTODESK® 3D PART VIEWER

This online tool provides instant viewing of 2D and 3D designs—without purchasing software.

<https://360.autodesk.com/Viewer>

FINE TUNING THE 0.6 MM NOZZLE

View and download the user guide to fine tuning the standard 0.6 mm nozzle.

<http://3dpunlimited.com/support/>

SOFTWARE TUTORIALS

Please visit the following links for Slicer and Simplify 3D software tutorials. Note: these tutorials are not produced by 3D Platform, but are recommended.

- Simplify 3D
<https://www.youtube.com/watch?v=D968RL1Z6l4>
- Slicer
<https://www.youtube.com/watch?v=o1HPeovBclc>

TYPICAL SOFTWARE CONFIGURATION

Use the typical software configuration for initial setup with 3D printing software. Access information by clicking the link:

<http://3dpunlimited.com/support/>

Replacement Parts

| PART NUMBER | DESCRIPTION |
|----------------|---|
| X1000-NZZL030 | 0.3 mm Nozzle |
| X1000-NZZL035 | 0.35 mm Nozzle |
| X1000-NZZL040 | 0.4 mm Nozzle |
| X1000-NZZL060 | 0.6 mm Nozzle |
| X1000-NZZL080 | 0.8 mm Nozzle |
| tbd | 1.2 mm Nozzle |
| X1000-0008 | Fan: PLA/Material Unit |
| X1000-ASY-0002 | Extruder Assembly Complete - BULLDOG |
| X1000-0015 | Upper Glass Bracket - 3D Printed |
| X1000-0001 | 3DP Heated Pad, 1 meter x 1 meter, 1650W/110V |
| X1000-0001-220 | 3DP Heated Pad, 1 meter x 1 meter, 3000W/220V |
| X1000-ASY-0004 | LCD Control Unit with SD Card Slot, Smart LCD |
| X1000-ASY-0005 | Filament Sensor - 7779K520 |
| X1000-0059 | Thermistor, M3 STUD, E3D/REPRAP HOT END |
| X1000-0026 | Vortex Fan |

CONTACT SUPPORT

- Email your technical question and requests for replacement parts to support@3dpunlimited.com.
- Contact your sales representative with questions.
- See warranty information on [page 28](#).

FREQUENTLY ASKED QUESTIONS

Q: What is "open source" and how does it relate to the printers from 3D Platform?

A: The term, Open Source, most commonly refers to a computer program or programs in which the source code is available to the public for use and can be modified from its original design. The *3DP1000* printer from 3D Platform utilizes open source software and control platforms. This provides a cost-effective and easy-to-use interface with the printer.

Q: What type of 3D printer is the *3DP1000*?

A: The *3DP1000* utilizes FFF (Fused Filament Fabrication) printing technology—where a filament of one material (plastic, wax, metal, etc.) is deposited on top of or alongside the same (or similar) material making a joint (by heat or adhesion).

Q: What is the best print quality the *3DP1000* can do? And, what is the relationship between size, quality, and print time?

A: The printer can achieve a layer resolution as fine as 70 microns. A key consideration is the relationship between size, quality, and print time. A part that is 75 mm x 75 mm x 25 mm, with a 300 micron layer resolution, may take 3 hours to print. The same part, with a 70 micron layer resolution, may take up to 10 hours to print. Using this premise, imagine the time needed to print a part that is 1000 mm x 1000 mm x 500 mm.

Q: How big can I make my model?

A: The *3DP1000* print area is 1000 mm x 1000 mm x 500 mm.

Q: What type of file do I send to the printer? And, where can I get files to print?

A: The file type that your printer requires is .gcode – which is created from a 3D model. 3D models can be custom designed in CAD programs such as [SolidWorks](#), [Auto CAD](#), or [Google SketchUp](#). 3D models can also be found online at sites such as: [GrabCAD](#), [3D Marvels](#), [3D Via](#), [Google 3D Warehouse](#), [Turbosquid](#), and [Thingiverse](#).

Q: What materials can I use on the *3DP1000* printer?

A: The *3DP1000* printer is capable of printing any material (3 mm spools) which is created for *Fused Filament Fabrication* (FFF), including but not limited to PLA (Polylactic Acid), ABS (Acrylonitrile Butadiene Styrene), PC (Polycarbonate), Nylon, Ninja Flex, and HIPS (High Impact Polystyrene).

Q: How much power is needed to operate the *3DP1000* printer?

A: The *3DP1000* printer is available in both 110 and 220 volt. The 110 volt system provides ample power for printing materials requiring bed temperatures below 70° C. Materials requiring higher bed temperatures, require 220 volts.

Q: What is support material? How does it work with a single extruder and/or a dual extruder?

A: Support structures can be generated in your 3D printing software. They are used to hold up printed parts where the part is not supported – generally any overhang over 45° will require supports. When using a printer with a single extruder, the support material is generated and then broken away after printing. When using a machine with a dual extruder, wash away support material can be utilized.

Q: Can I use filament from any manufacturer?

A: Yes! The *3DP1000* is designed to accommodate filament from multiple manufacturers – as long as it is 3 mm in size.

Please visit our website at www.3DPlatform.com for more information.

Warranty & Service

Copyright

- ©2015 by 3D Platform™. All rights reserved. Be advised of the following terms regarding this User Manual from 3D Platform™.
- All specifications and other information within this User Manual is subject to change at any time without notice and is provided for convenience purposes only. 3D Platform reserves the right to change the information or revise this User Manual in its sole discretion at any time.
- Nothing contained in this User Manual can be reproduced without written permission from 3D Platform. Use of the www.3DPlatform.com website constitutes acceptance of its Terms of Service and Privacy Policy.

Warranty

- 3DP warrants that goods supplied pursuant to the sale order shall conform to the description therein stated and shall be free from defects in material or workmanship.
- This warranty shall be effective for a period of (90) days from the date of delivery of the goods to buyer.
- THE WARRANTY IS BASED UPON THE PRINTER BEING USED UNDER THE NORMAL CONDITIONS DESCRIBED IN THE DOCUMENTATION PROVIDED TO YOU. WARRANTY COVERS REPLACEMENT PARTS AND NOT ON-SITE SERVICE. THIS WARRANTY EXCLUDES (I) NORMAL CONSUMABLE OR EXPENDABLE PARTS (SUCH AS NOZZLES), (II) REPAIRS OR REPLACEMENTS DURING THE WARRANTY PERIOD BECAUSE OF ABNORMAL USE, MISUSE, NEGLIGENCE, OR IMPROPER OR UNAUTHORIZED SERVICE.
- 3D Platform offers [extended warranty options](#) and [on-site setup](#). Please consult website or contact 3D Platform at sales@3dpunlimited.com to explore what option is best suited for you.
- SELLER DISCLAIMS ALL OTHER WARRANTIES EXPRESSED OR IMPLIED, ORAL OR WRITTEN, INCLUDING, WITHOUT LIMITATION, THE IMPLIED WARRANTIES OF MERCHANTABILITY AND FITNESS FOR A PARTICULAR PURPOSE.

Limitation of Liability

- Seller shall not be liable to buyer for any lost profits or other economic loss of buyer, or any direct, indirect, special, consequential, incidental or other similar damages arising out of any breach of this agreement by seller.
- Any obligations of seller pursuant to this agreement or the failure of the goods to perform in any particular manner.
- In no event shall the liability and/or obligations of 3D Platform arising out of the purchase of equipment by you or others exceed the purchase price of the 3DP1000 3D printer.



www.3DPlatform.com

SERVICE & SUPPORT

| | |
|-----------|--|
| Support | <p>Visit the website for literature and video documentation to quickly answer common questions regarding your printer. www.3DPlatform.com/support</p> <p>Email your technical question. Include images of the problem if necessary. support@3dpunlimited.com</p> |
| Sales | sales@3dpunlimited.com |
| Marketing | marketing@3dpunlimited.com |

Declaration of Conformity

Company Name: 3D PLATFORM

Street Address:

P.O. Box 6980

Rockford, IL 61125

Name and address of company Authorized to compile the Technical File

ACC - Services Contact

105 route des pommiers

Centre Ubidoca

74370 St Martin Bellevue

France

3D PLATFORM declares under our sole responsibility that the equipment described as:

Equipment Name: 3D Printer

Generic Equipment Description: FFF 3D Printer

Model /Type: 3DP 1000

Serial number(s):

Complies with the requirements of the following European Directives:

- Machinery Directive 2006/42/EC
- Electromagnetic Compatibility Directive 2004/108/EC

Main standards considered:

- EN 12100-1:2003
- EN 12100-2:2003
- EN 61000-6-2:2006
- EN 61000-6-4:2007
- EN 60204-1:2006

Date: _____

At: Rockford, IL USA

Name of Signatory: _____



3D Platform™
P.O. Box 6980 | Rockford, IL | 61125
marketing@3dpunlimited.com
www.3DPlatform.com

Authorized Representative