

# PDP Series

Positive displacement  
dosing pump

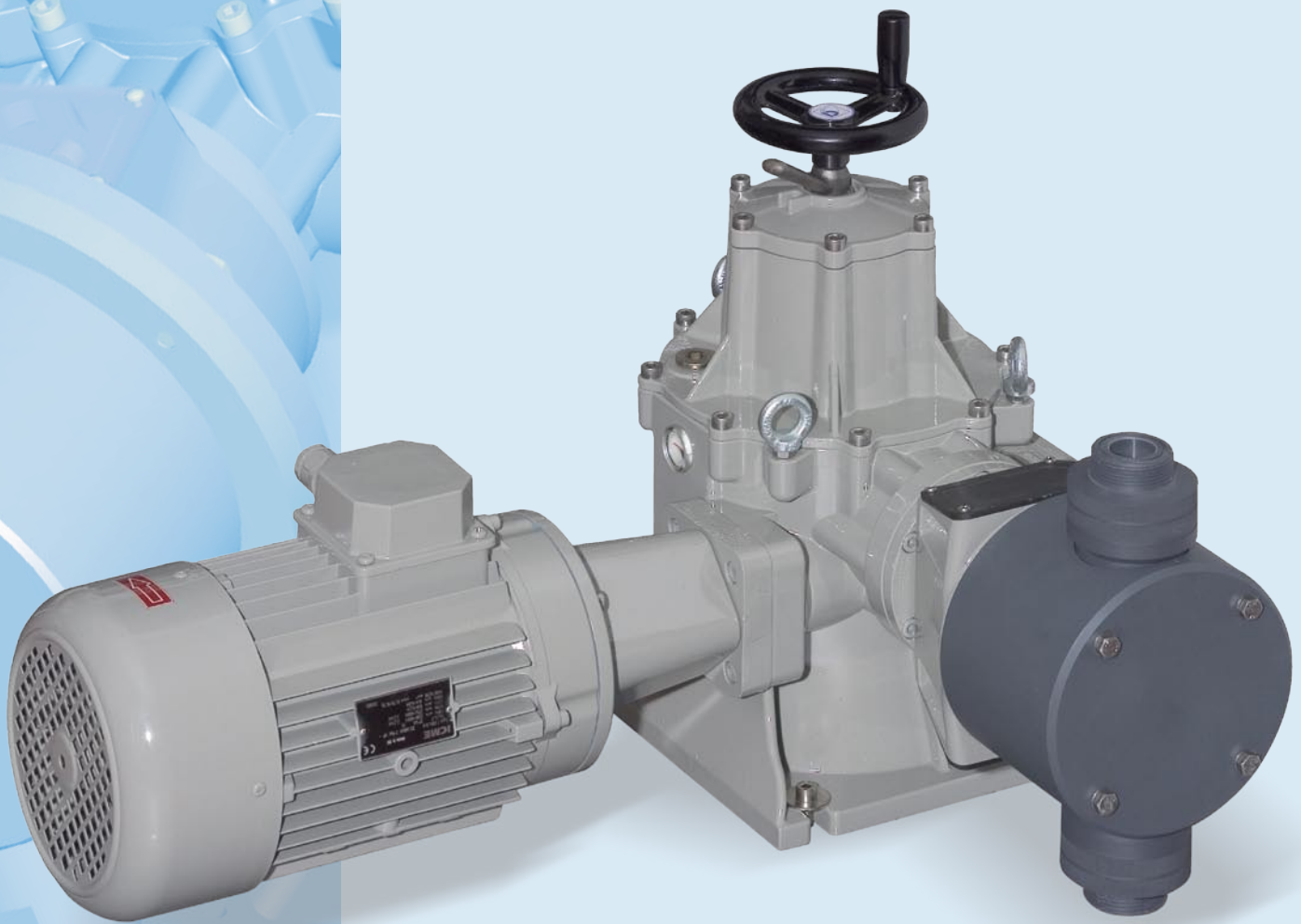

**DOSEURO®**

*The right dosing choice*



# PDP Series

MAIN ELEMENTS TO SUPPORT OUR PRODUCTS

## Versatility

Different piston sizes are available to suit each application, starting from 1,3 until 4,000 l/h.

## Reliability

The high degree of accuracy and reproducibility with high quality materials selection make the piston pump series PDP to assure the maximum reliability.

## Quality

Appropriate materials are selected for each application.

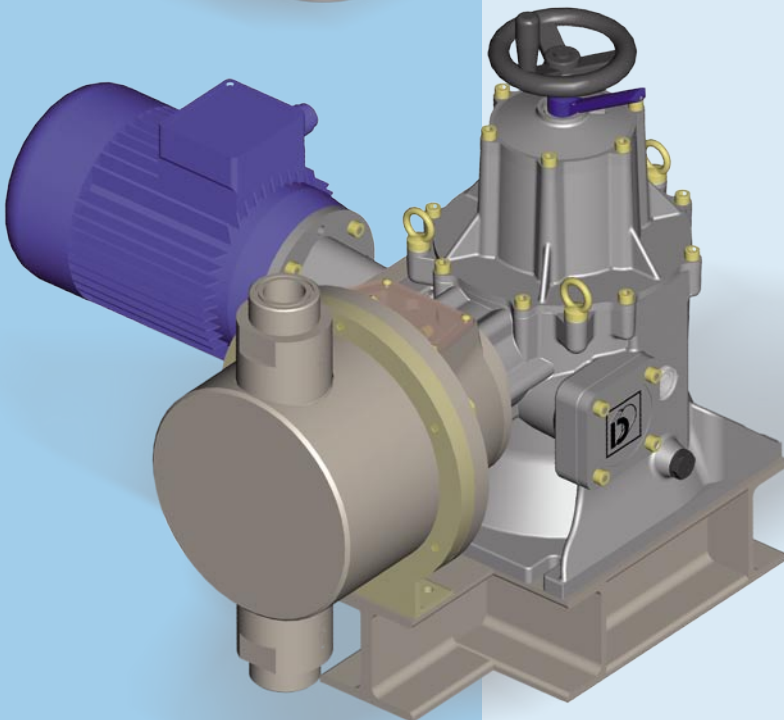
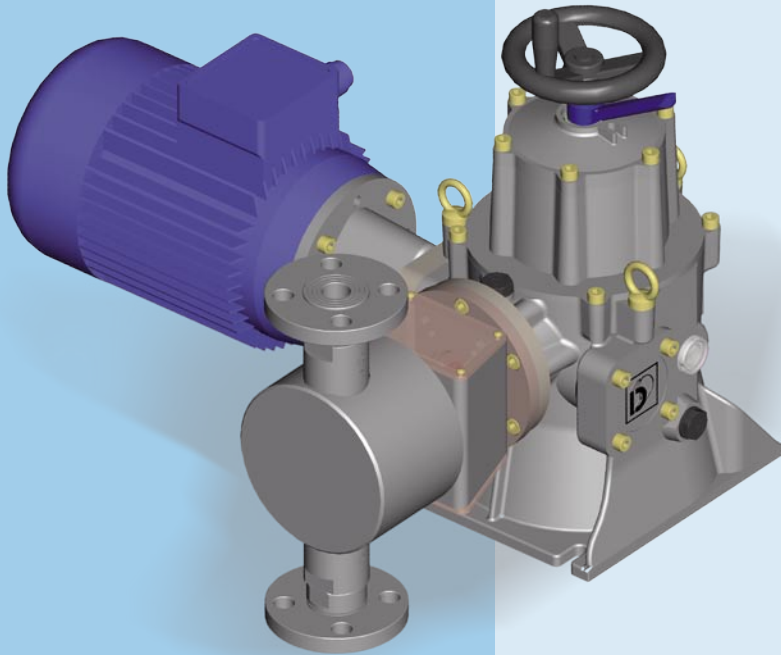

# Positive displacement plunger dosing pump

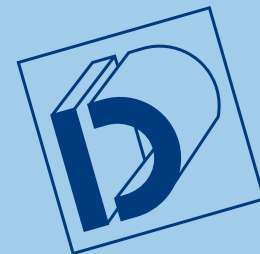

## Type A-I and AP-A I

### FEATURES

PDP series positive displacement plunger dosing pump are manufactured according to API standard 675.

Multiplex drive units with different performances can be coupled between them, independently from the size and stroke number.

Stroke adjustment can be carried with the pump at rest or in operation.

Accuracy is better than 1% from 10 to 100% of maximum output.

Lower NPSH requires with normal operating conditions in function of the head type.

### PUMPING HEADS

Pumping heads are made in standard execution:

S.S. 316 or PVC.

A wide range of other materials like HASTELLOY, ALLOY, PTFE, PVDF, PP are according to the liquid to be dosed.

Piston gaskets are of the lip type design and are available in a wide range of materials ( FPM, EPDM, SILICONE, ADIPRENE).

Liquid handled maximum temperature

- 90°C with S.S. 316 pumps heads.

- 40°C with PVC pump heads.

### PLUNGERS

Are made in S.S. 316 or Ceramics:

### SUCTION AND DISCHARGE CONNECTIONS

Normally are threaded but they can be supplied also flanged.

All the pumps have a ball valve standard

and on the smaller plunger are installed double check valves to improve precision.

### STROKE ADJUSTMENT

Stroke adjustment can be carried out:

- Manual: by a linear micrometer crew.
- Electrical: by servo motor with 4-20 mA signal or upon request interface PROFIBUS or other BUS
- Pneumatic: by pneumatic servo control with signal from 3 to 15 PSI.

### HIGH PRESSURE EXECUTION

These pumps use the same crank mechanism of the pumps "AI " type but the difference is on the hydraulic part that must be suitable to satisfy very hard requirements.

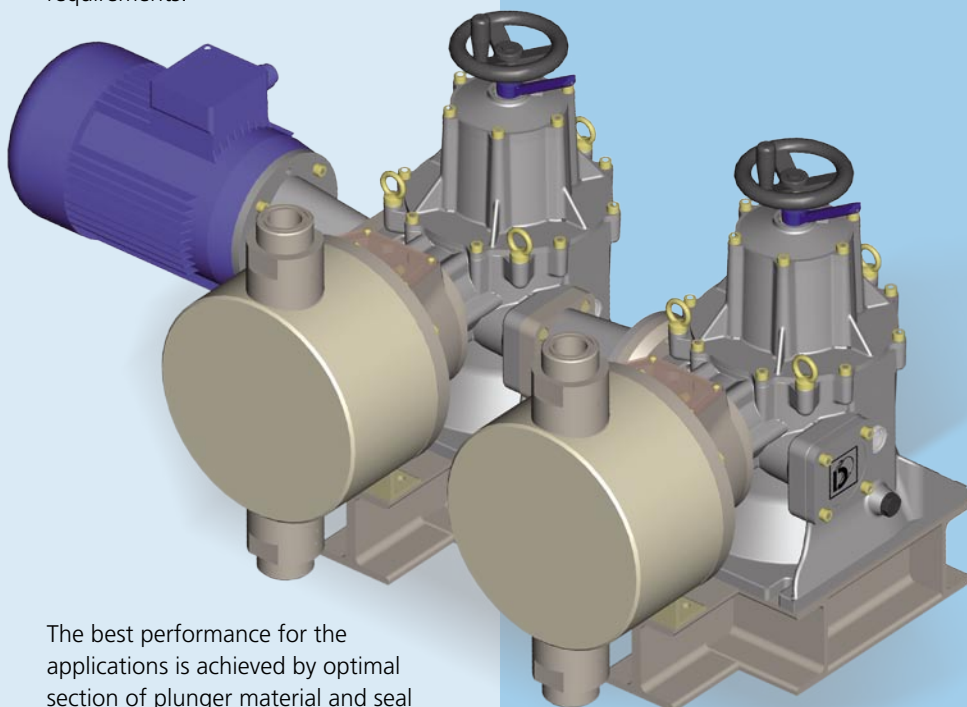

The best performance for the applications is achieved by optimal section of plunger material and seal design.



# PDP Series

## Type A-I 250



### EXECUTION STANDARD MATERIAL

EXECUTION	11	19	13	17	41
<b>Head</b>	S.S. 316L		PVC	S.S. 316L	S.S. 316L
<b>Piston</b>	S.S. 316L		CERAMIC	CERAMIC	CERAMIC
<b>Gasket</b>	NBR	FPM	FPM	FPM	AU
<b>Valve seat</b>	S.S. 316L		PVC	S.S. 316L	S.S. 316L
<b>Valve ball</b>	S.S. 316L		PIREX/PTFE	S.S. 316L	S.S. 316L
<b>Valve gasket</b>	FPM		FPM	FPM	FPM

Other material are available according to the liquid to be dosed.

### GENERAL OVERALL DIMENSIONS

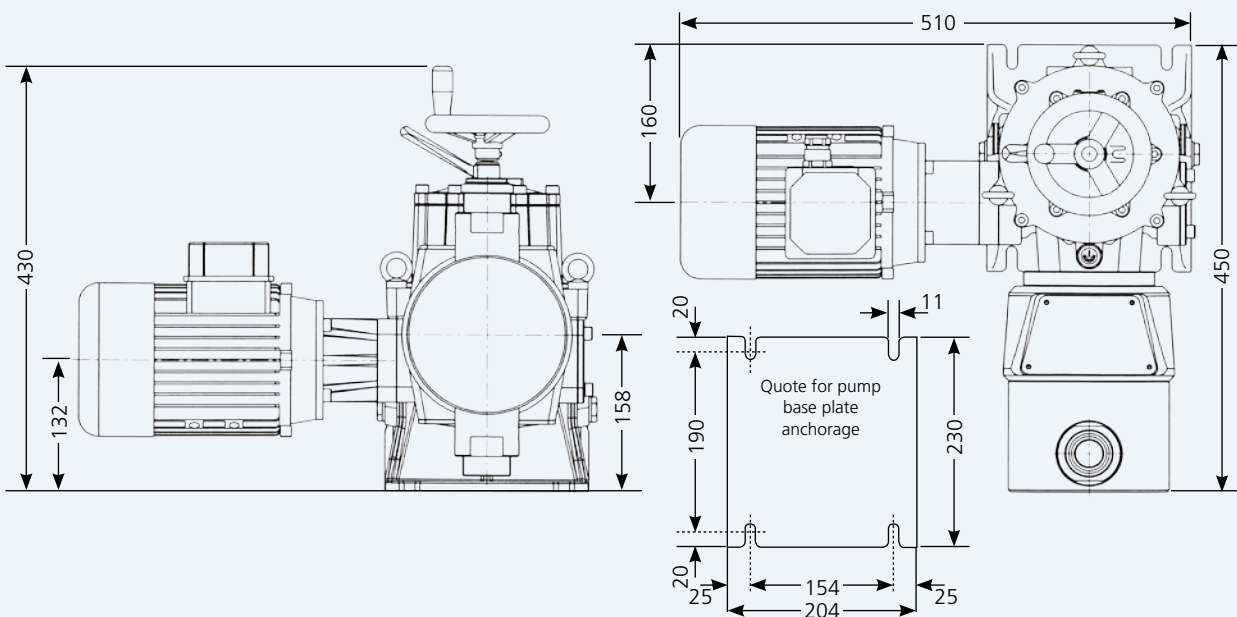

General dimensional quote are indicative and adverted to the maximum acceptable pump dimension

# Positive displacement plunger dosing pump

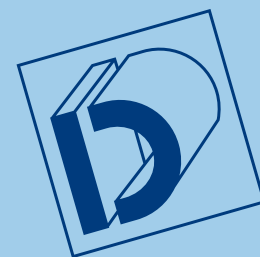

## TECHNICAL CHARACTERISTICS

Pump type	Reducer ratio			Capacity				Max Press. Kg/cm <sup>2</sup>						Connections			Piston Diam.
	(*1)	SPM		L/1'		L/h		SS316			PVC			Threaded	Flanged		
		50 Hz	60 Hz	50 Hz	60 Hz	50 Hz	60 Hz	0,55kw	0,75kw	1,1kw	0,55kw	0,75kw	1,1kw		ø G.m.	UNI	
A-I 250 - 6	I	35	42	0,02	0,024	1,2	1,44	40	//	//	10	//	//	1/2 "	15	1/2 "	6
	F	60	72	0,03	0,040	2	2,4										
	C	96	116	0,05	0,064	3,2	3,8										
	B	120		0,07	0,080	4	4,8										
A-I 250 - 11	F	60	72	0,12	0,140	7	8,4	40	//	//	10	//	//	1/2 "	15	1/2 "	11,11
	C	96	116	0,19	0,224	11,2	13,4										
	B	120		0,23	0,280	14	16,8										
A-I 250 - 18	F	60	72	0,31	0,366	18,3	22,0	40	//	//	10	//	//	1/2 "	15	1/2 "	17,46
	C	96	116	0,49	0,586	29,3	35,2										
	B	120		0,61	0,732	36,6	43,9										
A-I 250 - 25	F	60	72	0,68	0,820	41	49,2	40	//	//	10	//	//	1/2 "	15	1/2 "	25,4
	C	96	116	1,10	1,314	65,7	78,8										
	B	120		1,37	1,640	82	98,4										
A-I 250 - 30	F	60	72	1,02	1,220	61	73,2	40	//	//	10	//	//	1/2 "	15	1/2 "	30,16
	C	96	116	1,63	1,960	98	117,6										
	B	120		2,03	2,440	122	146,4										
A-I 250 - 38	F	60	72	1,62	1,940	97	116,4	26	36	40	10	//	//	1/2 "	15	1/2 "	38,1
	C	96	116	2,60	3,120	156	187,2										
	B	120		3,23	3,880	194	232,8										
A-I 250 - 47	F	60	72	2,53	3,040	152	182,4	17	23	28	10	//	//	3/4 "	20	3/4 "	47,63
	C	96	116	4,07	4,880	244	292,8										
	B	120		5,07	6,080	304	364,8										
A-I 250 - 54	F	60	72	3,27	3,920	196	235,2	13	18	22	10	//	//	3/4 "	20	3/4 "	53,98
	C	96	116	5,22	6,260	313	375,6										
	B	120		6,53	7,840	392	470,4										
A-I 250 - 64	F	60	72	4,52	5,420	271	325,2	9,5	13	16	9,5	10	//	1 "	25	1 "	63,5
	C	96	116	7,22	8,660	433	519,6										
	B	120		9,03	10,840	542	650,4										
A-I 250 - 76	F	60	72	6,50	7,800	390	468,0	6,6	9	11	6,6	9	10	1 "	25	1 "	76,2
	C	96	116	10,40	12,480	624	748,8										
	B	120		13,00	15,600	780	936,0										
A-I 250 - 89	F	60	72	8,85	10,620	531	637,2	4,8	6,6	8	4,8	6,6	8	1 "	25	1 "	88,9
	C	96	116	14,17	17,000	850	1020,0										
	B	120		17,70	21,240	1062	1274,4										
A-I 250 - 98	F	60	72	10,85	13,020	651	781,2	3,9	5,4	6,6	3,9	5,4	6,6	1-1/2 "	40	1-1/2 "	98,43
	C	96	116	17,35	20,820	1041	1249,2										
	B	120		21,70	26,040	1302	1562,4										
A-I 250 - 108	F	60	72	13,03	15,640	782	938,4	3,6	5,2	//	3,6	5,2	//	1-1/2 "	40	1-1/2 "	107,95
	C	96	116	20,87	25,040	1252	1502,4										
A-I 250 - 120	F	60	72	17,00	20,400	1020	1224,0	3,3	4,4	//	3,3	4,4	//	1-1/2 "	40	1-1/2 "	120,65
	C	96	116	27,42	32,900	1645	1974,0										

(\*1) Piston's strokes number during 1 minute with 4 poles installed motor

F = Reducer ratio 1 : 24 = 60 strokes at 50 Hz / 72 strokes at 60 Hz

C = Reducer ratio 1 : 14,5 = 96 strokes at 50 Hz / 116 strokes at 60 Hz

B = Reducer ratio 1 : 11 = 120 strokes at 50 Hz / not suitable

(\*2) The indicated capacity value is subject to changes due to the working pressure, the dosed liquid, the viscosity and the installation asset.





# PDP Series

## Type A-I 350

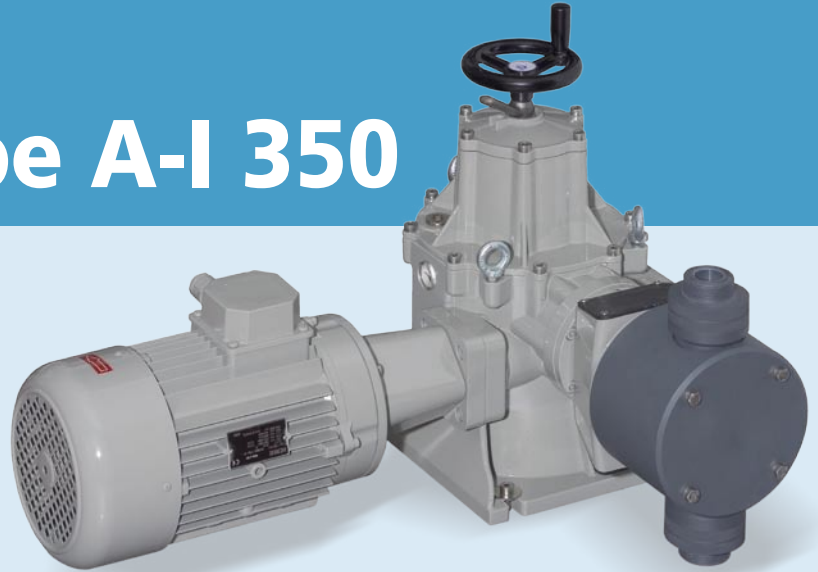

### EXECUTION STANDARD MATERIAL

EXECUTION	11	19	13	17	41
Head	S.S. 316L		PVC	S.S. 316L	S.S. 316L
Piston	S.S. 316L		CERAMIC	CERAMIC	CERAMIC
Gasket	NBR	FPM	FPM	FPM	AU
Valve seat	S.S. 316L		PVC	S.S. 316L	S.S. 316L
Valve ball	S.S. 316L		PIREX/PTFE	S.S. 316L	S.S. 316L
Valve gasket	FPM		FPM	FPM	FPM

Other material are available according to the liquid to be dosed.

### GENERAL OVERALL DIMENSIONS

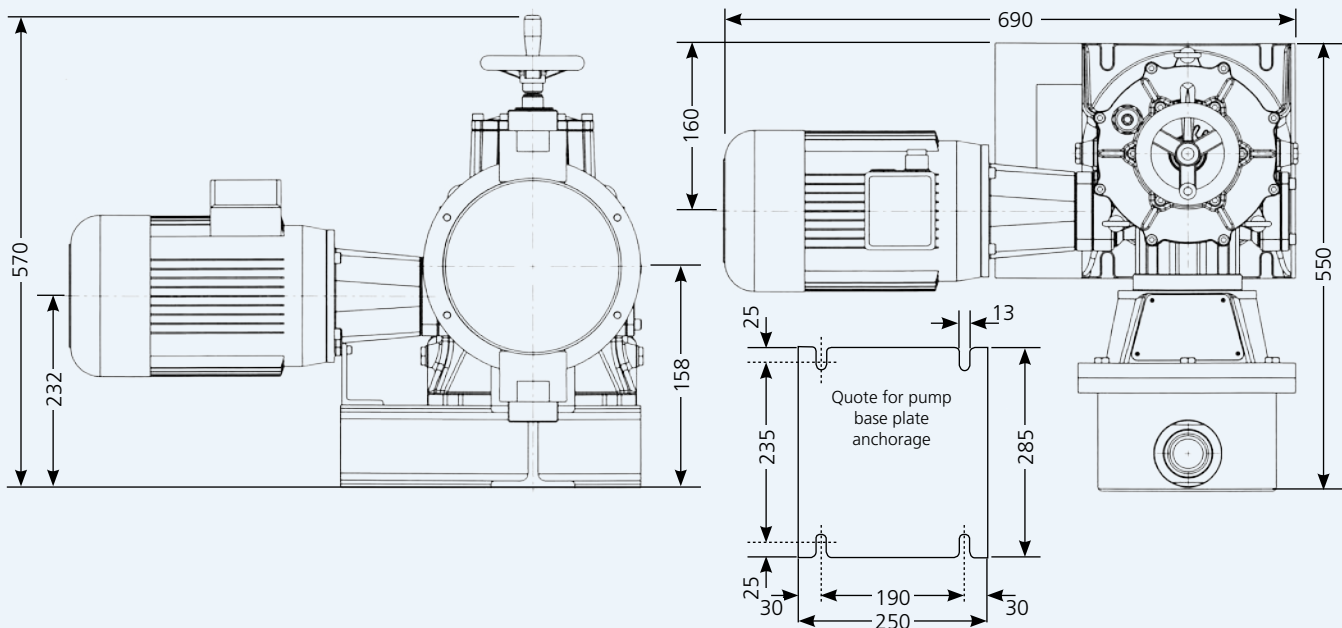

General dimensional quote are indicative and adverted to the maximum acceptable pump dimension

# Positive displacement plunger dosing pump

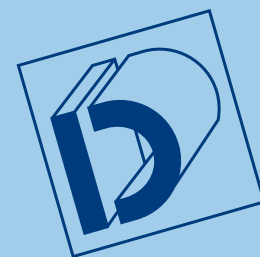

## TECHNICAL CHARACTERISTICS

Pump type	Reducer ratio			Capacity				Max Press. Kg/cm <sup>2</sup>						Connections			Piston Diam.	
	(*)	SPM		L/1'		L/h		SS316			PVC			Threaded ø G.m.	Flanged			
		50 Hz	60 Hz	50 Hz	60 Hz	50 Hz	60 Hz	1,1 Kw	1,5 Kw	2,2 Kw	3 Kw	1,1 Kw	1,5 Kw		2,2 Kw	UNI		ANSI
<b>A-I 350 - 25</b>	F	60	72	0,96	1,150	57,5	69,0											
	C	96	116	1,53	1,840	92	110,4	40	//	//	//	10	//	//	1/2"	15	1/2"	25,4
	B	120		1,92	2,300	115	138,0											
<b>A-I 350 - 30</b>	F	60	72	1,42	1,700	85	102,0											
	C	96	116	2,28	2,740	137	164,4	40	//	//	//	10	//	//	1/2"	15	1/2"	30,16
	B	120		2,83	3,400	170	204,0											
<b>A-I 350 - 38</b>	F	60	72	2,27	2,720	136	163,2											
	C	96	116	3,63	4,360	218	261,6	37,5	40	//	//	10	//	//	3/4"	20	3/4"	38,1
	B	120		4,53	5,440	272	326,4											
<b>A-I 350 - 47</b>	F	60	72	3,55	4,260	213	255,6											
	C	96	116	5,68	6,820	341	409,2	24	32,8	40	//	10	//	//	3/4"	20	3/4"	47,63
	B	120		7,10	8,520	426	511,2											
<b>A-I 350 - 54</b>	F	60	72	4,57	5,480	274	328,8											
	C	96	116	7,30	8,760	438	525,6	18,7	25,5	37,5	40	10	//	//	1"	25	1"	53,98
	B	120		9,13	10,960	548	657,6											
<b>A-I 350 - 64</b>	F	60	72	6,32	7,580	379	454,8											
	C	96	116	10,10	12,120	606	727,2	13,5	18,5	27	31,6	10	//	//	1"	25	1"	63,5
	B	120		12,63	15,160	758	909,6											
<b>A-I 350 - 76</b>	F	60	72	9,10	10,920	546	655,2											
	C	96	116	14,55	17,460	873	1047,6	9,4	12,8	18,8	22	9,4	10	//	1"	25	1"	76,2
	B	120		18,20	21,840	1092	1310,4											
<b>A-I 350 - 89</b>	F	60	72	12,38	14,860	743	891,6											
	C	96	116	19,82	23,780	1189	1426,8	6,9	9,4	13,8	16	6,9	9,4	10	1-1/2"	40	1-1/2"	88,9
	B	120		24,77	29,720	1486	1783,2											
<b>A-I 350 - 98</b>	F	60	72	15,18	18,220	911	1093,2											
	C	96	116	24,28	29,140	1457	1748,4	5,6	7,7	11,3	13	5,6	7,7	10	1-1/2"	40	1-1/2"	98,43
	B	120		30,37	36,440	1822	2186,4											
<b>A-I 350 - 108</b>	F	60	72	18,25	21,900	1095	1314,0											
	C	96	116	29,22	35,060	1753	2103,6	5,1	7	10	//	5,1	7	10	1-1/2"	40	1-1/2"	107,95
<b>A-I 350 - 120</b>	F	60	72	22,80	27,360	1368	1641,6											
	C	96	116	36,50	43,800	2190	2628,0	4,7	6,4	8,7	//	4,7	6,4	8,7	2"	50	2"	120,65
<b>A-I 350 - 127</b>	F	60	72	25,27	30,320	1516	1819,2											
	C	96	116	40,43	48,520	2426	2911,2	4,2	5,8	7,9	//	4,2	5,8	7,9	2"	50	2"	127
<b>A-I 350 - 140</b>	F	60	72	30,58	36,700	1835	2202,0											
	C	96	116	48,92	58,700	2935	3522,0	3,5	4,8	6,5	//	3,5	4,8	6,5	2"	50	2"	139,7
<b>A-I 350 - 152</b>	F	60	72	36,40	43,680	2184	2620,8											
	C	96	116	58,23	69,880	3494	4192,8	2,9	4	5,5	//	2,9	4	5,5	2"	50	2"	152,40
<b>A-I 350 - 160</b>	F	60	72	39,50	47,400	2370	2844,0											
	C	96	116	63,33	76,000	3800	4560,0	2,7	3,7	5	//	2,7	3,7	5	2"	50	2"	158,8

(\*)1) Piston's strokes number during 1 minute with 4 poles installed motor

F = Reducer ratio 1 : 20 = 70 strokes at 50 Hz / 84 strokes at 60 Hz

C = Reducer ratio 1 : 14,5 = 96 strokes at 50 Hz / 116 strokes at 60 Hz

B = Reducer ratio 1 : 11 = 120 strokes at 50 Hz / not suitable

(\*)2) The indicated capacity value is subject to changes due to the working pressure, the dosed liquid, the viscosity and the installation asset.



# PDP Series

## Type AP-A I 250

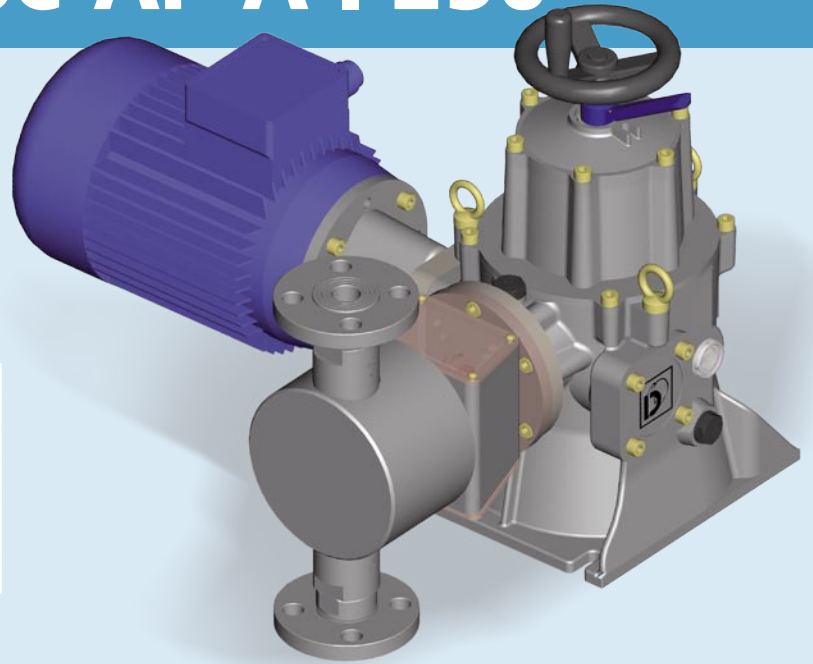

### EXECUTION STANDARD MATERIAL

EXECUTION	32	41
Head	S.S. 316L	S.S. 316L
Piston	S.S. 420 Temp.	CERAMIC
Gasket	COT+NBR	COT+NBR
Valve seat	S.S. 316L	S.S. 316L
Valve ball	S.S. 316L	S.S. 316L
Valve gasket	FPM	FPM

Other material are available according to the liquid to be dosed.

Pump type	Reducer ratio			Capacity				Max Press. Kg/cm <sup>2</sup>			Connections			Piston Diam. ø mm
	(*)	SPM		L/1'		L/h		S.S.316			Thread. ø G.m.	Flanged		
		50 Hz	60 Hz	50 Hz	60 Hz	50 Hz	60 Hz	0,55 Kw	0,75 Kw	1,1 Kw		UNI	ANSI	
AP-A I 250 - 8	I	35	42	0,04	0,044	2,2	2,64	250	//	//	1 / 2 "	15	1 / 2 "	8
	F	60	72	0,06	0,076	3,8	4,56							
	C	96	116	0,10	0,122	6,1	7,3							
	B	120		0,13	0,152	7,6	9,1							
AP-A I 250 - 12	F	60	72	0,15	0,176	8,8	10,6	250	//	//	1 / 2 "	15	1 / 2 "	12
	C	96	116	0,24	0,284	14,2	17,0							
	B	120		0,29	0,352	17,6	21,1							
AP-A I 250 - 16	F	60	72	0,27	0,322	16,1	19,3	150	203	248	1 / 2 "	15	1 / 2 "	16
	C	96	116	0,43	0,516	25,8	31,0							
	B	120		0,54	0,644	32,2	38,6							
AP-A I 250 - 22	F	60	72	0,51	0,616	30,8	37,0	79	107	131	1 / 2 "	15	1 / 2 "	22
	C	96	116	0,82	0,986	49,3	59,2							
	B	120		1,03	1,232	61,6	73,9							
AP-A I 250 - 25	F	60	72	0,70	0,840	42	50,4	61	83	102	1 / 2 "	15	1 / 2 "	25
	C	96	116	1,12	1,340	67	80,4							
	B	120		1,40	1,680	84	100,8							
AP-A I 250 - 30	F	60	72	1,00	1,200	60	72,0	42	58	70	3 / 4 "	20	3 / 4 "	30
	C	96	116	1,62	1,940	97	116,4							
	B	120		2,00	2,400	120	144,0							
AP-A I 250 - 35	F	60	72	1,37	1,640	82	98,4	31	42	52	3 / 4 "	20	3 / 4 "	35
	C	96	116	2,20	2,640	132	158,4							
	B	120		2,73	3,280	164	196,8							

(\*)1) Piston's strokes number during 1 minute with 4 poles installed motor

I = Reducer ratio 1 : 40 = 35 strokes at 50 Hz / 42 strokes at 60 Hz

F = Reducer ratio 1 : 24 = 60 strokes at 50 Hz / 72 strokes at 60 Hz

C = Reducer ratio 1 : 14,5 = 96 strokes at 50 Hz / 116 strokes at 60 Hz

B = Reducer ratio 1 : 12 = 120 strokes at 50 Hz / 144 strokes at 60 Hz

(\*)2) The indicated capacity value is subject to changes due to the working pressure, the dosed liquid, the viscosity and the installation asset.



# Positive displacement plunger dosing pump

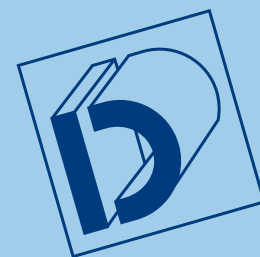

## Type AP-A I 350

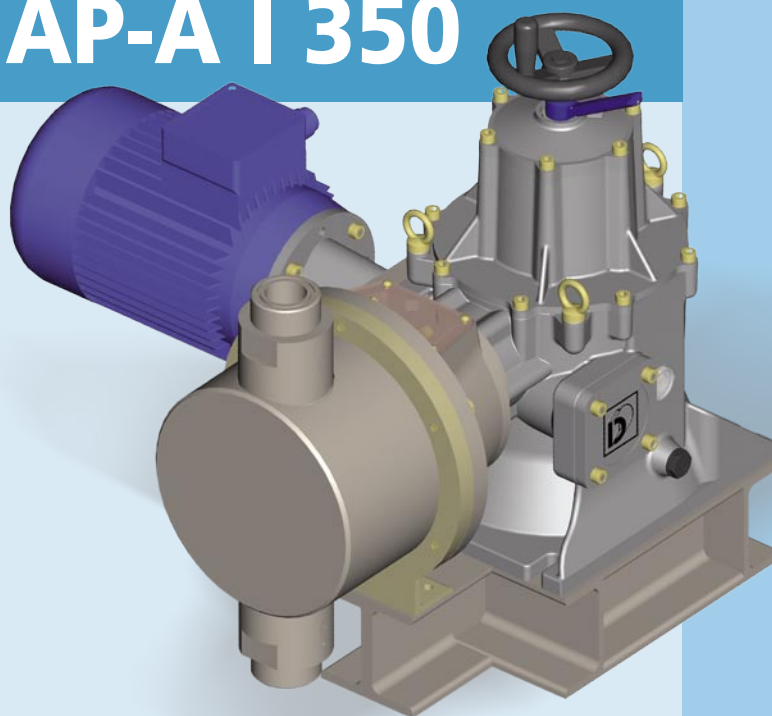

Pump type	Reducer ratio			Capacity				Max Press. Kg/cm <sup>2</sup>				Connections			Piston Diam. ø mm
	(*)	SPM		L/1'		L/h		S.S.316				Thread.	Flanged		
		50 Hz	60 Hz	50 Hz	60 Hz	50 Hz	60 Hz	1,1 kW	1,5 kW	2,2 kW	3 kW	ø G.m.	UNI	ANSI	
AP-A I 350 - 16	F	60	72	0,36	0,430	21,5	25,8	213	250	//	//	1 / 2 "	15	1 / 2 "	16
	C	96	116	0,58	0,690	34,5	41,4								
	B	120		0,72	0,860	43	51,6								
AP-A I 350 - 22	F	60	72	0,70	0,842	42,1	50,5	112	153	225	250	1 / 2 "	15	1 / 2 "	22
	C	96	116	1,12	1,348	67,4	80,9								
	B	120		1,41	1,686	84,3	101,2								
AP-A I 350 - 25	F	60	72	0,95	1,140	57	68,4	87	119	174	204	1 / 2 "	15	1 / 2 "	25
	C	96	116	1,48	1,780	89	106,8								
	B	120		1,90	2,280	114	136,8								
AP-A I 350 - 30	F	60	72	1,42	1,700	85	102,0	60	82	121	141	3 / 4 "	20	3 / 4 "	30
	C	96	116	2,27	2,720	136	163,2								
	B	120		2,83	3,400	170	204,0								
AP-A I 350 - 35	F	60	72	1,92	2,300	115	138,0	45	61	89	104	3 / 4 "	20	3 / 4 "	35
	C	96	116	3,07	3,680	184	220,8								
	B	120		3,83	4,600	230	276,0								
AP-A I 350 - 40	F	60	72	2,50	3,000	150	180,0	34	46	68	80	3 / 4 "	20	3 / 4 "	40
	C	96	116	4,00	4,800	240	288,0								
	B	120		5,00	6,000	300	360,0								
AP-A I 350 - 50	F	60	72	3,92	4,700	235	282,0	22	30	44	51	1 "	25	1 "	50
	C	96	116	6,27	7,520	376	451,2								
	B	120		7,83	9,400	470	564,0								

(\*)1) Piston's strokes number during 1 minute with 4 poles installed motor

F = Reducer ratio 1 : 24 = 60 strokes at 50 Hz / 72 strokes at 60 Hz

C = Reducer ratio 1 : 14,5 = 96 strokes at 50 Hz / 116 strokes at 60 Hz

B = Reducer ratio 1 : 12 = 120 strokes at 50 Hz / 144 strokes at 60 Hz

(\*)2) The indicated capacity value is subject to changes due to the working pressure, the dosed liquid, the viscosity and the installation asset.



# PDP Series

## Correct installation and

### THE BENEFITS OF FLUID CONTROL ASSURE

- Increase efficiency and pump life.
- Decrease maintenance and operating costs.

The control of fluid dynamics is essential to ensure efficient and safe use of process systems. Uncontrolled fluid in motion can physically destroy a pumping system including the pumping, valves, meters, back pressure valves, in-line instrumentation and equipment.

### 1 FILTERS

We suggest to install filters (on the suction pipe) to keep back impurities that can be presented on liquid to dose or coming from pipeline system. The use of filters assures a trouble-free dosing.

### 2 SAFETY VALVES

Safety valves are designed to protect the pump and chemical feed system from over pressure damage 'caused by defective equipment or a blockage in the chemical feed line.

### 2 SAFETY VALVES

### 4 PULSATION DAMPENERS

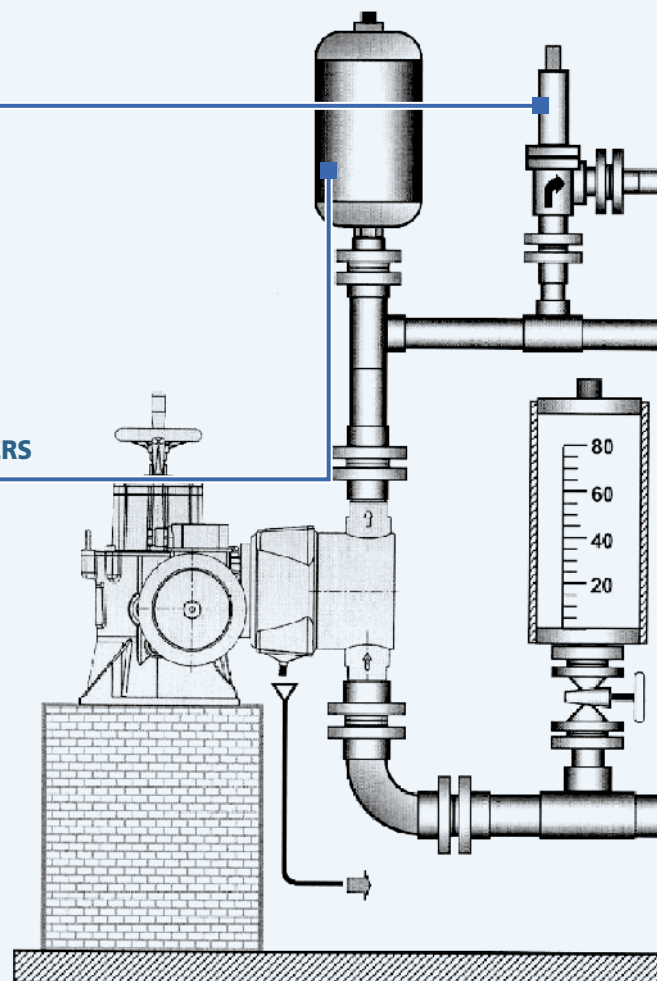



# Positive displacement plunger dosing pump

## accessories

### 3 BACK PRESSURE VALVES

Back pressure valves apply positive discharge pressure to a metering pump system to prevent siphoning and eliminate varying down-stream pressure.

### 4 PULSATION DAMPENER

Metering pumps have a pulsating flow. Both positive displacement pumps and quick closing valves start and stop fluids that are in motion. Positive displacement pumps derive their pumping action by capturing a given amount of fluid in a chamber and pushing it out the pump's

discharge. Each pump cycle includes a suction stroke during which fluid flow is stopped. This pumping action produces an acceleration/deceleration of the fluid, creating units of uncontrolled energy, resulting in PULSATION, observed as pressure spikes.

Pulsation dampener is required for two reasons:

- To reduce high, non - permissible pressure fluctuations.
- To create a nearly continuous flow.

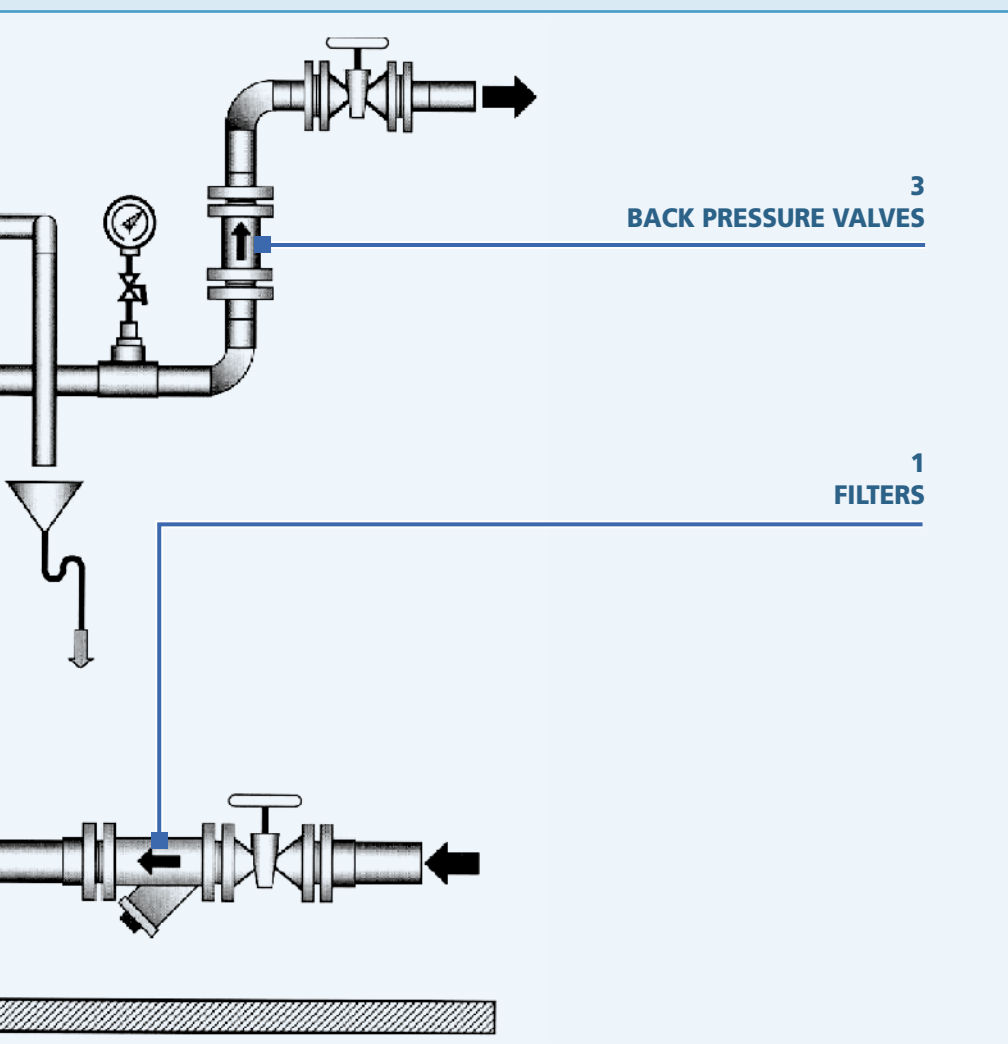



Our range of production also includes:

**SR series:**

- Plunger dosing pumps "A" types
- Hydraulic diaphragm dosing pumps "B", "BR" and "SD" types
- Mechanical diaphragm dosing pumps "D" types
- Mechanical diaphragm dosing pumps "FM" types

**SDP series:**

- Solenoid dosing pumps "S" type
- Solenoid dosing pumps "GA" type

**H series:**

Automatic plants for dissolution and preparation of powder polyelectrolytes "HA", "HB" types

**EM series:**

Electric mixers for chemical mixing "DMT", "DEM", "DRV" and "DRC" types



**HEAD OFFICE**

Via G. Carducci 141  
 20093 Cologno Monzese (MI) Italy  
 Tel.: +39 02 27301324  
 Fax: +39 02 26700883  
 e-mail: info@doseuro.com  
 www.doseuro.com

**DOSEURO (UK) LTD.**

Unit 8, East Road Industrial Estate  
 Sleaford, Lincolnshire NG34 7EH  
 Tel.: +44 1529 300045  
 Fax: +44 1529 410967  
 e-mail: info@doseuro.co.uk  
 www.doseuro.co.uk



**DOSEURO®**  
*The right dosing choice*