



REPORT

issued by an Accredited Testing Laboratory

Contact person
Malin Mollsjö
Fire Research
+46 10 516 57 14
Malin.Mollsjo@sp.se

Date
2015-10-16

Reference
4P06753rev2EN

Page
1 (6)



Stofix AB
Kumla Gårdsvägen 21
145 63 Norsborg
Sweden

Fire test of a facade cladding

(30 appendices)

Test method

This report details the method of construction, the test conditions and the results obtained when the specific element of construction described herein was tested following the procedure outlined in the accredited test method

- SP FIRE 105, issue 5, dated 1994-09-09

Product

Facade cladding

Product designation

Stofix - tegelbeklädning / Stofix - brick cladding

Sponsor

Stofix AB
Kumla Gårdsvägen 21
145 63 Norsborg
Sweden

Reference number

4P06753rev2EN

SP Technical Research Institute of Sweden

Postal address
SP
Box 857
SE-501 15 BORÅS
Sweden

Office location
Västeråsen
Brinellgatan 4
SE-504 62 BORÅS

Phone / Fax / E-mail
+46 10 516 50 00
+46 33 13 55 02
info@sp.se

Laboratories are accredited by the Swedish Board for Accreditation and Conformity Assessment (SWEDAC) under the terms of Swedish legislation. This report may not be reproduced other than in full, except with the prior written approval of the issuing laboratory.

1 Purpose of the test

The purpose of the test was to determine the fire spread in the facade cladding described in chapter 2.

2 Test construction

2.1 General information

The test specimen consisted of brick panels mounted on steel profiles with insulation made of PIR behind. The construction of the test specimen can be seen in the description in chapter 2.2 below and in the sponsor's drawings and specifications in appendices 1 – 23. In case the sponsor's drawings do not correspond to the construction of the test specimen, SP has crossed details or altered the drawings.

2.2 Description of the test specimen

The dimensions of the facade cladding were (width x height) 4000 x 6000 mm and were mounted on a wall of lightweight concrete on SP's test rig for facade claddings.

On the wall of lightweight concrete wall brackets of galvanized steel designated SK 165 were mounted on the maximum centre distance 600 mm in horizontal direction and 700 mm in vertical direction. The wall was insulated with 20 mm mineral wool insulation (to cover irregularities), 100 mm PIR insulation designated SPU AL with nominal density 32-36 kg/m³ and 50 mm mineral wool insulation designated Västskustskiva with nominal density 85 kg/m³. The insulation was fixed to the wall with the wall brackets and approximately three plastic plugs per slab.

On the wall brackets vertical insulation rails were mounted. In the insulation rails horizontal mounting rails were mounted. In the mounting rails the brick panels were mounted. The brick panels were constructed of a frame of galvanized steel sheet, brick panels and mortar according to appendix 7. On the back sides of the panels there were support tongues which were used to mount the panels to the mounting rails. The panels were attached to each other with three self-drilling screws in the vertical joint and three in the horizontal joint. The joints between the panels were joined with Stofix Fogbruk.

Between the insulation and the brick panels was an air cavity of 35 mm.

Around the window openings and in the lower edge of the facade window sheets of steel were mounted.

The construction of the facade cladding can be seen in the sponsor's drawings and descriptions in appendices 1-23.

2.3 Delivery and assembly of the test specimen

The material to the test specimen was selected and delivered to SP by the sponsor. The material arrived to SP on November 26, 2014. Manufacturer of the material were Stofix OY and SPU Isolering AB. The test specimen was assembled on a wall of lightweight concrete on SP’s test rig for facade claddings. The test specimen was assembled by the sponsor on November 27-28, 2014. The assembly of the test specimen was overseen by SP. The test setup is shown in appendix 24.

2.4 Conditioning

The facade cladding was stored in SP's furnace hall before the test. The temperature in the hall was in average 17 °C and the relative humidity was in average 55 % during this time.

2.5 Verification

2.5.1 Verification of the test specimen

The verification that the test specimen corresponded to the drawings and specifications provided by the sponsor was performed during the mounting of the test specimen in SP’s furnace hall.

2.5.2 Properties of included materials

<i>Material</i>	<i>Density (kg/m³)</i>	<i>Moisture ratio¹⁾ (%)</i>	<i>Moisture ratio²⁾ (%)</i>
Stone wool (Västkustskiva)	70	0,8	3,2
PIR insulation	35	-	-

- 1) Moisture ratio calculated from weight loss after being heated at 105 °C.
- 2) Moisture ratio calculated from weight loss after being heated at 500 °C.

The verification was performed on December 2, 2014 on samples taken during the mounting of the test specimen in SP’s premises.

The purpose of the control is to verify material data and dimensions of materials and components included in the test specimen. The extent of performed measurements and applied methodology can deviate from standardized method. The results shall therefore not be considered as formal material data.

3 Test procedure and test results

The test was performed on December 8, 2014 in SP's large fire test hall.

3.1 Test conditions

The fire source consisted of 60 litres heptane in trays, placed as shown in appendix 24. The test was terminated when the fire source had finished. The test lasted 17 minutes.

The air temperature was 17,5 °C and the relative humidity was 41 % in the test hall at the start of the test.

3.2 Witness of test

The test was witnessed by Matti Väyrynen from Stofix AB and Kenneth Finnäs from SPU Isolering AB.

3.3 Measurements

3.3.1 Temperatures

The temperature at the eave was measured with two thermocouples (C1 – C2). The placement of the thermocouples is shown in appendix 25.

The measured temperatures at the eave are shown in appendix 26.

Extra temperature measurements were made on the insulation. The placement is shown in appendix 24 and the measured temperatures are shown in appendix 27.

3.3.2 Heat flux

The heat flux against the test specimen was measured with one heat flux meter. The heat flux meter was placed at the centre of lower fictitious window. The manufacturer of the heat flux meter was Medtherm.

The measured heat flux at the centre of the lower fictitious window is shown in appendix 28.

3.4 Observations

Photographs taken in connection with the test are shown in appendix 29.

3.4.1 Observations during the test

<i>Time min:s</i>	<i>Observations</i>
00:00	The fire source of heptane ignites. The test starts.
02:00	Some smoke emerge from the fire room.
03:00	Thick black smoke emerge from the fire room.
03:20	Flames emerge from the fire room. Still thick black smoke in front of the facade.
03:50	Flames reach the lower edge of the lower window.
04:30	Flames reach the upper edge of the lower window.
07:00	Flames reach just above the upper edge of the lower window.
08:50	A weak clicking sound is heard from the facade.
09:00	Occasional flames reach half the height of the facade.
10:00	Occasional flames reach the lower edge of the upper window.
11:40	A weak clicking sound is heard from the facade.
11:50	Small pieces of joint shoots off from the facade.
12:20	Occasional flames reach the lower edge of the upper window.
14:00	It is burning in the lower left corner of the lower window.
14:30	Flames reach half the height of the facade.
14:40	Small burning drops fall to the floor in front of the facade.
15:40	Small burning drops fall to the floor in front of the facade.
16:00	Flames decrease.
16:30	Flames reach to lower edge of the facade.
16:30	Flames reach just out from the fire room.
16:00	The test terminates. The fire source has become extinct and the facade is extinguished with water.

3.4.2 Observations after the test

There are cracks in the bricks at the lower left corner of the lower window. There are small cracks in the bricks and the joints below the lower edge of the lower window.

At the lower edge of the facade, along the fire room opening, the insulation (both PIR and mineral wool/Västkustskiva) is charred. Just above, the PIR insulation is charred 1-2 cm. The mineral wool/Västkustskiva is discoloured at the surface below the lower window. All around the lower window the PIR insulation is charred 1-2 cm and discoloured 1-2 cm. All around the upper window the PIR insulation is discoloured.

The fire spread did not reach a bit above the upper edge of the lower window.

The fire damage of the insulation is shown in appendix 30.

4 Summary

The test specimen, described in chapter 2, has been fire tested according to SP FIRE 105, issue 5, dated 1994-09-09 during 17 minutes. The following results were obtained:

- No large pieces fell down from the facade cladding that can cause danger for evacuating people or rescue personnel.
- The fire spread in the surface and inside the facade cladding was limited and did not reach above the lower edge of the window in the second storey above the fire room.
- The temperature at the eave did not exceed 500 °C during a continuous period of more than 2 minutes.
- The temperature at the eave did not exceed 450 °C during a continuous period of more than 10 minutes.
- The heat flux against the centre of the window in the first storey above the fire room did not exceed 80 kW/m².

The test results relate only to the behaviour of the test specimen during the conditions of the test. At other conditions, for instance another fire condition, the behaviour of the construction may differ from the presented test results.

This is a translation from the Swedish original test report 4P06753rev2, dated 2015-05-06. In the event of any dispute as to the content of the document, the Swedish text shall take precedence.

SP Technical Research Institute of Sweden Fire Research - Fire Resistance

Performed by

Examined by

Malin Mollsjö

Patrik Johansson

Appendices:

1 – 30 (one page per appendix)

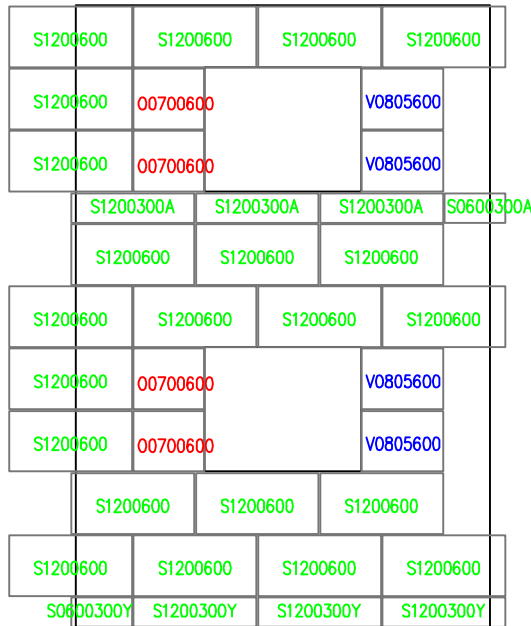

REF: 4P06753rev2EN
APP: 1-23

Titel	Antal
Monterings skena	19
Isolerings skena	18
Väggfäste	70
Netto yta	20,38m ²
Elements yta	21,97m ²
Hörnelements löpmeter	4,8m

Del	Kortelnr.	Tomtnr.	Myndighets anteckningar		
Byggnads åtgärd Brandtest			Ritning Huvudritning	Löpnr.	
Byggnads namn och adress SP Fire 105 Brandtest			Ritningsinnehåll Beklädnadsplanering	Skala 1:100	
			Ritning ARK	Arbetsnr.	Ritningsnr. Ändring
			Datum 29.10.2014	Kontaktperson MVÄ	
STONEL OY Ahimäntinkatu 2E, PL3 40100 JYVÄSKYLÄ			tel. 0207 959 300 fax. 0207 959 301 www.stonel.fi	Setu Petäjä, RI	



STOFIX AB
Kumla Gårdsväg 21
145 63 Norsborg
SVERIGE
tel. +46 8 531 92 228
fax +46 8 531 92 227
www.stofix.se

STOFIX Brick Cladding System

Typ av detalj:
SP Fire 105

LINTEL AND SILL DETAIL

STOFIX brick cladding with ventilation cavity
50mm wind protection slab
100mm SPU insulation AL
20mm mineral wool

Datum 2014-11-11

Skala 1:5

Arbetsnr:

1010

Ritningsnr:

2023

Rit/konstr av Stofix Ab Matti Väyrynen

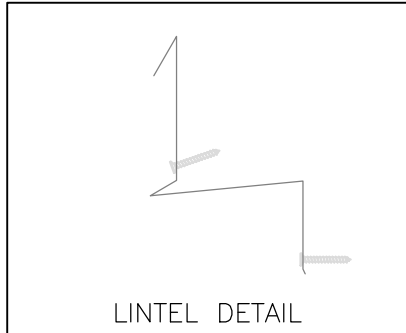

LINTEL DETAIL

Plate preventing water ascent

Ventilation gap

Plate holes for drainage

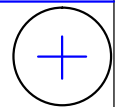
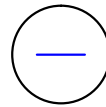
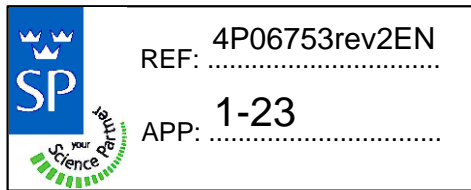

Window sill support with angle bracket

Ventilation gap
Sheet metal that prevents water ascent

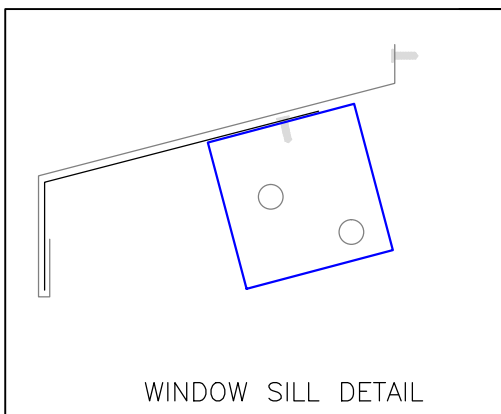

WINDOW SILL DETAIL

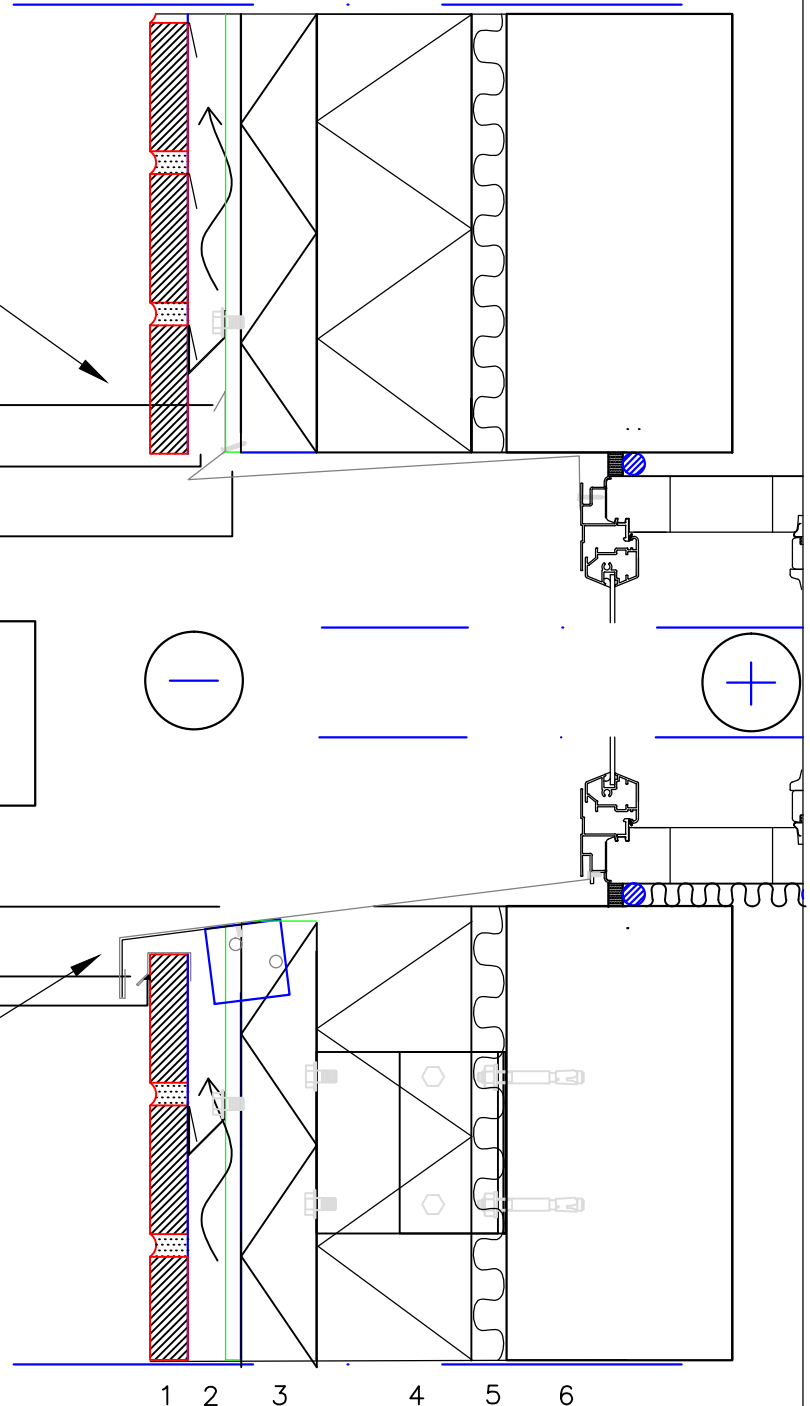

1. STOFIX brick cladding 20 mm
2. Ventilation cavity 35 mm
3. STOFIX insulation rail / mineral wool wind protection slab 50 mm
4. SPU insulation AL 100 mm
5. Mineral wool 20mm
6. Backing wall

**STOFIX AB**

Kumla Gårdsväg 21
145 63 Norsborg
SVERIGE
tel. +46 8 531 92 228
fax +46 8 531 92 227
www.stofix.se

STOFIX Brick Cladding System

Typ av detalj:

SP Fire 105

VERTICAL WINDOW CONNECTION DETAIL WITH PISTOL SLIPS
STOFIX brick cladding
50mm wind protection slab
100mm SPU insulation AL
20mm mineral wool

Datum 2014-11-11

Skala 1:5

Arbetsnr:

1010

Ritningsnr:

2025

Rit/konstr av

Stofix Ab Matti Väyrynen

1. STOFIX brick cladding 20 mm
2. Ventilation cavity 35 mm
3. STOFIX insulation rail/ mineral wool wind protection slab 50 mm
- 4 SPU insulation AL 100mm
- 5 Mineral wool 20 mm

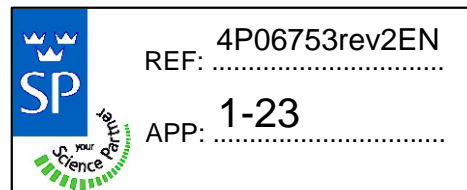

WINDOW JAMB FLASHING, DETAIL

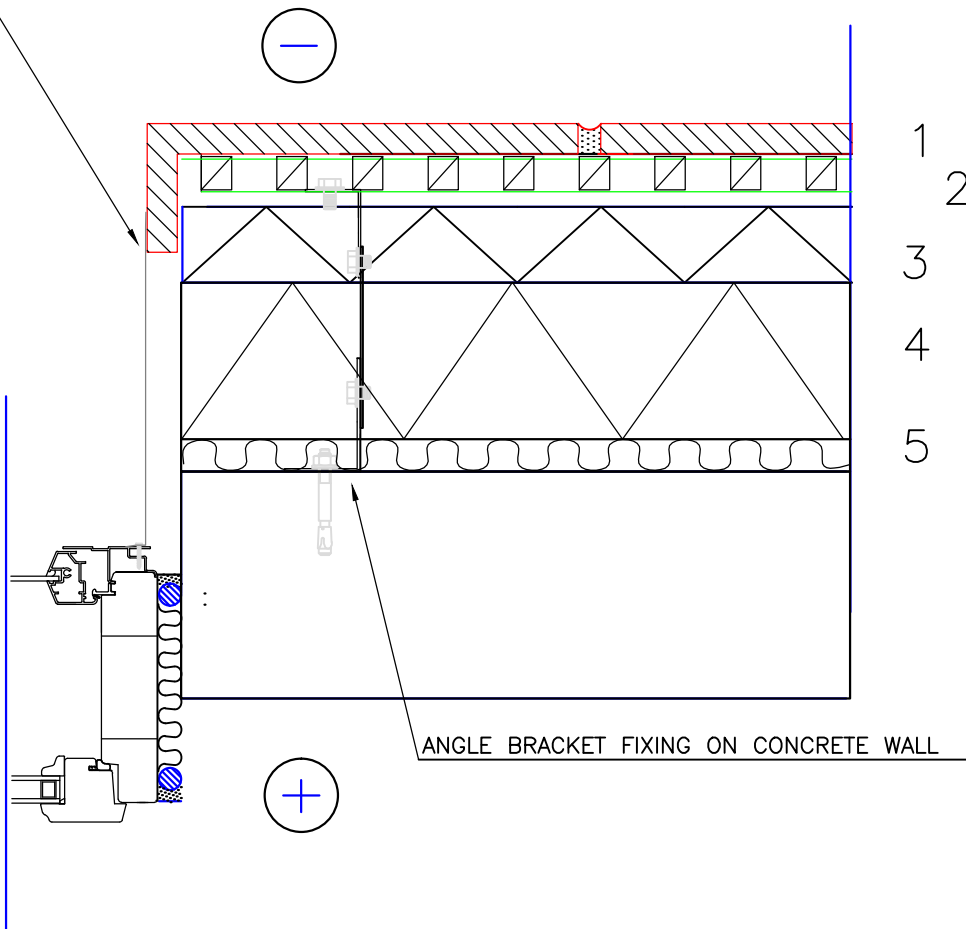

ANGLE BRACKET FIXING ON CONCRETE WALL

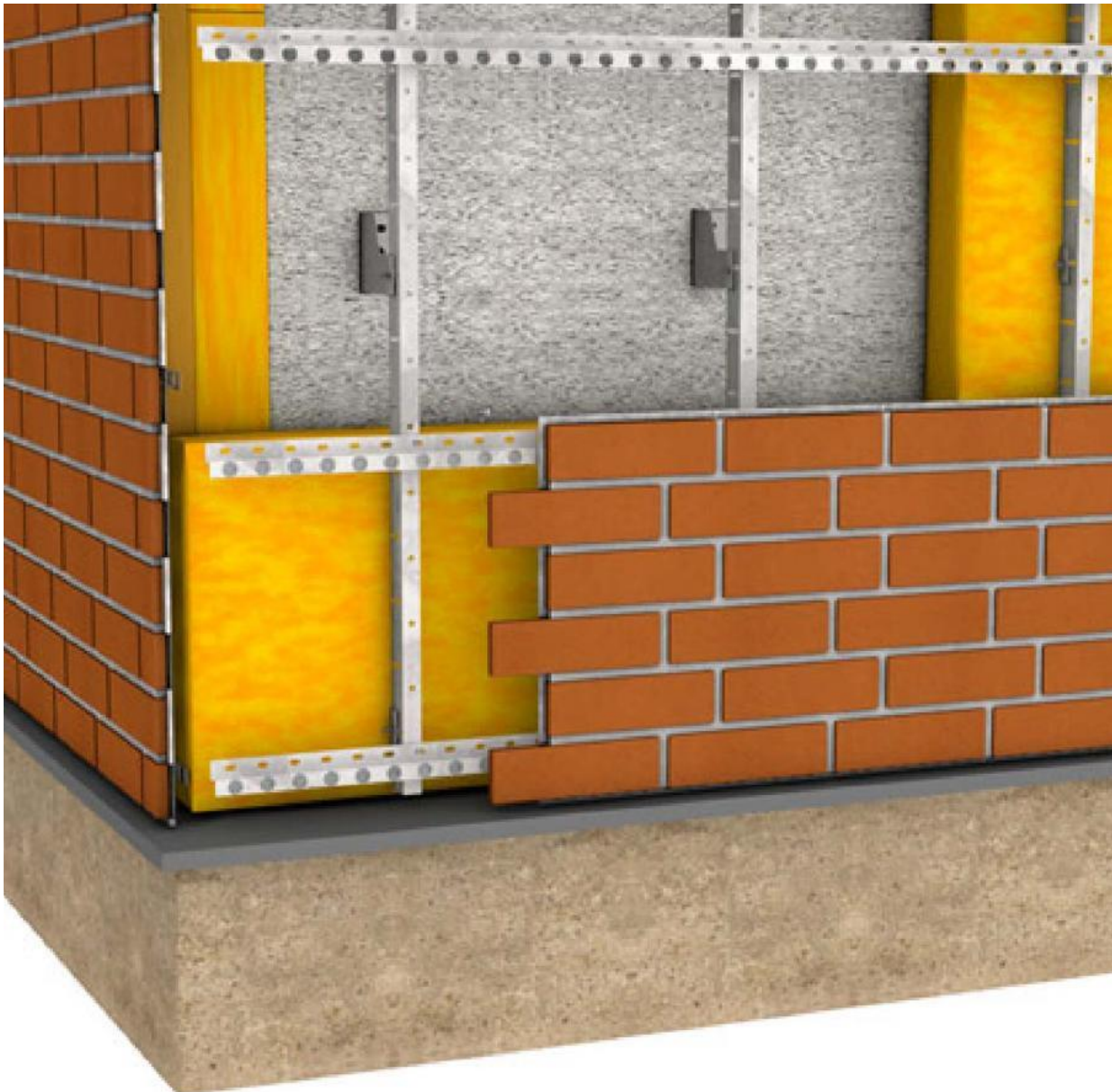

PLANNING AND INSTALLATION INSTRUCTIONS

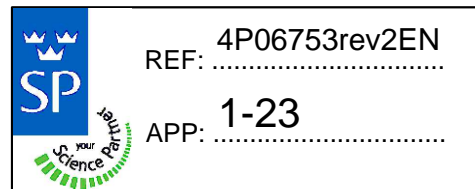

Sisällysluettelo

PLANNING AND INSTALLATION INSTRUCTIONS.....	1
1 General	3
2 Project Design	3
2.1 Technical Specifications	4
2.2 Exploded View.....	5
2.3 Dimension Diagrams.....	6
2.3.1 Stofix Brick Panel	6
2.4 Stofix Mounting System	8
2.4.1 Mounting Rail.....	9
2.4.2 Insulation Rail	9
2.4.3 Mounting Brackets	10
3 Installation	13
3.1 Preparation	13
3.2 Storage	13
3.3 Installation of the Stofix Mounting System	13
3.3.1 Bottom Plate.....	13
3.3.2 Wall Brackets.....	13
3.3.3 Ties to External Skin	14
3.3.4 Installation and Adjustment of Insulation Rails	14
3.3.5 Coupling Bracket.....	14
3.3.6 Insulation.....	15
3.3.7 Installation of Mounting Rails.....	15
3.3.8 Cutting.....	15
3.4 Installation of Stofix Brick Cladding	16
3.4.1 Installation of Mounting Rails for Cladding with No Insulation	16
3.4.2 Installation of Brick Panels	16
3.4.3 Coupling the Panels	17
3.4.4 Cutting.....	17
3.4.5 Grouting the Joints on Site	17
3.4.6 Expansion Joints	17
3.4.7 Flashings.....	19
3.4.8 Finishing	19
4 Instructions for Installing Hardware on Stofix Brick Panel Walls	20
4.1 Lightweight Structures	20
4.2 Heavy Structures	20

1 General

The Stofix façade system is suitable for brick and tile facades. Stofix brick cladding is a combined structure of burnt brick, polymer-modified mortar and a pressed metal frame. Stofix brick panels are manufactured in standard sizes. The brick panels are measured and cut on site. Only corner elements need to be manufactured to size. Brick panels are suitable for both new buildings and reconstruction. Stofix brick panels allow for any number of colour combinations.

The Stofix mounting system has been developed for quick, smart and invisible mounting of various shapes of panel façade surface materials. The mounting system allows for thermal insulation and straightening of wall surfaces in both renovated buildings and new construction. Thanks to its modular character, the Stofix mounting system speeds up the construction project considerably.

2 Project Design

The following details should be considered in the project design:

- The recommended distance between the lower end of the cladding and the ground is 500 mm.
- Cavities must not be blocked with plating or anything else.
- The minimum cutting width of a brick panel is 200 mm. When cutting the panel, the row of vertical joints next to the cutting line should remain intact.
- Panels of less than 500 mm with no lateral bonding must have supports at both top and lower ends.
- In shock-sensitive areas, such as near exterior doors, we recommend horizontal rails with 300 mm spacing.
- Light accessories, such as lamps, can be attached directly to brick panels following separate installation instructions.
- In the installation of heavier accessories, such as fire ladders attached directly to the frame, separate instructions must be followed.

A separate diagram defining the types and sizes of different elements is drawn up for each project. As corner panels and box elements are manufactured to size, the construction method of external corners and window frames (straight bricks/corner bricks) must be defined before drawing up the diagram. Straight panels have a standard size of 1200 mm × 600 mm and have to be cut to size on site.

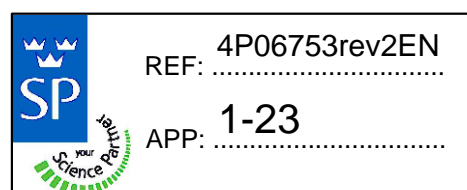

2.1 Technical Specifications

Façade Surface	Burnt Brick	Ceramic Tile
Panel dimensions	Standard brick panel: 285x85x20 mm, Special size of brick can be used.	Depends on the project
Joints	Cement-based, polymer-modified mortar	
Elasticity of joint mortar	4 %	
Joint surface material	Micro-stone (crushed stone)	
Jointing temperature	>+5 °C, curing time 3 days	
Frame	Hot-dip galvanized, 275–350 g/m ²	
Surface area of Stofix panels	0.72 m ²	0,50–0,91 m ²
– Height	600 mm	500–700 mm
– Width	1200 mm	1000–1300 mm
– Thickness	21 mm	15–20 mm
Weight	About 40 kg / m ²	About 20–50 kg / m ²
Surface panel Bonds	Standard 1/2 brick, 1/3 brick, unbonded. Special bond can be used.	Standard 1/2 tile, 1/3 tile, unbonded. Special bond can be used.
Thermal expansion	0,5 mm / m (from 20 °C to +50 °C)	
Minimum cavity	25 mm without insulation, 35 mm with insulation	
Expansion joints	At 7.5 m intervals when length / height exceeds 12m	
Additional insulation capacity	40–250 mm	
Wall brackets	Hot-dip galvanized, 275 g/m ² , thickness 2.0 mm	
Mounting rails	Hot-dip galvanized, 275–350 g/m ² , thickness 1.25 mm	

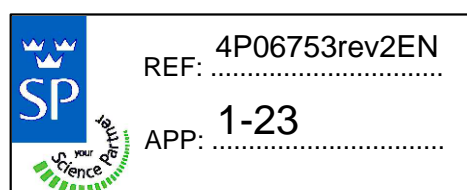

2.2 Exploded View

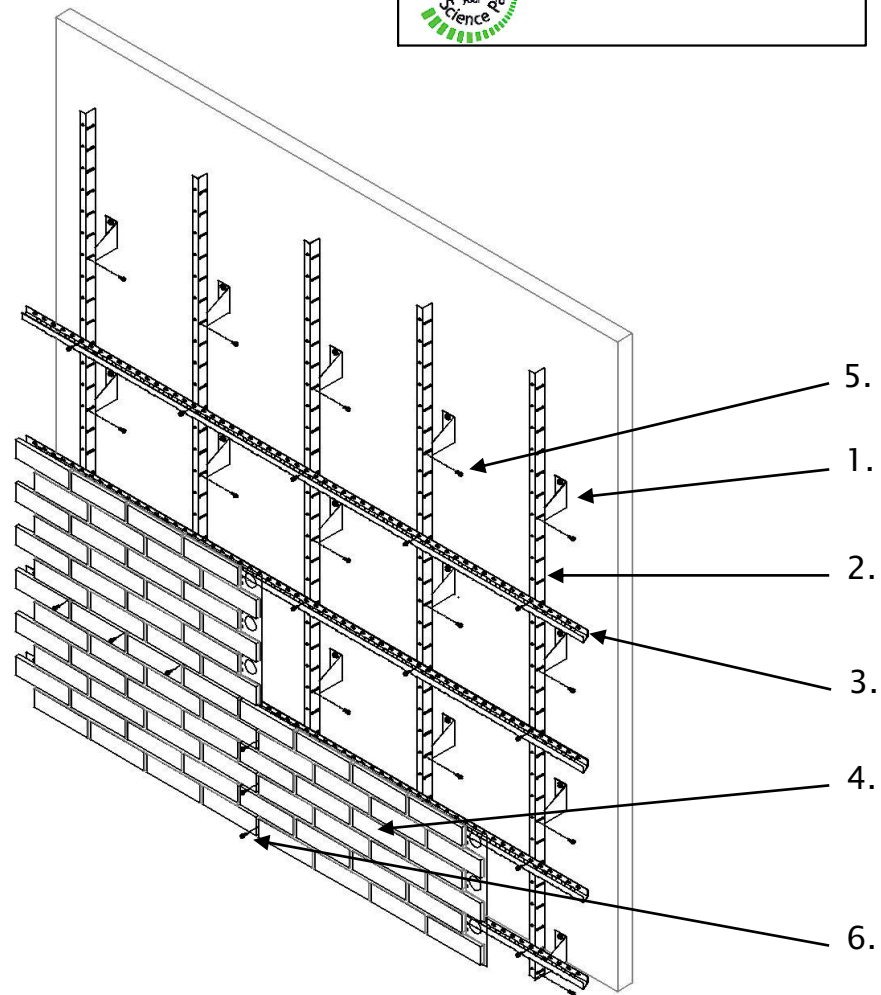
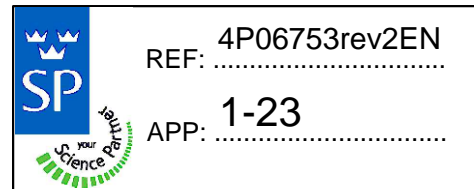

1. Wall brackets
2. Insulation rail
3. Mounting rail
4. Stofix brick panel
5. Hex socket screw
6. Self-drilling screws (for fixing the brick panels at joints before on-site sealing, six screws for each panel.)

2.3 Dimension Diagrams

2.3.1 Stofix Brick Panel

2.3.1.1 Straight Panel

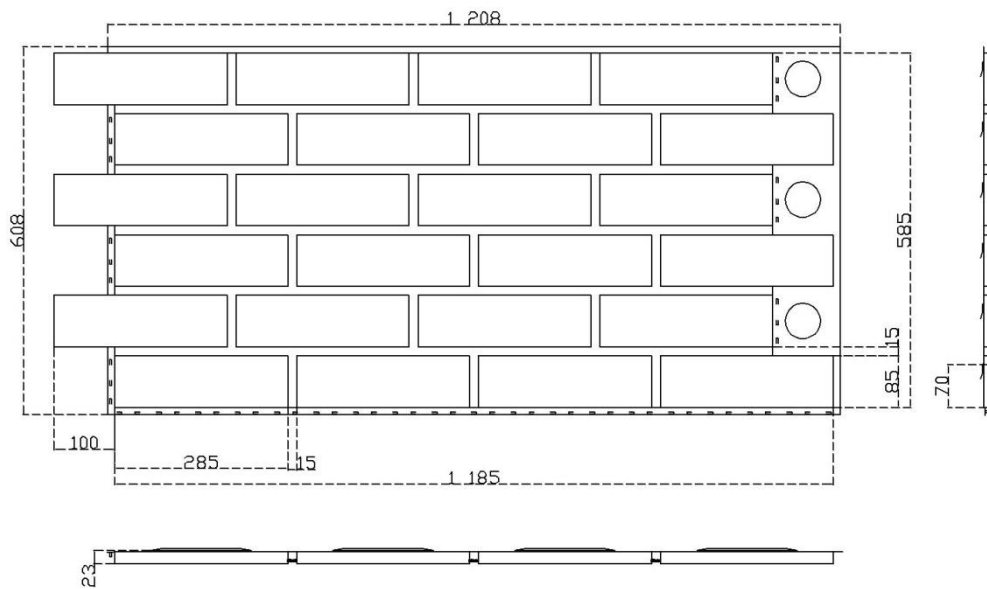
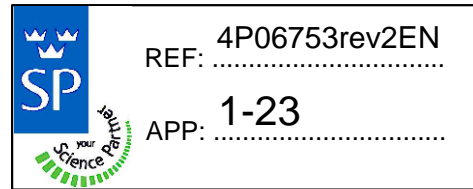

2.3.1.2 Left Corner Panel

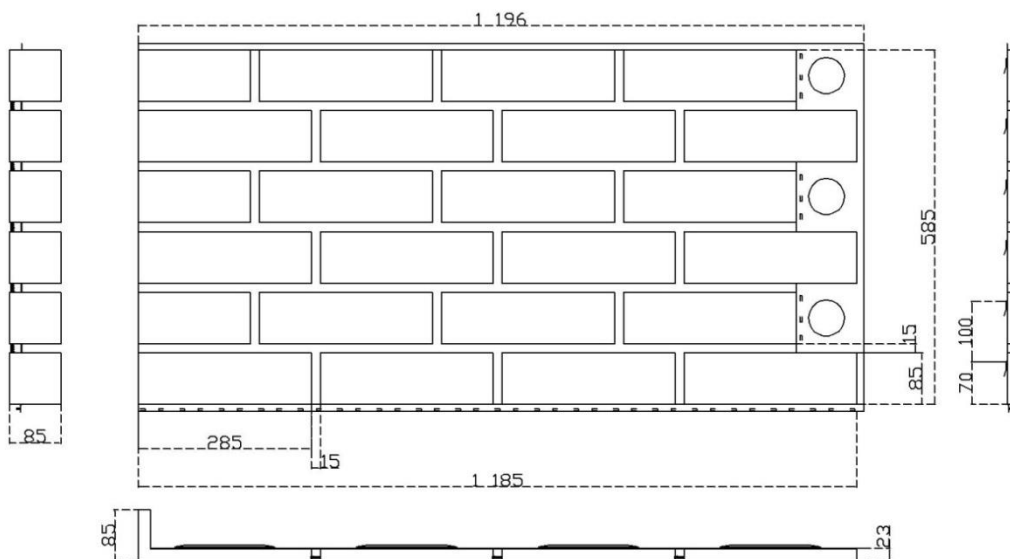

2.3.1.3 Right Corner Panel

 REF: 4P06753rev2EN
APP: 1-23

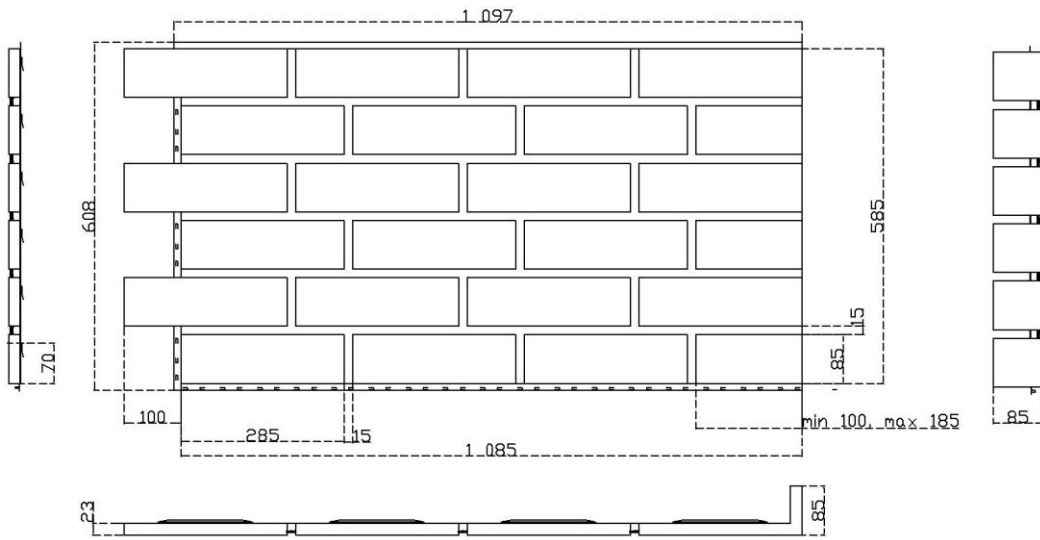

2.3.1.4 Box Element

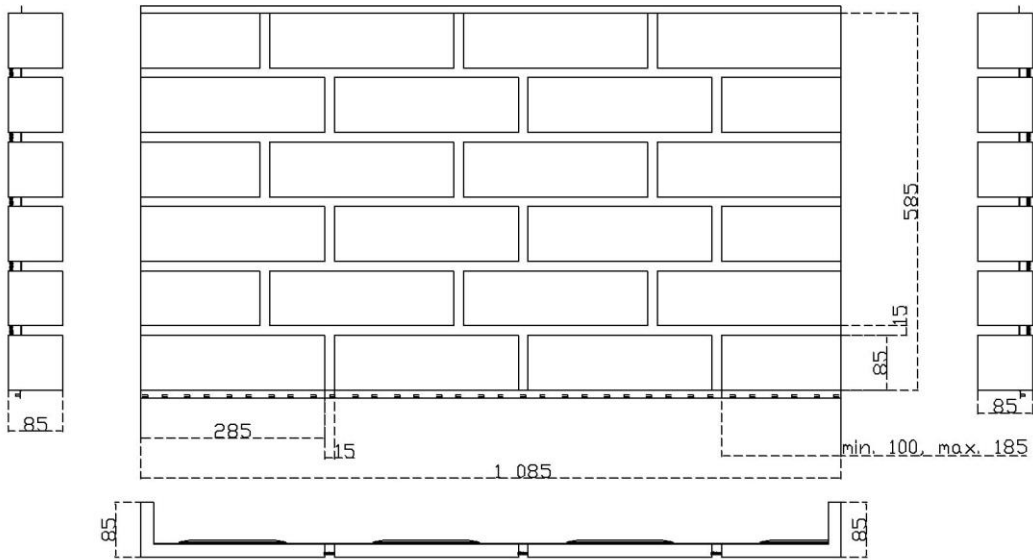

2.4 Stofix Mounting System

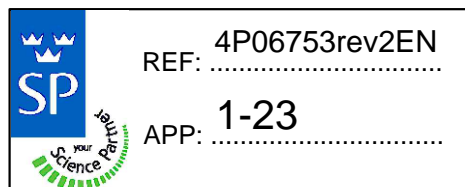
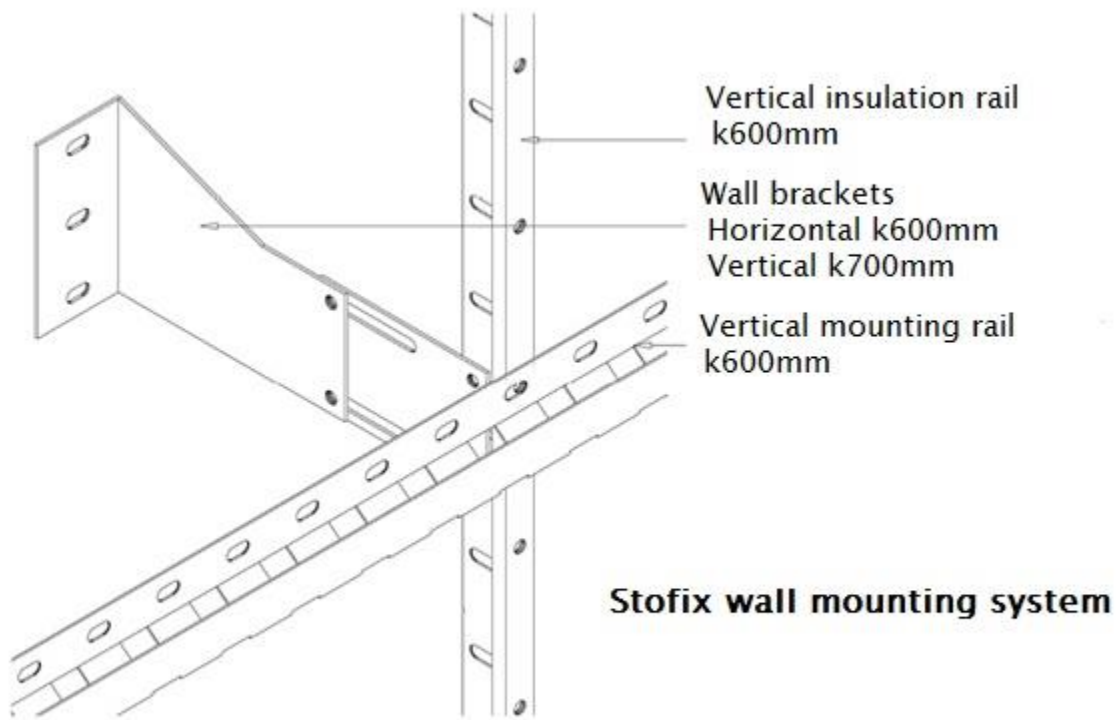

2.4.1 Mounting Rail

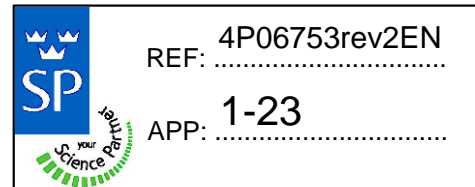
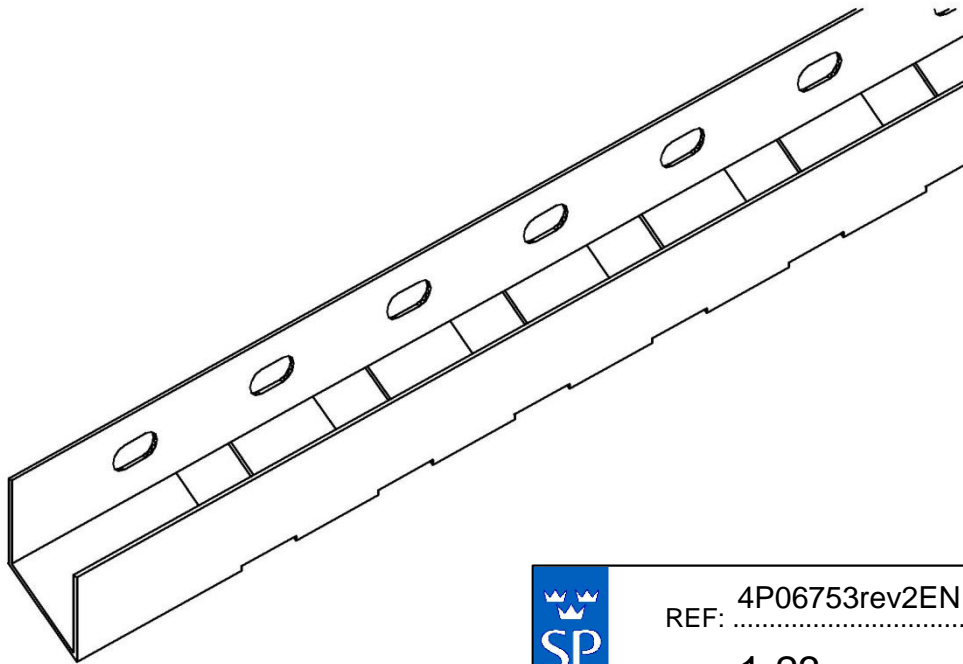

2.4.2 Insulation Rail



2.4.3 Mounting Brackets

~~2.4.3.1 Wall Bracket 65 (SK 65)~~

	REF: 4P06753rev2EN
	APP: 1-23

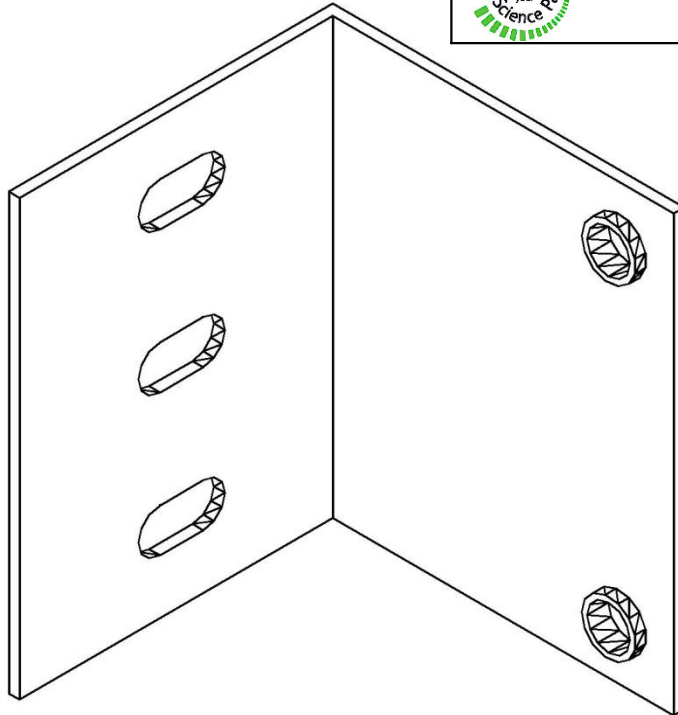

~~2.4.3.2 Wall Bracket 115 (SK 115)~~

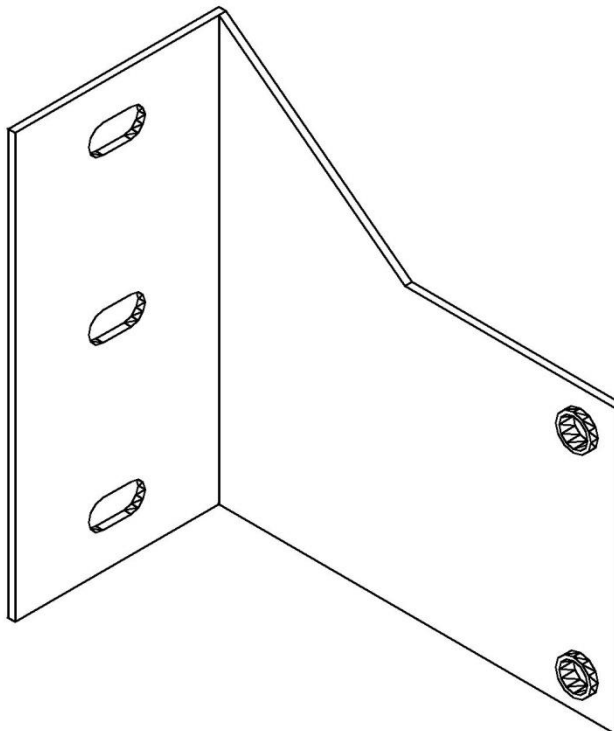

2.4.3.3 Mounting Bracket 165 (SK165)

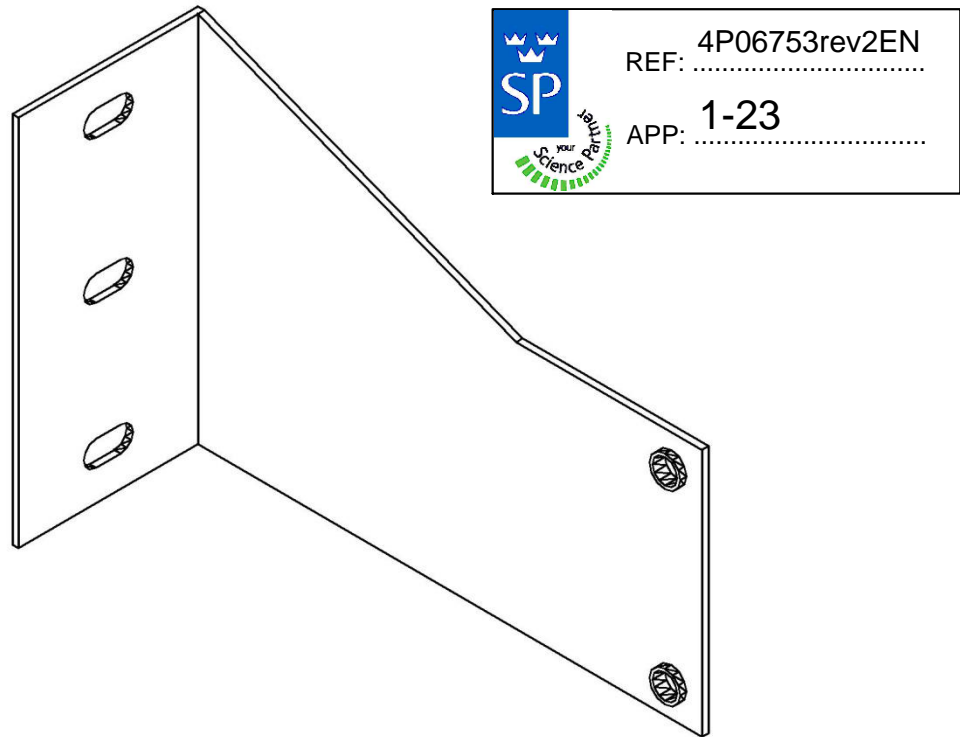

~~2.4.3.4 Extension Bracket 120 (JK 120)~~

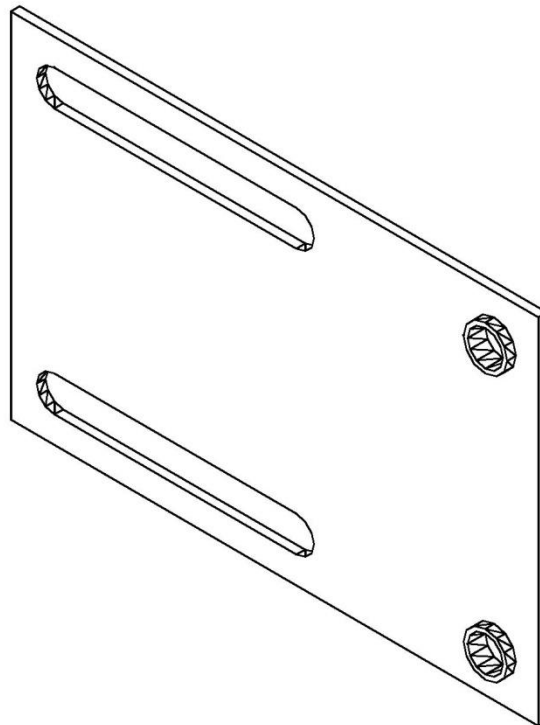

2.4.3.5 ~~Wall Bracket + Extension Bracket~~

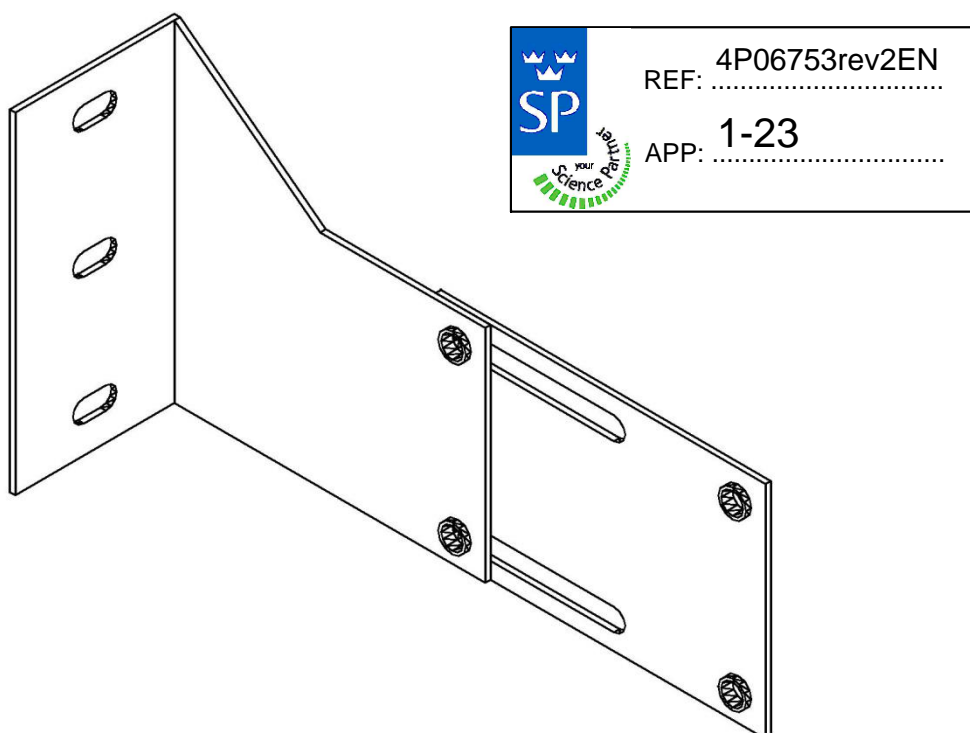

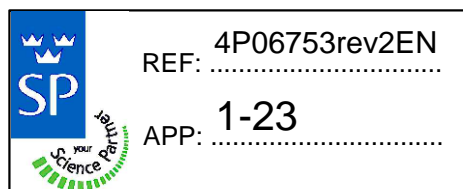

3 Installation

3.1 Preparation

Insulation panels and brick panels can be installed by using scaffolding or lifting equipment; always follow the applicable safety instructions.

Before you start, remove the following from the façade:

- Any equipment and accessories on the façade that will have to be reinstalled.
- Old drain pipes. Temporary spouts should be installed at the connections of the drainpipes of rain gutters.

External door and window lintels and windowsills should be removed and replaced with new ones.

3.2 Storage

Stofix brick panels are delivered on disposable pallets. The pallets are covered with plastic and tightened with a plastic strap. The pallets should be stored on a flat surface at an adequate distance from the constructed or renovated wall.

3.3 Installation of the Stofix Mounting System

3.3.1 Bottom Plate

Install the bottom plate according to the instructions provided by the structural engineer.

3.3.2 Wall Brackets

When installing the wall brackets, use a laser measuring device or a blumb-line to ensure that the wall brackets follow a straight line. Proceed from left to right and from bottom to top.

Install the lower edge of the first wall bracket as shown (97 mm above the desired bottom line of the brick panel.)

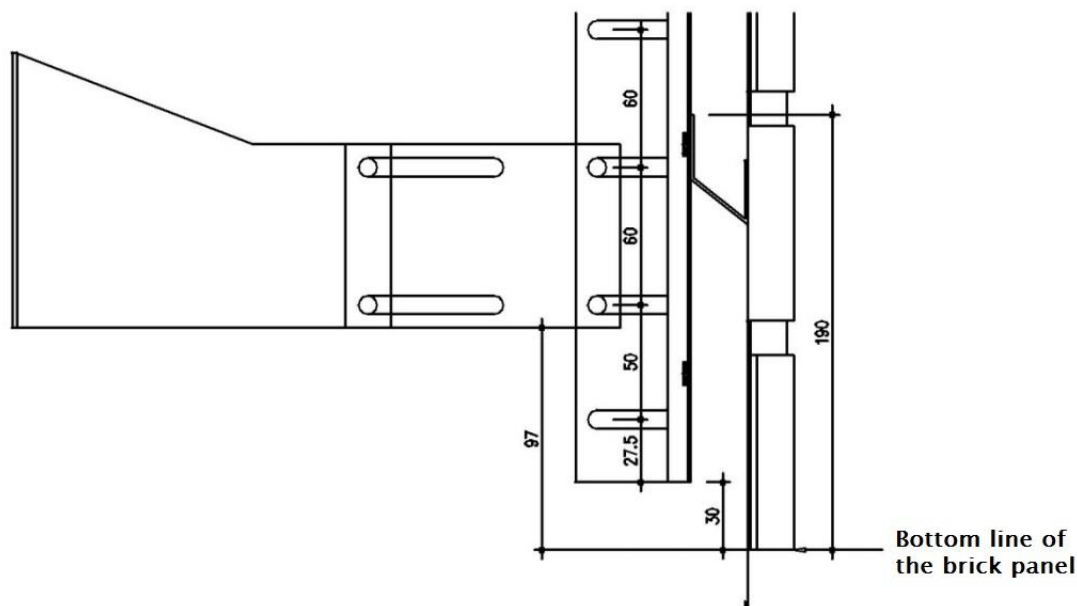

When starting from a corner the first wall bracket must be installed at a distance of about 300 mm from the future corner. Attach the next wall brackets horizontally with 600 mm spacing (this determines the horizontal straightness of the cladding).

The vertical spacing between brackets should be 700 mm. Here, an insulation rail is useful, as fixing the upper wall brackets straight to the insulation rail allows you to use the rail as a guide for installing the fixtures.

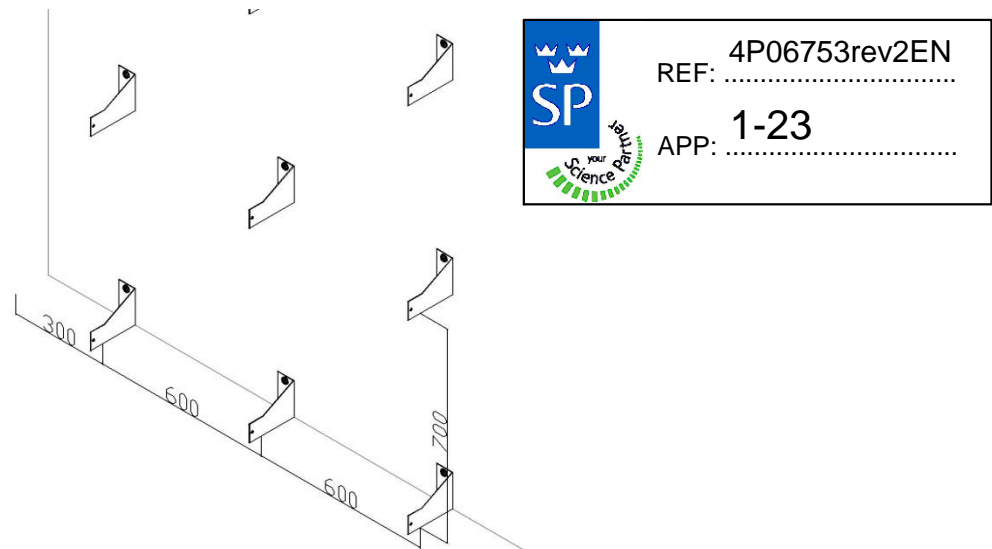

3.3.3 Ties to External Skin

Follow the instructions provided by the structural engineer when installing ties to the external skin. Below is an example of a project where the old external skin is covered with thermal insulation and Stofix brick panel cladding.

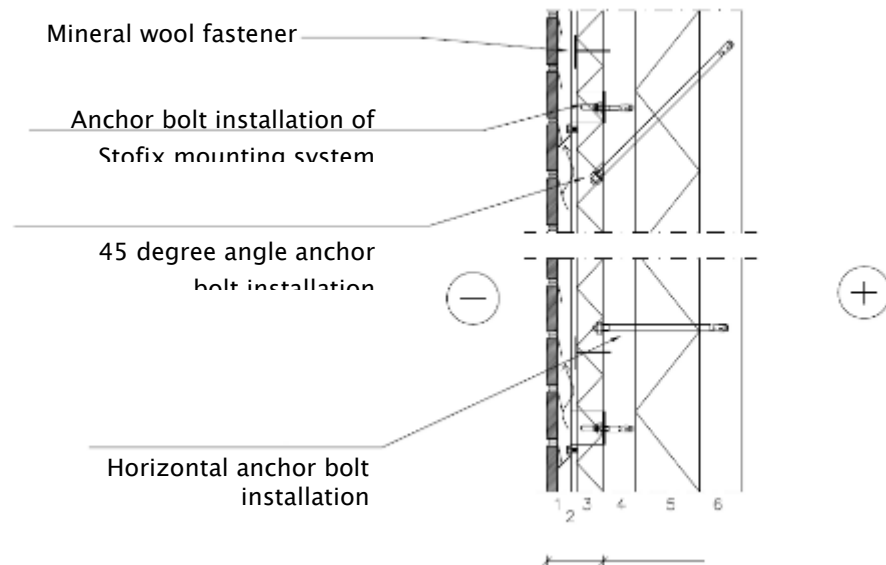

3.3.4 Installation and Adjustment of Insulation Rails

Attach the insulation rail to the fixtures with 8 mm hex socket screws. Adjust the rails and tighten the screws. Use a laser measuring device or a plumb-line in adjusting the rails.

3.3.5 Coupling Bracket

Coupling brackets are used for jointing vertical insulation rails. Coupling brackets replace wall brackets in junctions.

3.3.6 Insulation

Structural plans illustrate the type and thickness of thermal insulation layers. If the thickness of thermal insulation exceeds 50 mm, we recommend that the insulation in the bottom layer is installed horizontally and the top layer is installed vertically (overlapping of seams).

3.3.7 Installation of Mounting Rails

Attach the lowest mounting rail to the second holes from the bottom of the insulation rail with 8 mm hex socket screws.

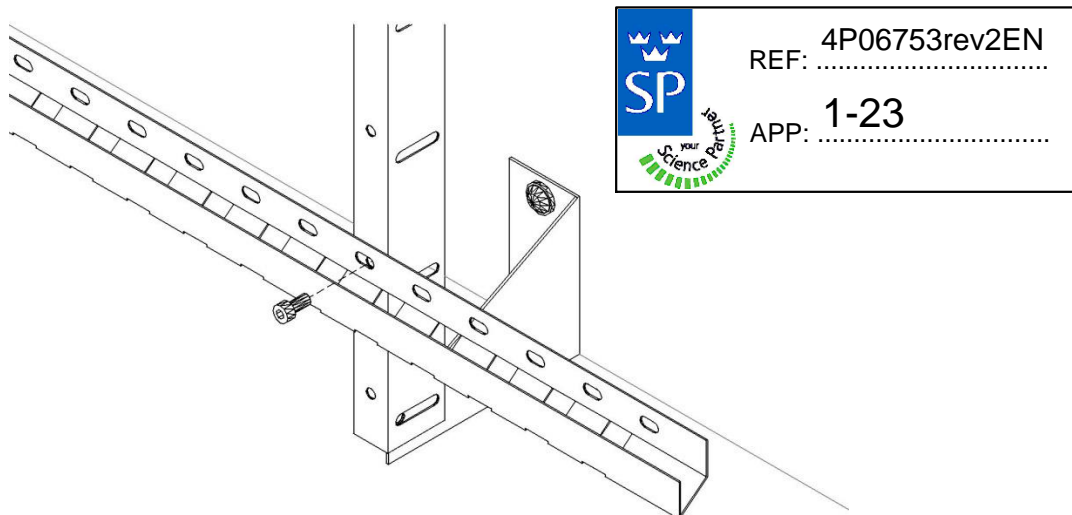

From bottom to top, the first spacing between rails is 400 mm and the next ones 600 mm.

If the vertical dimension of a brick panel has to be trimmed (below windows and other critical places), the mounting rail should always be fixed according to the actual dimensions of the cut brick panel.

In overlaps and horizontal expansion joints, the brick panels have to be supported at both top and lower ends. Here, the mounting rail should be fixed on the bottom attachment flange of the brick panel. In this case, the first spacing between rails is 500 mm and the next ones 600 mm.

The spacing between attachment flanges at the back of brick panels is 100 mm. See also Expansion joints.

3.3.8 Cutting

Insulation and mounting rails can be cut with snips.

3.4 Installation of Stofix Brick Cladding

3.4.1 Installation of Mounting Rails for Cladding with No Insulation

When installing cladding with no insulation, install the top end of the mounting rail 190 mm above the desired cladding bottom line.

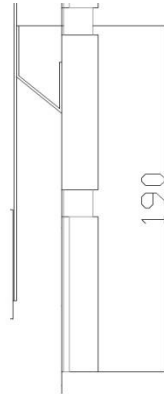

From bottom to top, the first spacing between rails is 400 mm and the next ones 600 mm.

If the vertical dimension of a brick panel has to be trimmed (below windows and other critical places), the mounting rail should always be fixed according to the actual dimensions of the cut brick panel.

In overlaps and horizontal expansion joints, the brick panels have to be supported at both top and lower ends. Here, the mounting rail should be fixed on the bottom attachment flange of the brick panel. In this case, the first spacing between rails is 500 mm and the next ones 600 mm.

The spacing between attachment flanges at the back of brick panels is 100 mm. See also Expansion joints.

3.4.2 Installation of Brick Panels

It should be ensured that the panel width at corners is at least 300 mm. Installation should be started at the bottom-left corner of the wall. When starting installation at a corner, cut off the unnecessary panel ends or use corner elements.

Lift the brick panels in the bottom row onto the mounting rail and ensure that the attachment flanges of the panel support the panel at both top and lower ends. This also applies to all overlaps and horizontal expansion joints, windows, doors, etc.

In the next row, the brick panels should be supported at their top ends.

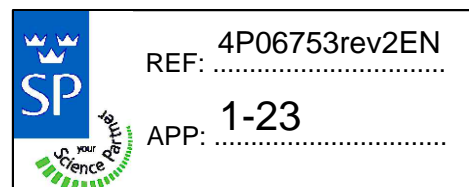

3.4.3 Coupling the Panels

The brick panels are coupled with the supplied self-drilling screws. There are three screws for each vertical and horizontal joint.

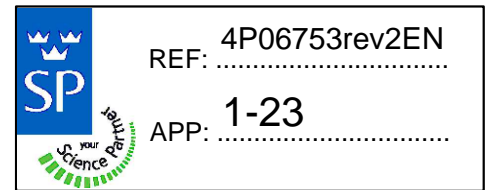
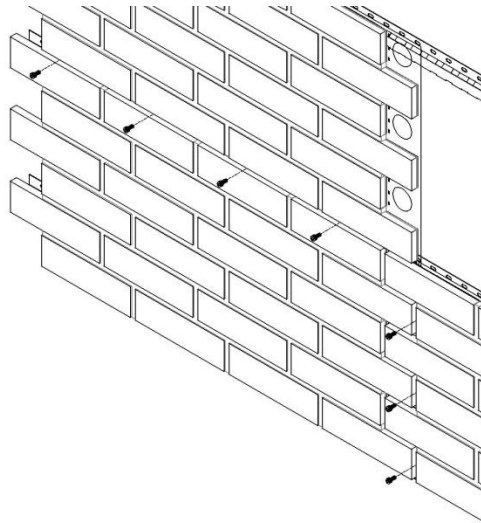

3.4.4 Cutting

Brick panels are cut with a diamond wheel. The frame at the back of brick panels is cut with a steel cutting disc. Near windows and doors, the vertical or horizontal dimension of a brick panel can be trimmed as necessary.

- Trim the panel with the brick surface outward.
- Draw the outline of the piece to be cut onto the brick panel.
- Place the guide at the outline.
- Cut the panel with the help of the guide.

If a straight vertical joint is to be used in corners, the frame of the brick panel to be installed in line with the corner should be cut off at a distance of about 25 mm from the edge. In this case, start cutting from the back of the brick plate. Wear eye and ear protection when cutting the panels. Consider your own safety as well as that of your environment.

3.4.5 Grouting the Joints on Site

Mix the grout with a mixing whisk following the supplied instructions.

Mix with a mixing whisk for about two minutes, let the grout stand for about five minutes and continue mixing for about 30 seconds. Apply the grout with an extruder gun into the open joints between the panels so that the surface of the grout is 3–4 mm below the surface of the brick plate. Smooth the surface of the wet joint with a grout rake so that the surface is level to the factory joint. Apply the crushed stone on a wet surface at a distance of about 30 cm using as little pressure as possible.

3.4.6 Expansion Joints

The minimum spacing between expansion joints is 7.5 m if the height/width of the wall exceeds 12 m (in other words, a wall of 12 m × 12 m or less does not need expansion joints).

Press a strong 20 mm cellular rubber band into the bottom of the joint and apply the filling paste specified by the designer on top of the band. Finish the surface of the joint with a grout rake.

To make the expansion joint the same colour as other joints, it is also possible to apply the supplied crushed stone to the surface of the joint.

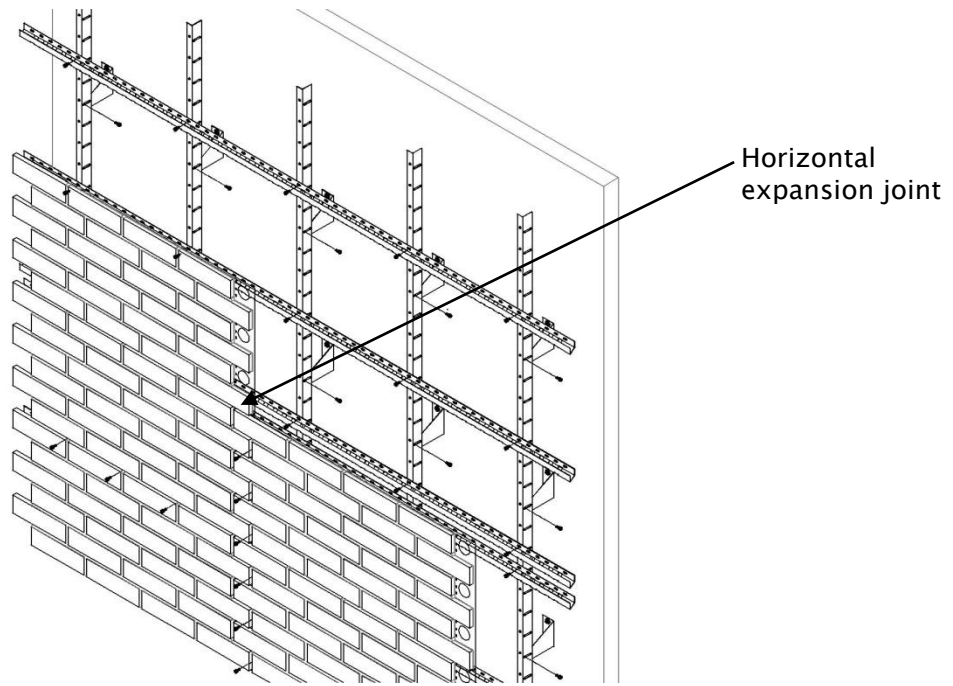

The above figure illustrates a horizontal expansion joint (with no self-drilling screws and a different spacing between mounting rails).

	REF: 4P06753rev2EN
	APP: 1-23

First spacing between horizontal rails after horizontal expansion joint 500mm. Subsequent spacings 600mm.

Spacing between horizontal expansion joint and first horizontal rail 100mm.

Panels are not coupled on expansion joints.

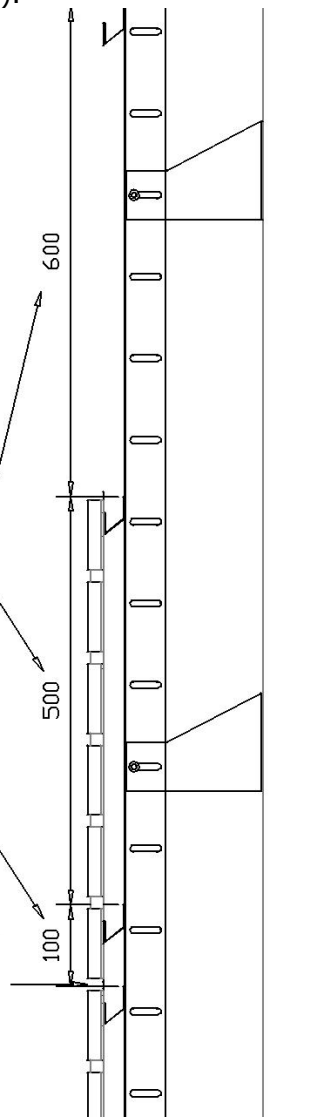

The figure illustrates the spacing between horizontal rails after a horizontal expansion joint.

3.4.7 Flashings

Flashings should be installed with special care. For detailed installation instructions, see structural diagrams. Windowsills should be installed in the groove at the frame of the window.

3.4.8 Finishing

Replace the lamps, plates, sensors, wiring and other accessories according to the installation instruction.

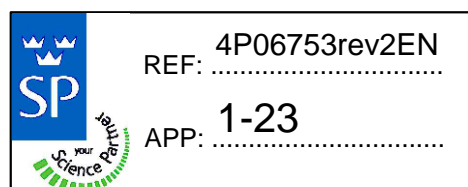

4 Instructions for Installing Hardware on Stofix Brick Panel Walls

4.1 Lightweight Structures

Lightweight structures of less than 10 kg, such as lamps, plates, sensors, wiring, etc., can be installed directly on the Stonel brick wall with metal anchors (Illustrated below).

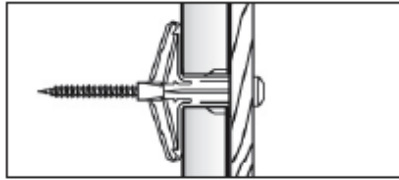

4.2 Heavy Structures

Heavy fixed structures with a weight of more than 10 kg should be installed through the Stofix plates on the load-bearing frame or, in some cases, on the Stofix mounting system. In this case, the hole to be cut through the brick cladding should be large enough to allow potential movement of the structure without damaging the cladding (see illustration below).

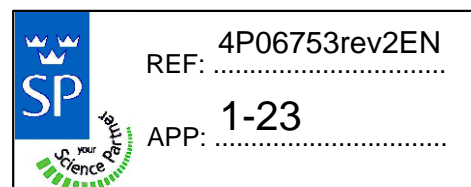
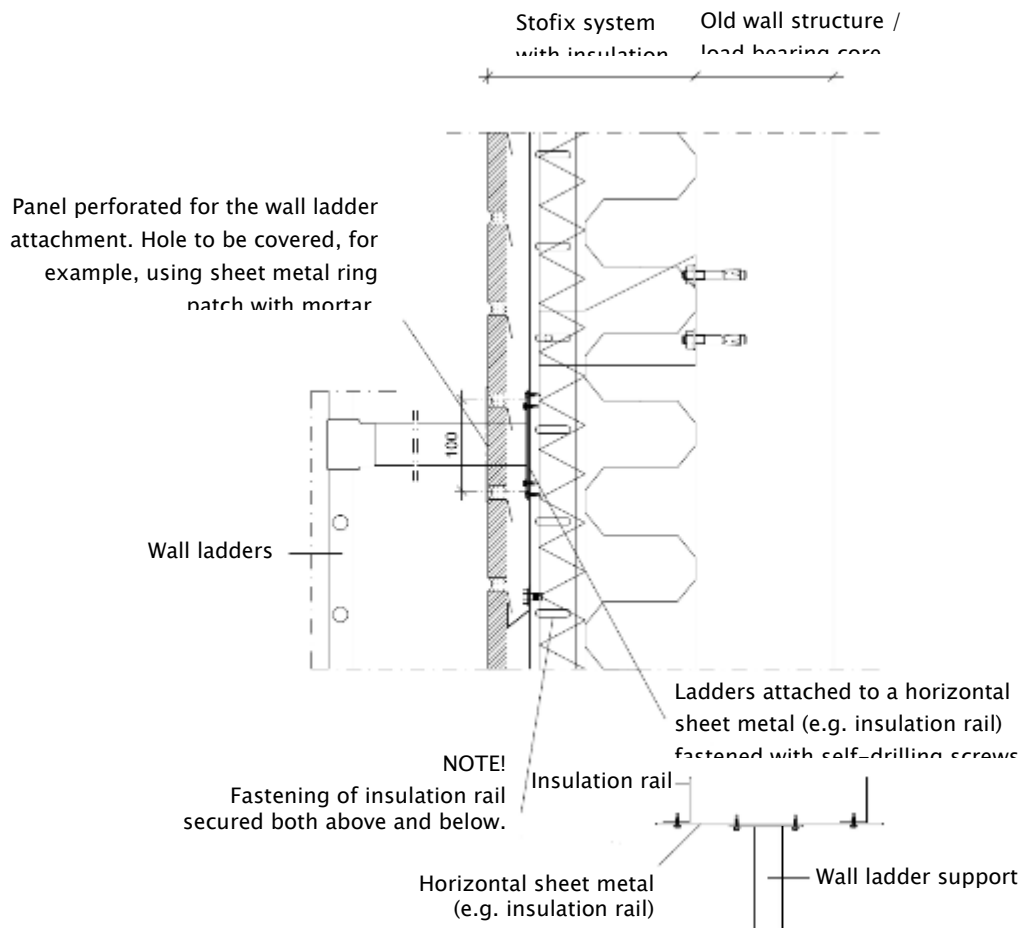

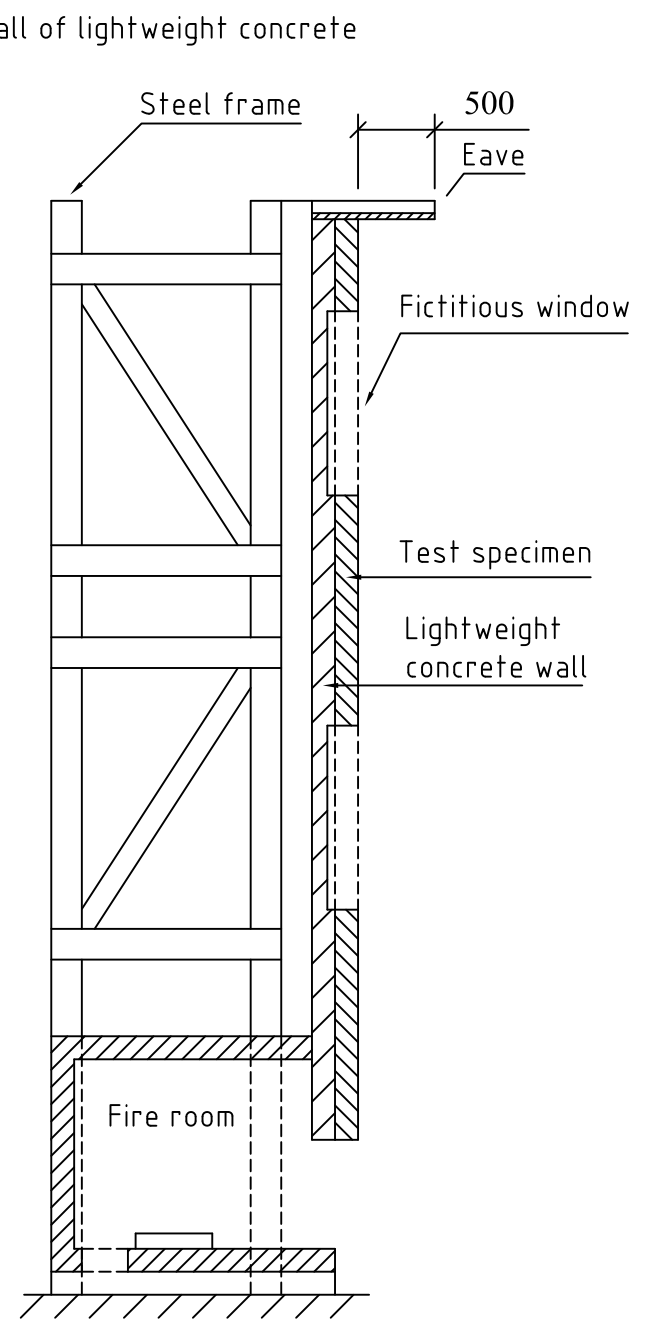
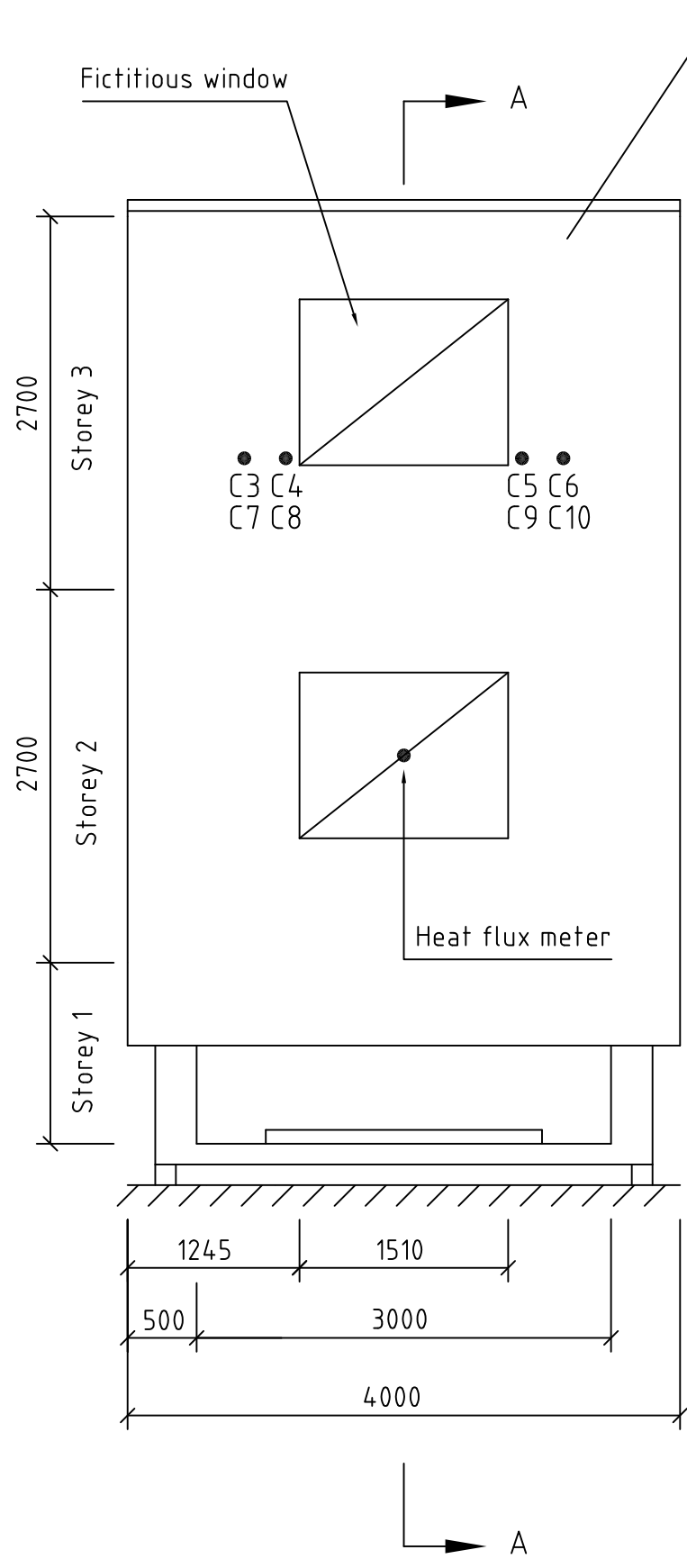

Mounting of facade cladding system on test rig

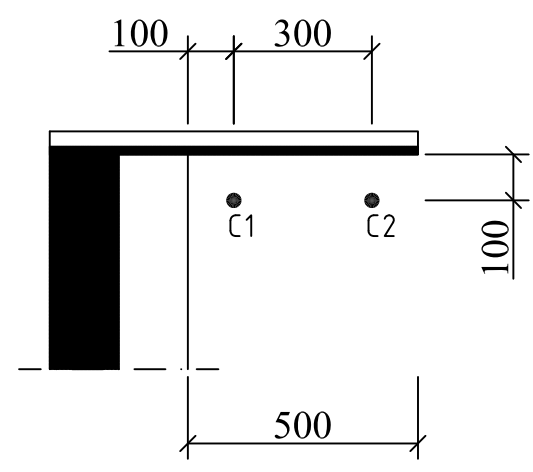
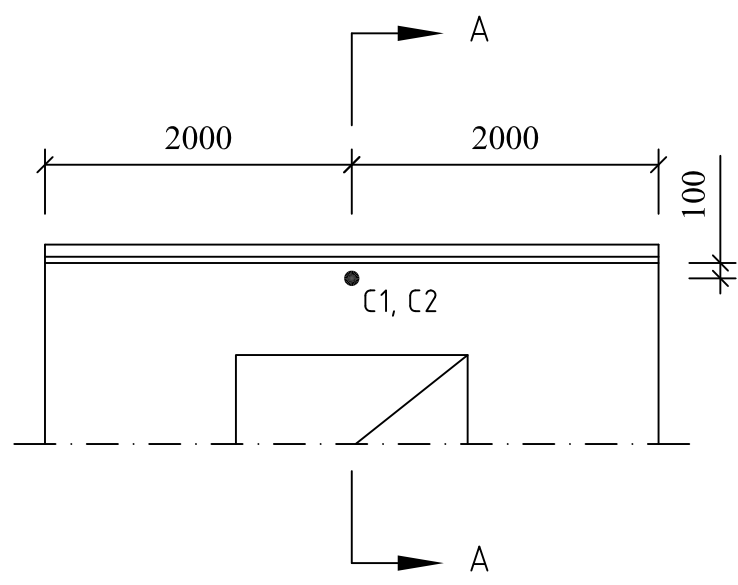

Section A-A

Thermocouple C1-C2



Temperature at the eave

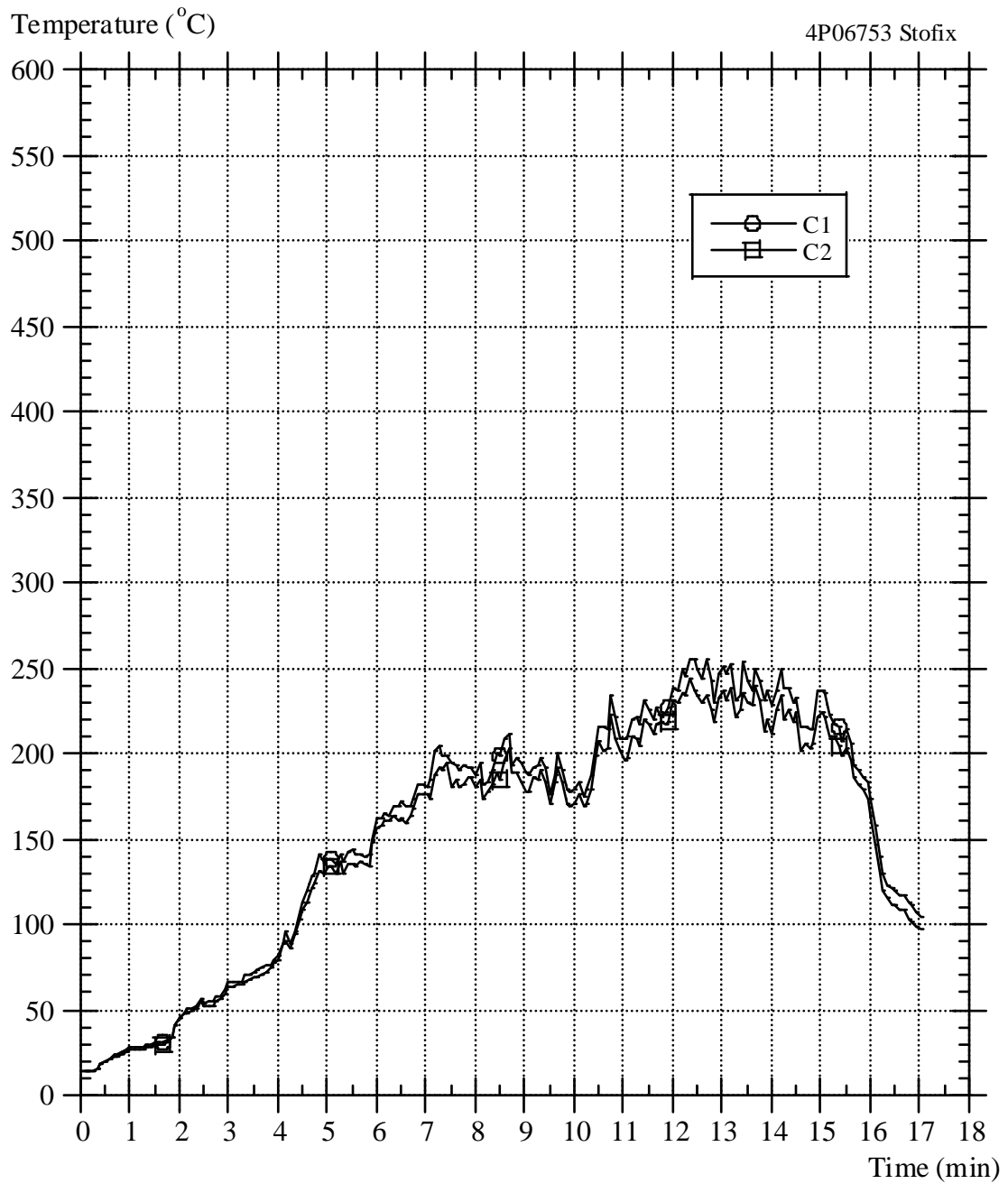



Extra temperature measurements

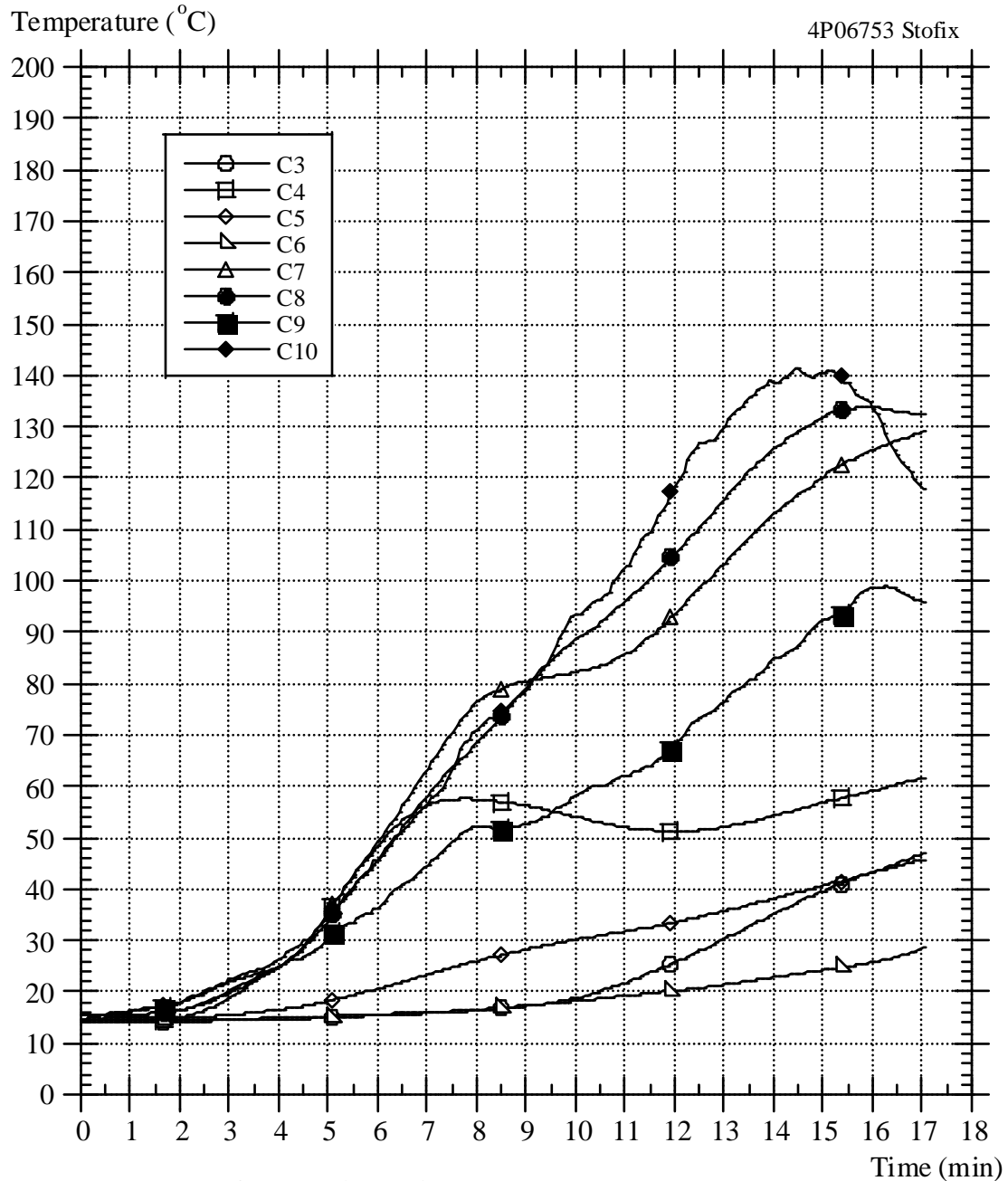

Placement of measuring points:

C3-C6 between the insulation layers

C7-C10 on the outermost layer insulation



Heat flux at the lower fictitious window

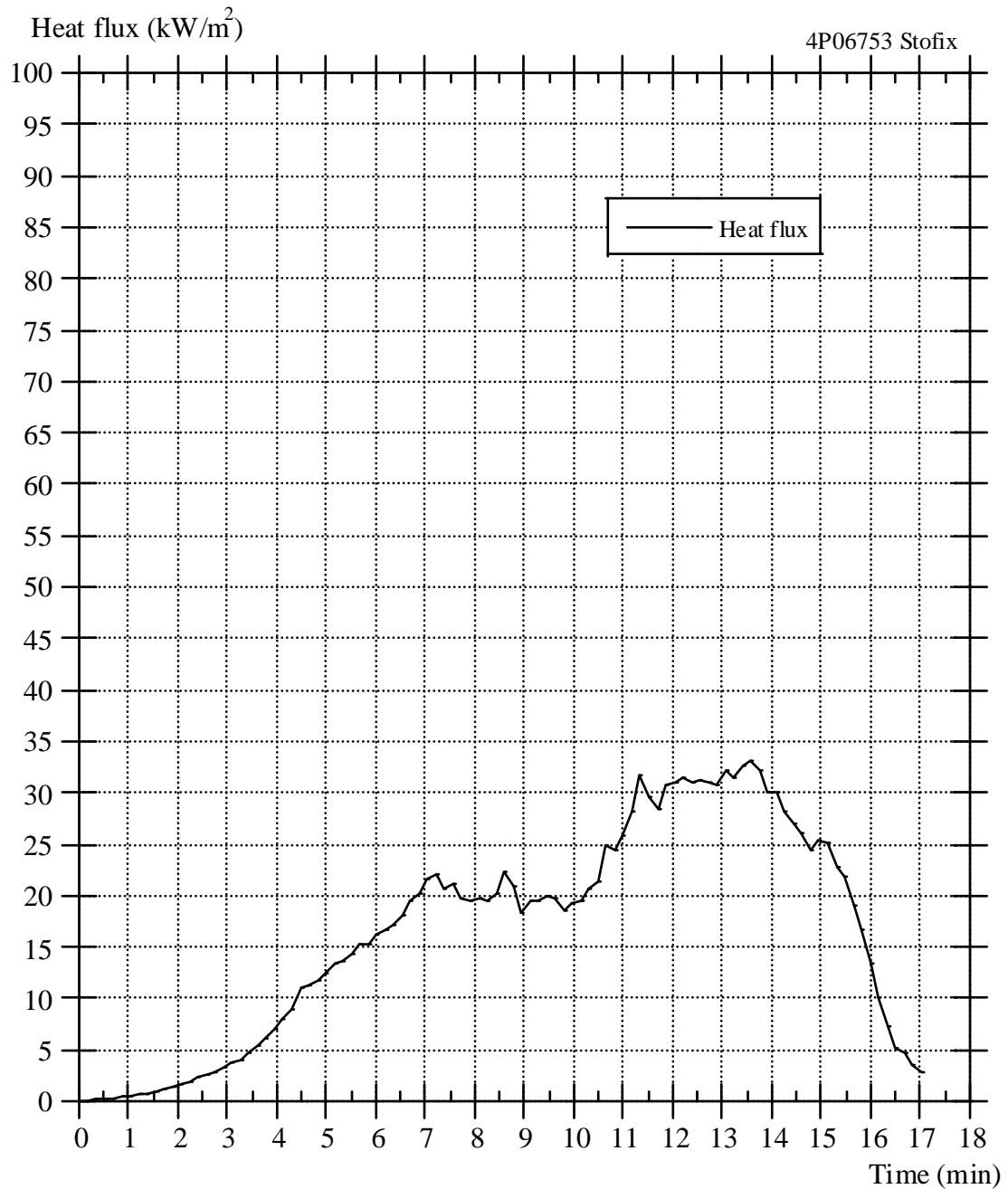

Appendix: 29

Report: 4P06753rev2EN

Photo No: 1

The test specimen at the beginning of the test.

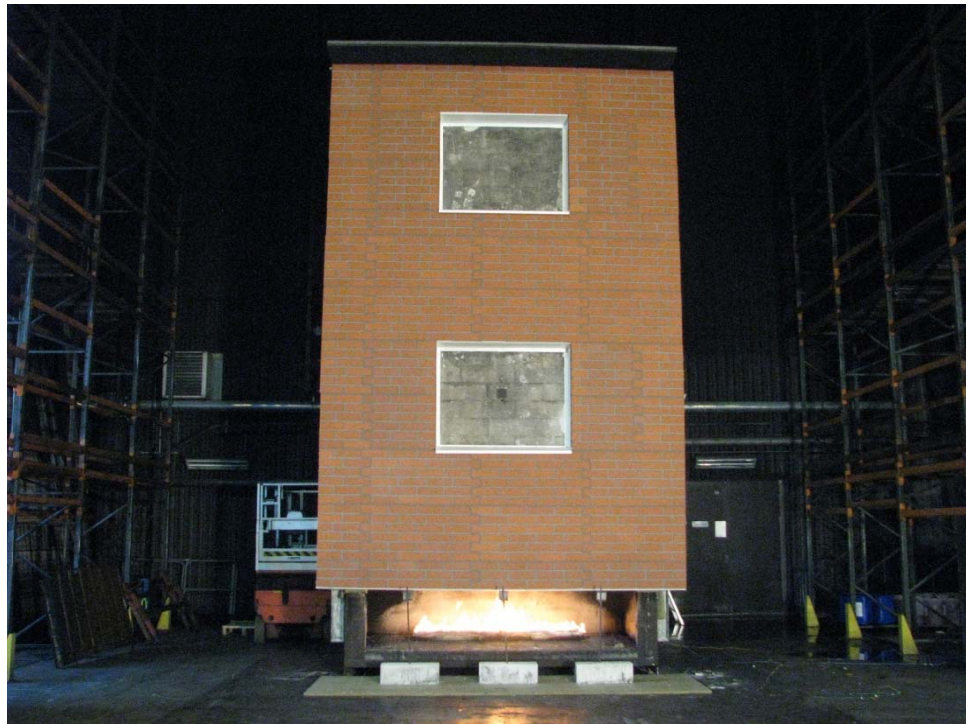

Photo No: 2

The test specimen after the test.

The test specimen has been extinguished with water.





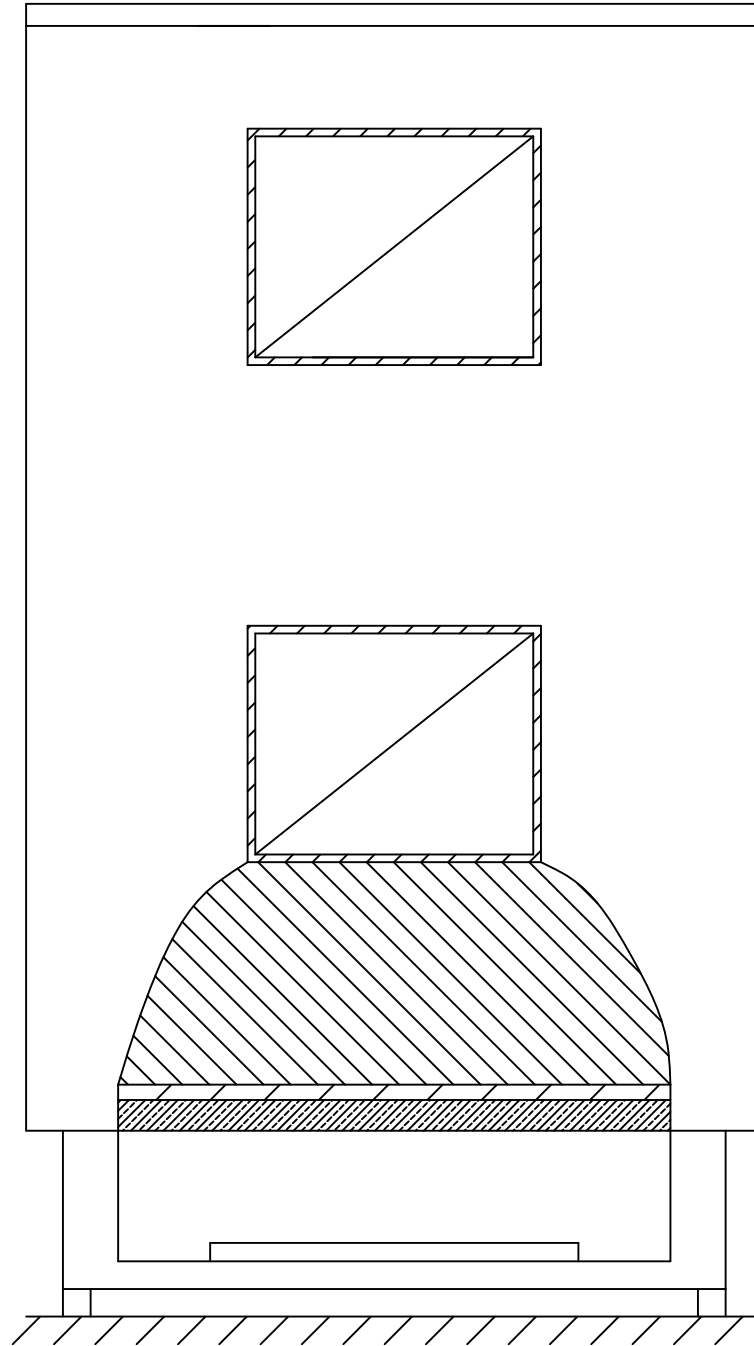

Photo No: 3

The test specimen after the test.





-  The insulation is undamaged
-  The PIR insulation is discoloured
-  The Västkustskivan (mineral wool insulation) is discoloured
-  The PIR insulation is charred 1-2 cm
-  The PIR insulation (10 cm) and the Västkustskiva (mineral wool insulation) (2-3 cm) are charred