

NORTHGATE
TAKING CARE OF EVERY ASPECT



SUBRA GRILLE

NORTHGATE
TAKING CARE OF EVERY ASPECT

Northgate, PO Box 200, Barnet, Herts EN4 9EW
Tel 020 8441 4545 **Fax** 020 8441 4888
Website www.northgateuk.com **Email** enquiries@northgateuk.com

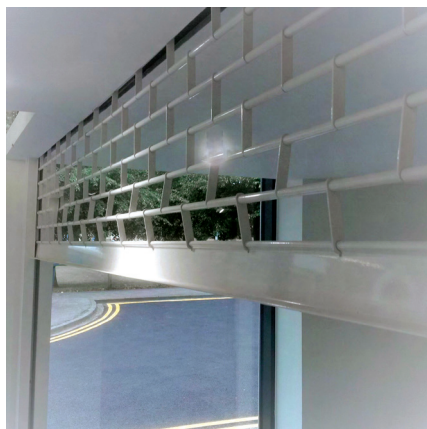

SUBRA GRILLE

Medium security commercial sites where see-through vision is a priority. The Steelroll Tube & Link Grille offers high visibility and can be used internally behind glass for shop displays, or as a stand-alone security barrier. The Tube & Link Grille is also available with aluminium housing, see Steelroll Tube & Link Grille with Aluminium Housing.

Grille lattice

Brick-bond effect or standard arrangement.

Aluminium 13mm diameter tubes cut to 111mm as standard, with anodised finish, enclosing an 8mm steel rod.

Vertical lattice links are 86mm high, leaving 56mm high openings; smaller or larger apertures on request.

Colours: Anodised finish as standard.

Powder coating available.

Tube Length: 111mm

Link Height: 86mm

Weight per m²: 10kg

Maximum Width: 6,000mm

Maximum Surface: 24m² with single phase power or 3-phase power.

Enclosure/Housing

Steel variant: steel plate housing from 1.0mm steel: 3mm+ laser-cut and galvanised end caps.

Colours: Anodised finish as standard.

Powder coating available.

Guide Length (up to mm): Box Size (mm):

2200	300
3600	360
5500	400

3-phase motor applications enclosure sizes dependent on the overall shutter size.

Note: The above enclosure sizes are based on standard tube motor operation.

Guide Channels/Bottom Slat:

65mm galvanised guide sections are standard for the steel variant. Standard guide channel is 65x30mm, attached to either box or angle sections (see drawings to the right).

Colours: Anodised finish as standard.

Powder coating available.

Operation:

Electric: Single phase tubular motor or outboard direct drive motor dependent on intended application, with push button or key switch control. Remote control operation is available, and includes Optical Safety Edge, a PEC beam may also be appropriate with using remote control operation. Manual override facility as required. Safety brake included as standard, to meet requirements of BS EN 13241:2003-1.

Front face view

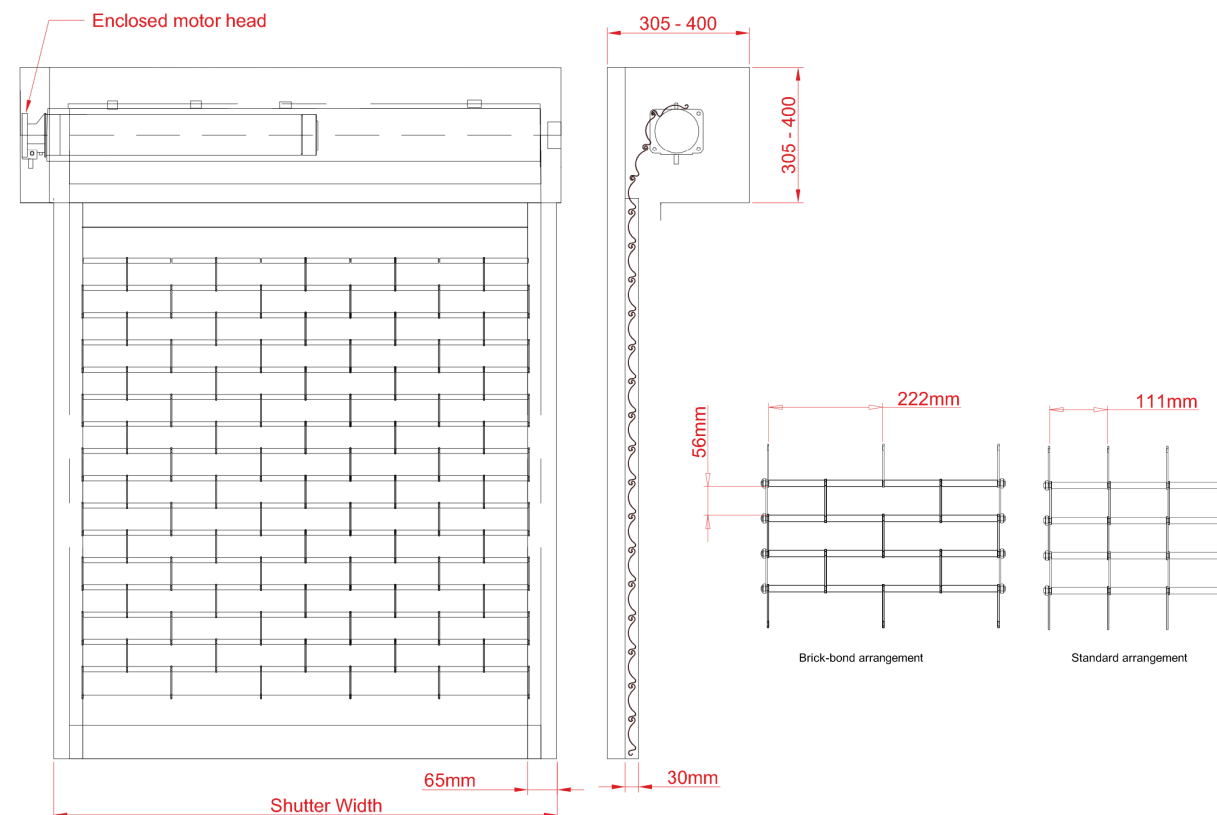

Fixing options

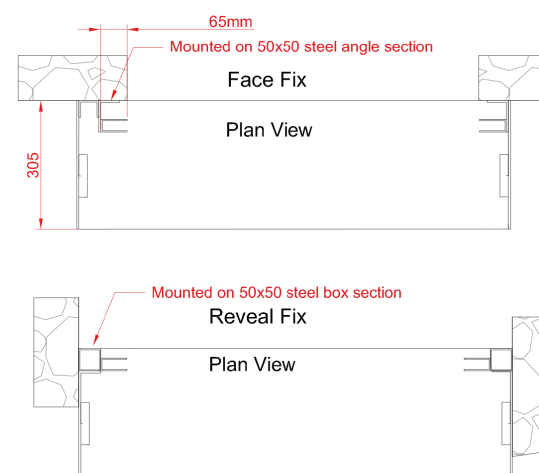

Guide options

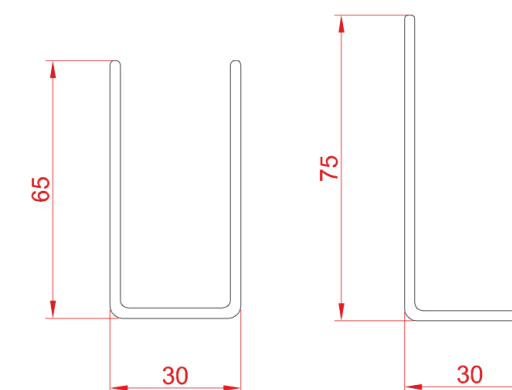

For more information and images please visit our website at:

WWW.NORTHGATEUK.COM/PRODUCT/SUBRA-GRILLE/