

Specifications

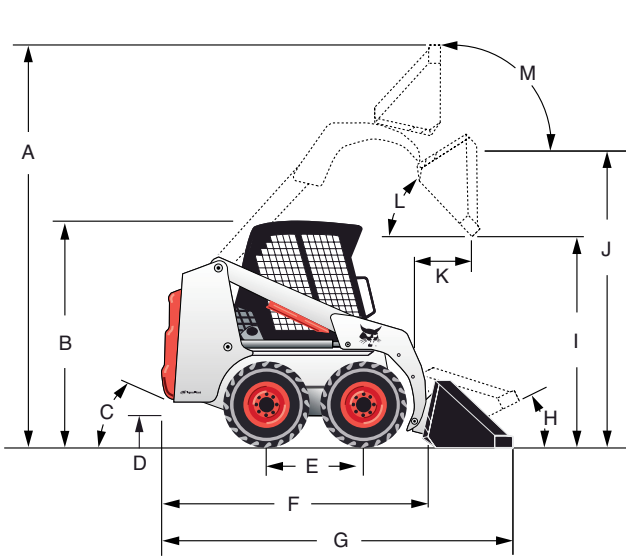

Radius lift path: S130, S150, S160H

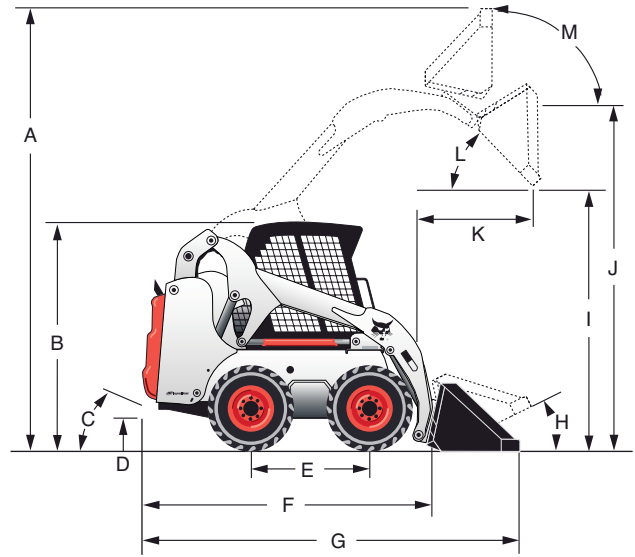

Vertical lift path: S175(H), S185H, S205(H)

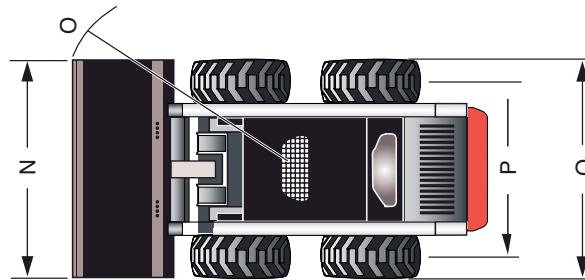

	S130	S150	S160H	S175/S175H	S185H	S205/S205H
A	3543	3759	3759	3862	3862	3862
B	1964	1938	1938	1938	1938	1938
C	23°	23°	23°	23°	23°	23°
D	188	191	191	191	191	191
E	900	1030	1030	1030	1030	1030
F	2432	2586	2586	2588	2588	2588
G	3152	3310	3310	3309	3309	3309
H	25°	25°	25°	25°	25°	25°
I	2100	2197	2197	2310	2310	2310
J	2781	2908	2908	3002	3002	3002
K	575	461	461	753	753	753
L	40°	44°	44°	42°	42°	42°
M	96°	92°	92°	95°	95°	95°
N	1575	1727	1727	1727	1727	1727
O	1745	2166	2166	2001	2001	2001
P	1165	1385	1385	1385	1385	1382
Q	1490	1676	1676	1676	1676	1676

Machine rating	S130	S150	S160H	S175/S175H	S185H	S205/S205H
Rated Operating Capacity (ROC)	590 kg	680 kg	726 kg	794 kg	840 kg	930 kg
Tipping Load	1195 kg	1407 kg	1497 kg	1872 kg	1849 kg	2019 kg
Pump capacity	64 l/min	64 l/min	100 l/min	64 l/min / 100 l/min	100 l/min	62 l/min / 96.5 l/min
High Flow hydraulics	-	-	Std	Opt / Std	Std	Opt / Std
System pressure	18.3 - 19.0 MPa	22.4 —23.1 MPa	22.4-23.1 MPa	22.4-23.1 MPa	22.4-23.1 MPa	22.4-23.1 MPa
Travel speed	11.8 km/h	11.3 km/h	11.8 km/h	11.8 km/h	11.8 km/h	11.75 km/h
Operating weight	2465 kg	2692 kg	2774 kg	2853 kg / 2873 kg	2821 kg	3023 kg / 3053 kg
Shipping weight	2128 kg	2327 kg	2409 kg	2488 kg	2456 kg	2658 kg

Engine

Engine Kubota / Model	V2203-M-DI-E2B-BC-3	V2003-M-DI-E2B-BC-3	V2003-M-DI-TE28-BC-3 T	V2003-M-DI-E28-BC-3	V2003-M-DI-TE28-BC-3 T	V2403-M-DI-T
Fuel / Cooling	Diesel / Liquid	Diesel / Liquid	Diesel / Liquid	Diesel / Liquid	Diesel / Liquid	Diesel / Liquid
Type	Naturally aspirated	Naturally aspirated	Turbo	Naturally aspirated	Turbo	Turbo
Maximum power at RPM (ISO 9249)	34.3 kW / 2800	34.3 kW / 2800	41.8 kW / 2800	34.3 kW / 2800	41.8 kW / 2800	45.5 kW / 2700
Torque at RPM (SAE J1 995)	150 Nm / 1700	150 Nm / 1700	169 Nm / 1825	145 Nm / 1700	169.5 Nm / 1825	218 Nm / 1475
Number of cylinders / Displacement	4 / 2196 cm ³	4 / 2196 cm ³	4 / 1999 cm ³	4 / 2196 cm ³	4 / 1999 cm ³	4 / 2433 cm ³
Fuel tank capacity	50.3 l	90.8 l	90.8 l	90.8 l	90.8 l	90.8 l

Control options

Bobcat Std (foot pedals / steering levers)	Std	Std	Std	Std	Std	Std
Advanced Control System (ACS)	Opt	Opt	Opt	Opt	Opt	Opt
Selectable Joystick Controls (SJC)	—	Opt	Opt	Opt	Opt	Opt

Tyres

Standard duty 10 x 16.5 — 8-ply	Std	—	—	—	—	—
Heavy duty 10 x 16.5 — 10-ply	Opt	Std	Std	Std	Std	—
Heavy duty with offset rims 10 x 16.5 — 10-ply	Opt	Opt	Opt	Opt	Opt	—
Super float 31.5 x 13 - 16.5 — 10-ply	Opt	Opt	Opt	Opt	Opt	Std
Severe duty 10 x 16.5 — 10-ply	Opt	Opt	Opt	Opt	Opt	—
Severe duty poly filled 10 x 16.5 — 10-ply	Opt	Opt	Opt	Opt	Opt	—
Segmented 10 - 16.5	Opt	Opt	Opt	Opt	Opt	—
Segmented — industrial type 7.50 - 15	Opt	Opt	Opt	Opt	Opt	—

Machine features

Bob-Tach™ — mechanical coupler	Std	Std	Std	Std	Std	Std
Power Bob-Tach™ — hydraulic coupler	Opt	Opt	Opt	Opt	Opt	Opt
Operating lights, front and rear	Std	Std	Std	Std	Std	Std
Bobcat Interlock Control System (BICS)	Std	Std	Std	Std	Std	Std
Deluxe operator cab*	Std	Std	Std	Std	Std	Std
Cab enclosure with heat	Opt	Opt	Opt	Opt	Opt	Opt
Cab enclosure with heat and air conditioning	—	—	Opt	—	Opt	Opt
Deluxe instrument panel	Opt	Opt	Opt	Opt	Opt	Opt
Pressure release hyd. quick couplers	Std	Std	Std	Std	Std	Std
Fingertip auxiliary control	Std	Std	Std	Std	Std	Std
CE certification	Std	Std	Std	Std	Std	Std
Warranty: 12 months or 2000 hours	Std	Std	Std	Std	Std	Std

* Roll Over Protective Structure (ROPS) - meets requirements of SAE-J1040 and ISO 3471; Falling Object Protective Structure (FOPS) - meets requirements of SAE-J1043 and ISO 3449, Level I*.

Attachments

Attachments	Angle (snow) blade, Angle broom, Auger, Backhoe, Box blade, Brushcat, Buckets, Bucket adapter, Chipper, Combination bucket, Digger, Dozer blade, Drop hammer, Dumper, Flail cutter, Grader, Hydraulic breaker, Indus bkt grapple, Indus fork grapple, Landplane, Landscape rake, Mixing bucket, Mower, Pallet forks, Planer, Rear stabiliser, Salt and sand spreader, Scarifier, Scraper, Snow V-blade, Snow blower, Sod layer, Soil conditioner, Stump grinder, Sweeper, Three-point hitch, Tiller, Tilt-Tatch™, Tracks (steel), Trench compactor, Trencher, Utility forks, Utility frame, Utility grapple, Vibratory roller, Water kit, Wheel saw, Whisker broom
-------------	--