

**ENGLISH****CAUTION!**

Inappropriate installation may cause injury to persons and damage to the lamp.

**DEUTSCH****VORSICHT!**

UnsachgemäÙe Installation kann zu Personen- und Sachschäden führen.

**NEDERLANDS****LET OP!**

Onjuiste installatie kan schade aan personen of de lamp veroorzaken.

**PORTUGUÊS****ATENÇÃO!**

A instalaçãoo inapropriada pode causar danos na luminária e ferimentos nas pessoas.

**ESPAÑOL****PELIGRO!**

Una instalación inadecuada puede provocar lesiones o dañar la lámpara.

**VLAAMS****LET OP!**

Verkeerde aansluiting kan schade veroorzaken aan de lamp of leiden tot lichamelijk letsel aan personen.

**FRANÇAIS****ATTENTION!**

Une mauvaise installation peut être source de blessures corporelles et endommager les lampes.

**SVENSKA****AKTA!**

Felaktig installation kan leda till skador pÙ personer och lampan.

**SUOMI****HUOMIO!**

Valaisimen huolimatton asennus voi johtaa henkilön loukkaantumiseen ja valaisimen vioittumiseen.

**РУССКИЙ****ОСТОРОЖНО!**

Неадекватный монтаж может привести к серьезным травмам и повреждению лампы.

**日本語****注意!**

不適切な取り付けは人の傷害、およびランプの損傷の原因となる場合があります。

**ITALIANO****ATTENZIONE!**

L'installazione non corretta puÙ causare lesioni alle persone e danni alla lampada.

## BEFORE YOU BEGIN

1. Please read this manual thoroughly before use, and retain it for future reference.
2. Due to our continuous program of product development, data is subject to change without notice.
3. Unauthorized product tampering invalidates warranty & is a safety risk.
4. All electrical work must be carried out by qualified persons.
5. Always follow appropriate electrical codes.
6. Disconnect mains power before product installation, connection, or disconnection.
7. Products are fixed luminaires for indoor use (i.e. Install out of reach / Only movable using tools).
8. LED-modules are non-replaceable light sources.
9. Do not use luminaires without LED Drivers (power units) connected (BX-, C-Series).
10. Connect LED drivers to electrical branch circuits (ensure suitable strain relief is fitted).
11. Products with an earth connection must be earthed for safety.
12. Installation of additional electrical circuit protection devices is strongly advised:
  - Type C MCB's (Miniature Circuit Breakers).
  - RCD (Residual Current Device).
  - ICL (Inrush Current Limiter).
  - SPD (Surge Protection Device).
13. Do not high voltage test.
14. Install LED drivers against a flat surface to ensure optimal heat dissipation and lifetime (BX-, C-Series).
15. Do not connect products installed on different mains phases to the same dimming device (dimnable products only).
16. Observe published product temperature specifications and limits.
17. Product surface temperature may become hot to the touch during use.
18. Do not stare directly at any bright light source.
19. As a precaution, use suitable eye protection if working for long periods under high intensity lighting.
20. Dispose of all waste in accordance with local regulations.
21. The external flexible cable of the luminaire is only replaceable by Valoya.
22. For luminaries supplied with open-end supply cables:
  - a. Cables should not be concealed or extended through parts of the building structure.
  - b. Cables should not be located above a suspended/dropped ceiling, or permanently fixed to the building structure.
  - c. Cables must be visible over their full length, not strained, and protected from physical damage.
  - d. Cables must be used within their electrical ratings at the maximum temperature of the installed environment.

### IMPORTANT

Installation must be carried out by qualified persons, and according to the electrical safety rules & regulations applicable in your country!



**RoHS**

**PATENTS APPLY**



**DELIVERY CHECK**

- Please inspect the goods upon receipt to ensure that your delivery is complete.
- If you detect any damage to the packaging, please notify the carrier immediately and ask them to note that “the delivery was not delivered in good condition”.
- If the packaging shows no damage but the goods inside are either missing, defective, or show other signs of damage, please contact us.
- In all cases please take pictures as evidence and contact us as soon as possible by phone or e-mail.

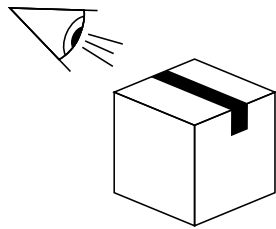

Check package

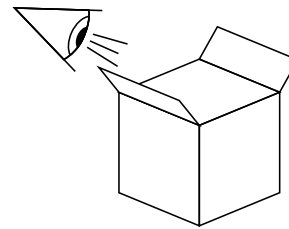

Check content

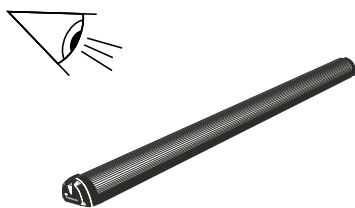

Check operation

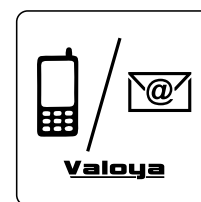

If problems, contact us

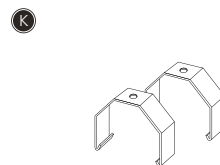
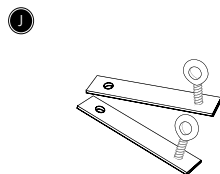
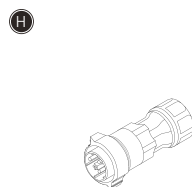
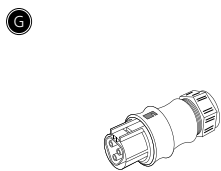
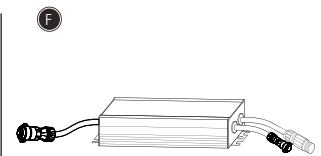
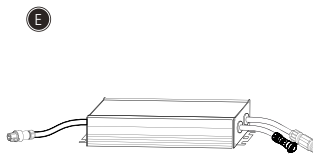
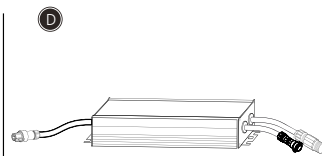
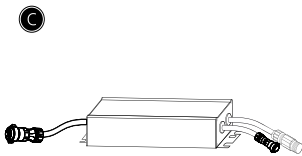
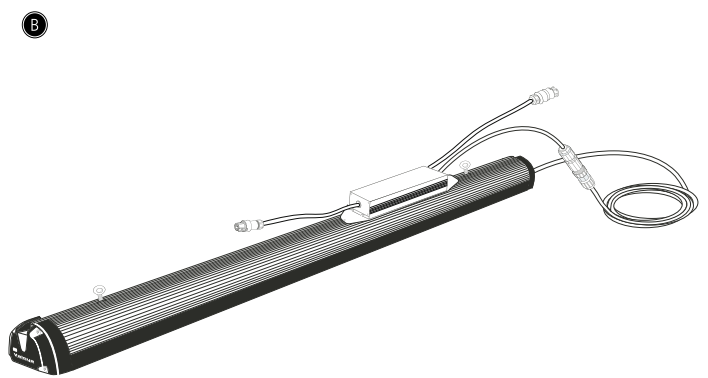

- Ⓐ Luminaire - option A
- Ⓑ Luminaire - option B
- Ⓒ ELG Driver, optional order for option A
- Ⓓ HVGC Driver, optional order for option A
- Ⓔ TLD Driver, optional order for option A
- Ⓕ BLD Driver, optional order for option A
- Ⓖ Mains input connector, field installable - For D, E drivers
- Ⓗ Mains input connector, field installable - For C, F drivers
- Ⓘ Dimmer connector with pigtail cable - For all drivers
- Ⓙ Standard hanger (included)
- Ⓚ Optional hanger for luminaire option A (order separately)



SPECIFICATIONS (TYPICAL)		BX120 Solray™			
Electrical & Physical Luminaire & LED Driver	Total Power (W)	135			
	Input voltage, nominal by driver	ELG	HVGC	TLD	BLD
		100, 200-305	180, 200-528	180-528	90-305
	Input current (A)	0.8 A @230 VAC			
	Frequency (Hz)	50 / 60			
	Power Factor	> 0.93			
	Dimmable (IEC 60929 Annex E)	Yes (0-10V / PWM): LED driver is a current source device			
	AC mains plug fitted	Yes			
	Luminaire Insulation class	Class I: For Fixed Installations (protective earth required)			
	16A Type-C MCB load (max @230 VAC.)	6			
	Luminaire weight (kg/lb)	2.6 / 5.7			
	LED Driver weight (kg/lb)	1.5 / 3.3			
	Minimum cable bending radius	5x cable diameter			
Optical	Efficiency, 380-820nm (PPF)	Up to 2.4 $\mu\text{mol/W}$ (Spectrum dependent)			
	Light output ( $\mu\text{mol/s}$ ), Spectrum dependent	320			
	Light intensity decay, Q90 / L90 (hours)	36000			
	Typical use life, Q90 / L70 (hours)	50000			
Environmental Luminaire only	Operational ambient temperature range ( $^{\circ}\text{C}/^{\circ}\text{F}$ )	0...+40 / +32...+104			
	Max. allowed luminaire housing (tc) temperature ( $^{\circ}\text{C}/^{\circ}\text{F}$ )	75 / 167			
	Maximum Relative Humidity (%)	90 (non-condensing)			
	Storage temperature ( $^{\circ}\text{C}/^{\circ}\text{F}$ )	-20...+40 / -4...+104			
	Ingress Protection (IP) rating	IP 67			
	Cooling method	Passive cooled			
Regulations & Approvals	CE marked	X			
	RoHS compliant	X			
	EMC directive compliant	X			
	Low Voltage Directive compliant	X			
	Eco-design (EuP) directive compliant	X			
	Certified to UL & CSA standards	X			
Packaging	Pieces per box (luminaire / PSU)	2 / 2			
	Box length (mm/in)	1450 / 57			
	Box width (mm/in)	260 / 10.2			
	Box height (mm/in)	75 / 3			
	Box weight (kg/lb)	10.3 / 22.7			

### Notes:

- Electrical values are typical nominal figures (variations may occur due to spectrum, component & production tolerances).
- Due to our continuous program of product development, specifications are subject to change without notice in order to improve spectra, function, performance & reliability.
- Due to manufacturing tolerances, slight variations are possible in cable lengths, weights & package dimensions.





## PRODUCT DIMENSIONS

		LUMINAIRE DIMENSION	
		OPTION A	OPTION B
A	Length (mm/in)	1176 mm / 46.3 in	
B	Height (mm/in)	58 mm / 2.3 in	93 mm / 3.7"
C	Width (mm/in)	73.5 mm / 2.9 in	

**OPTION A**

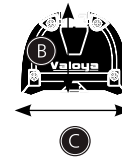

**OPTION B**

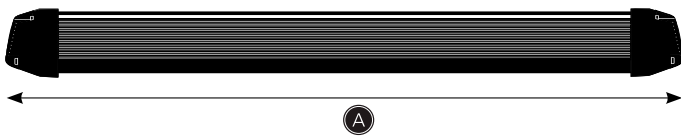
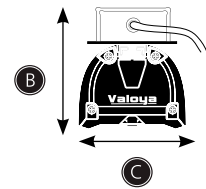

	LED DRIVER (POWER UNIT)				
	ELG	HVGC	TLD	BLD	
A	Length (mm/in)	219 mm / 8.6 in	245 mm / 9.6 in	251 mm / 9.8 in	188 mm / 7.4 in
B	Width (mm/in)	63 mm / 2.5 in	68 mm / 2.7 in	68 mm / 2.7 in	68 mm / 2.7 in
C	Height (mm/in)	35 mm / 1.4 in	38.8 mm / 1.5 in	38.5 mm / 1.5 in	33.5 mm / 1.3 in
D	Screw holes distance (mm/in)	208 mm / 8.2 in	225.8 mm / 8.9 in	225.8 mm / 8.9 in	176 mm / 6.9 in
E	Screw holes distance (mm/in)	45.8 mm / 1.8 in	34.2 mm / 1.3 in	34.2 mm / 1.3 in	34.2 mm / 1.3 in
F	Screw hole (mm/in) (x4)	Ž4.5 mm / 0.2 in	Ž4.2 mm / 0.2 in	Ž4.2 mm / 0.2 in	Ž4.2 mm / 0.2 in

**ELG DRIVERS**

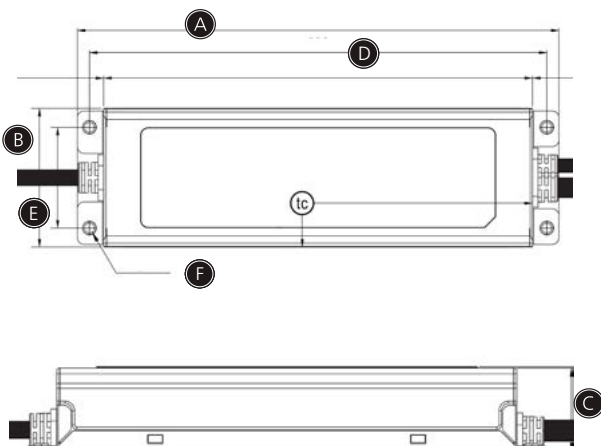

**HVGC, TLD, BLD DRIVERS**

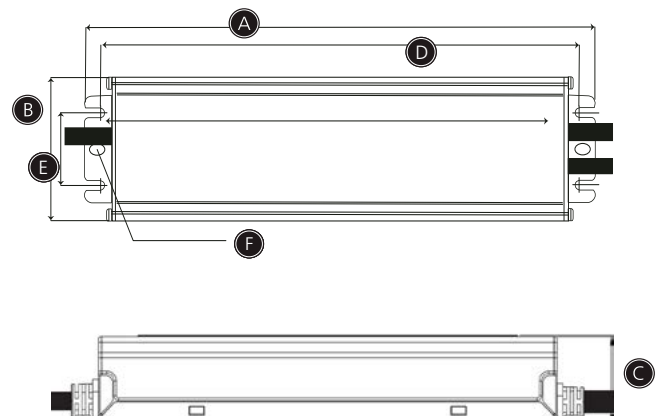



## PRODUCT DIMENSIONS

STANDARD HANGER (2X)		
A	Length (mm/in)	70 mm / 2.8 in
B	Width (mm/in)	14 mm / 0.6 in
C	Height (mm/in)	3 mm / 0.1 in
D	Screw hole	M5 thread
E	Hanger height (mm/in)	35 mm / 1.4 in

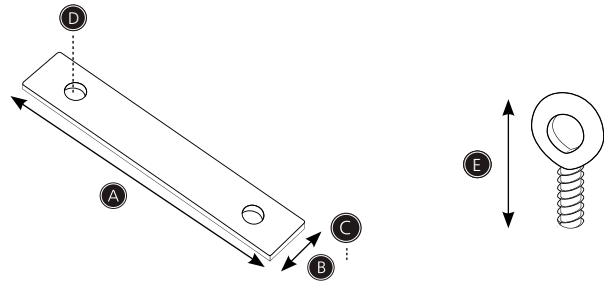

OPTIONAL HANGER (2X)		
A	Length (mm/in)	76 mm / 3 in
B	Width (mm/in)	20 mm / 0.8 in
C	Height (mm/in)	70 mm / 2.8 in
D	Hole diameter (mm/in)	5 mm / 0.2 in

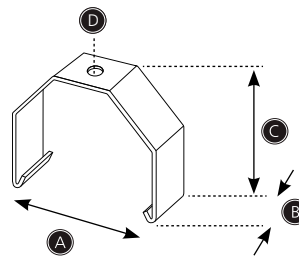

### Notes:

- Optional hangers are not suitable for luminaire option B where the driver is placed on top of the luminaire!

CABLES			
		OPTION A	OPTION B
A	Mains cable (mm/in)	300 mm / 11.8 in	300 mm / 11.8 in
B	DC cable LED Driver (mm/in)	300 mm / 11.8 in	300 mm / 11.8 in
C	Dimming cable (mm/in)	300 mm / 11.8 in	300 mm / 11.8 in
D	DC cable luminaire (mm/in)	1000 mm / 40 in	1000 mm / 40 in
E	Dimming cable (mm/in)	1800 mm / 72 in	1800 mm / 72 in

### OPTION A

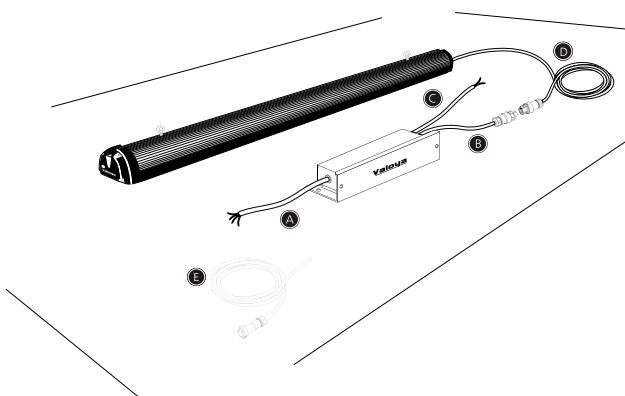

### OPTION B

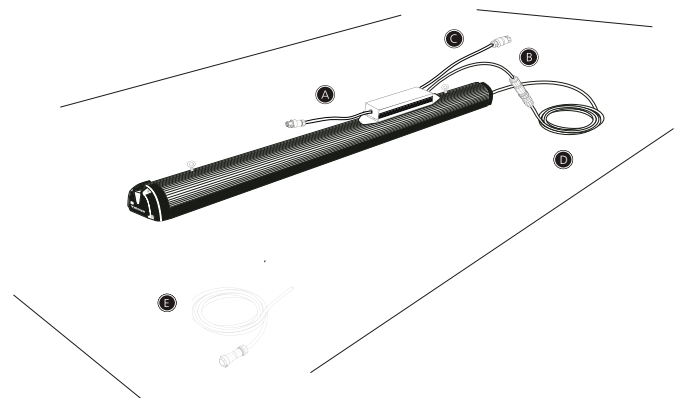





**LUMINAIRE INSTALLATION - OPTION A**

**METHOD A (STANDARD HANGER)**

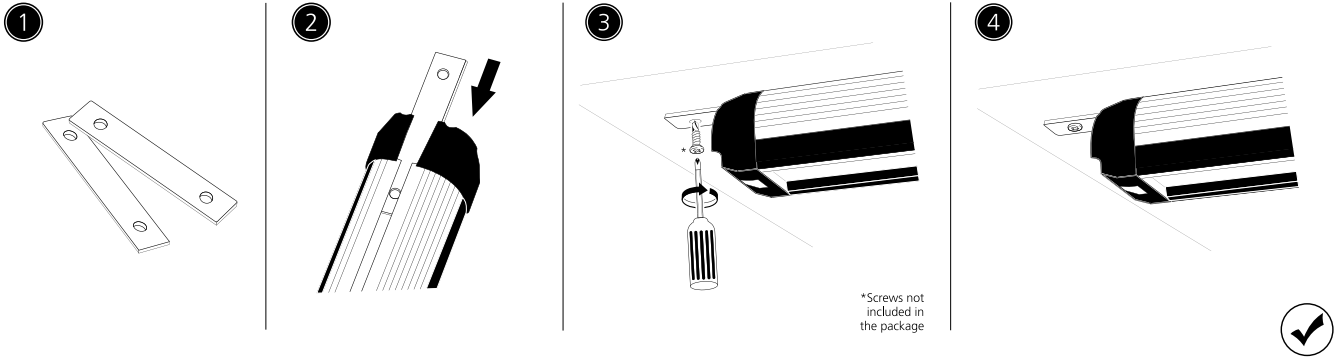

**METHOD B (STANDARD HANGER)**

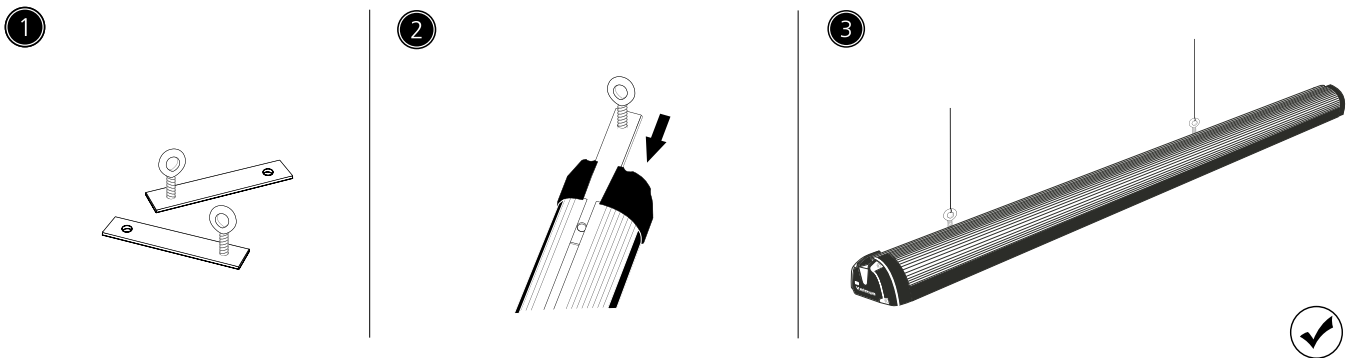

**METHOD C (OPTIONAL HANGER)**

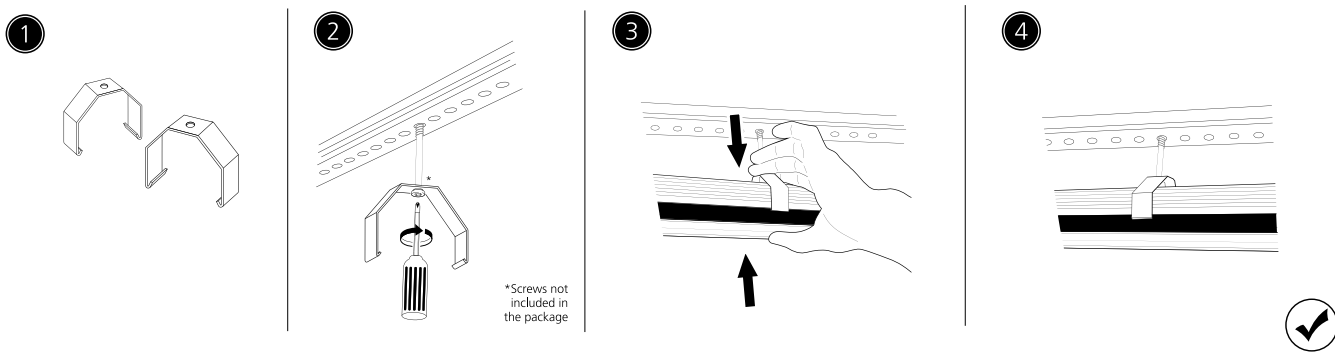



## LUMINAIRE INSTALLATION - OPTION B

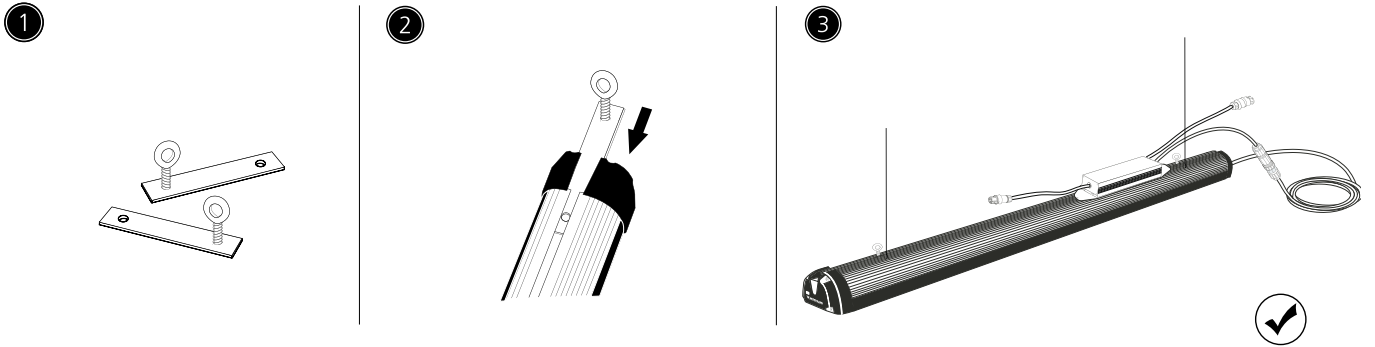

## LUMINAIRE ORIENTATION

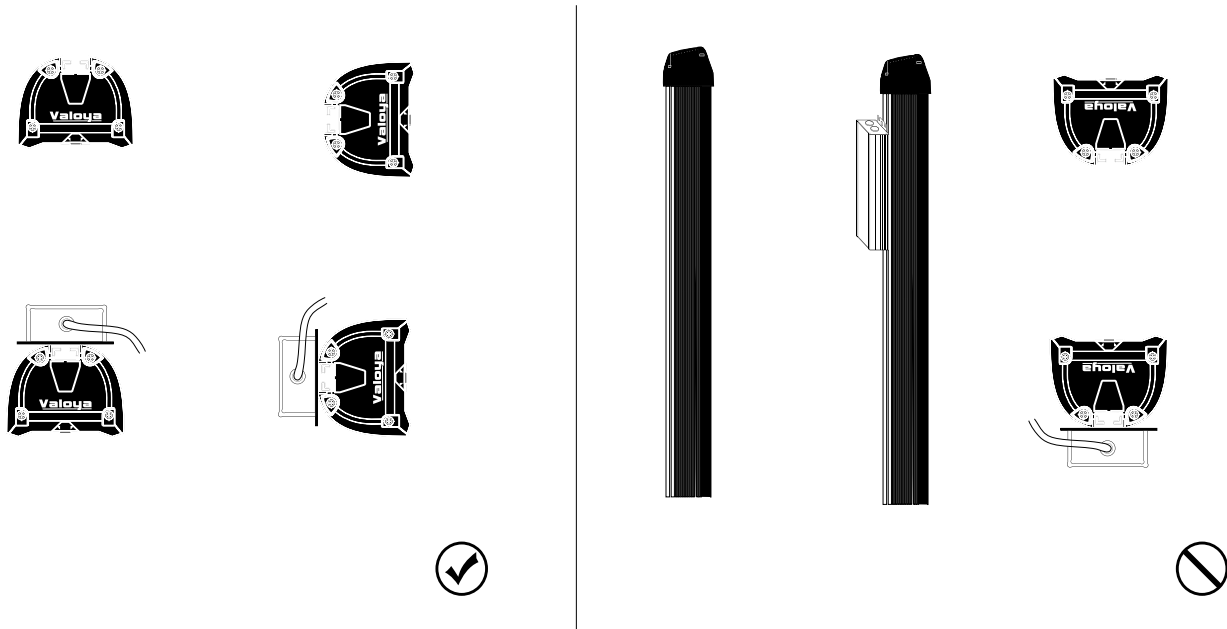

## LED DRIVER INSTALLATION

1



Installation above a surface

2

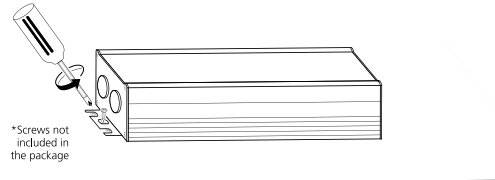

Installation below a surface

3

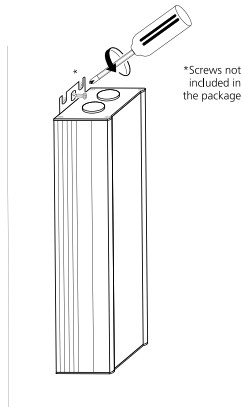

Vertical installation

4

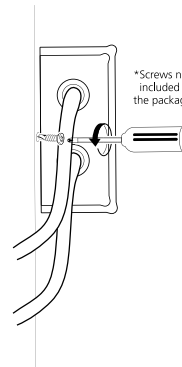

Horizontal installation

### NOTES

- Install LED drivers against a flat surface to ensure optimal heat dissipation and operational lifetime.
- The mounting surface must be made of non-combustible / non-flammable material

## LED DRIVER PLACEMENT EXAMPLES

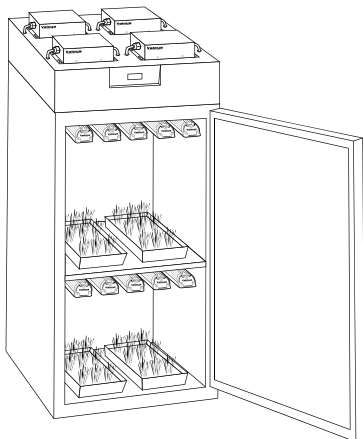

LED drivers installed outside a growth chamber

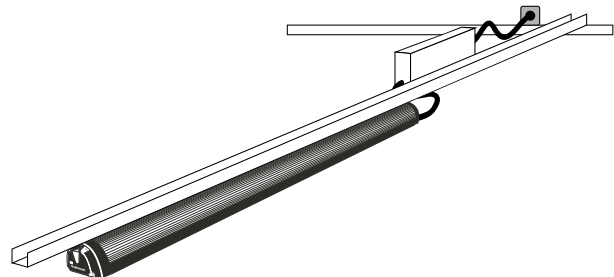

LED driver installed next to the luminaire



## ELECTRICAL CONNECTION PROCEDURE

### Luminaire connection - Option A

- 1) Connect luminaire to LED driver
- 2) Connect a compatible dimming controller (if used) to the LED Driver's "DIM+" and "DIM-" connection. Electrically isolate wires if no controller is connected.
- 3) Connect LED Driver to mains supply (Live, Neutral, Earth).

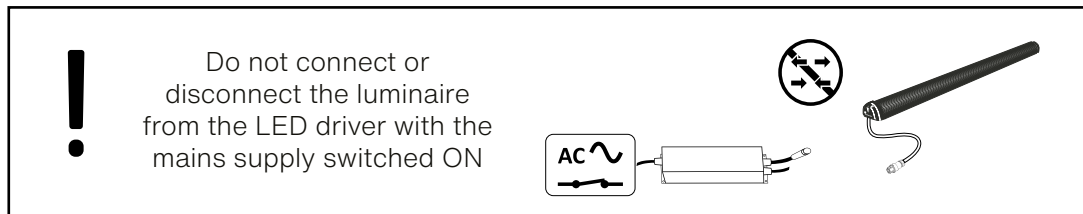
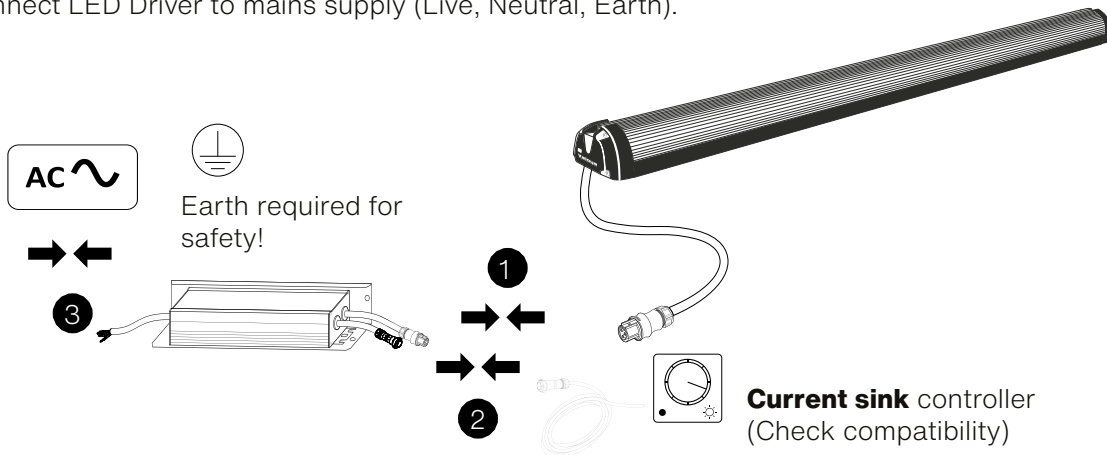

### Luminaire connection - Option B

- 1) Connect a compatible dimming controller (if used) to the LED Driver's "DIM+" and "DIM-" connection. Electrically isolate wires if no controller is connected.
- 2) Connect LED Driver to mains supply (Live, Neutral, Earth).

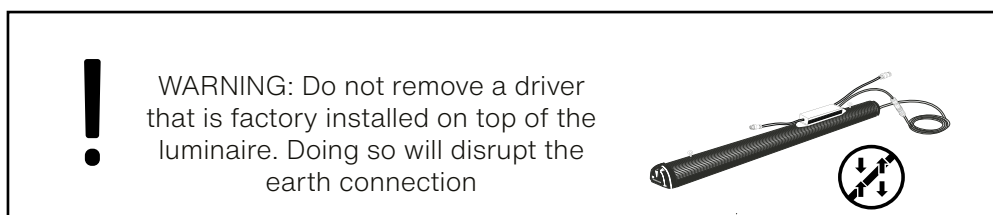
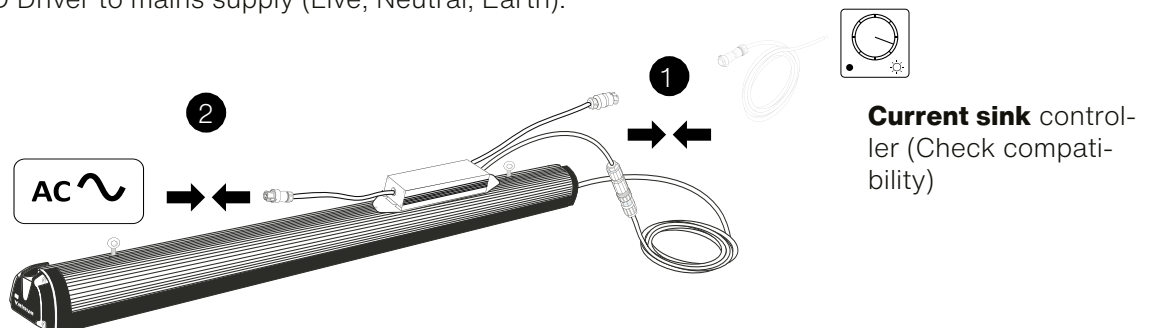

## ELECTRICAL CONNECTION PROCEDURE

### Wieland mains input connector connection (with drivers HVGC and TLD)

Connect your incoming mains cable to the Wieland RST female connector (ZHPF8144) as shown below.

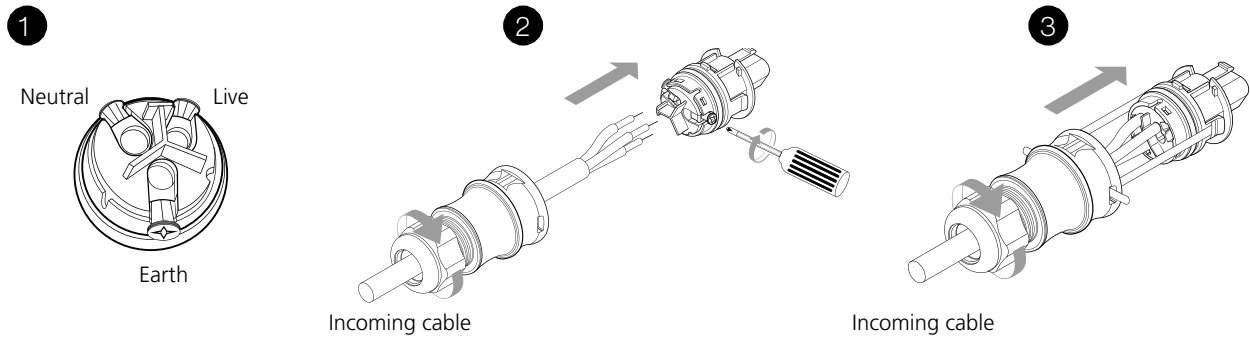

### Amphenol DC mains input connector connection (with drivers ELG and BLD)

Connect your incoming mains cable to the Wieland RST female connector (ZHPF8144) as shown below.

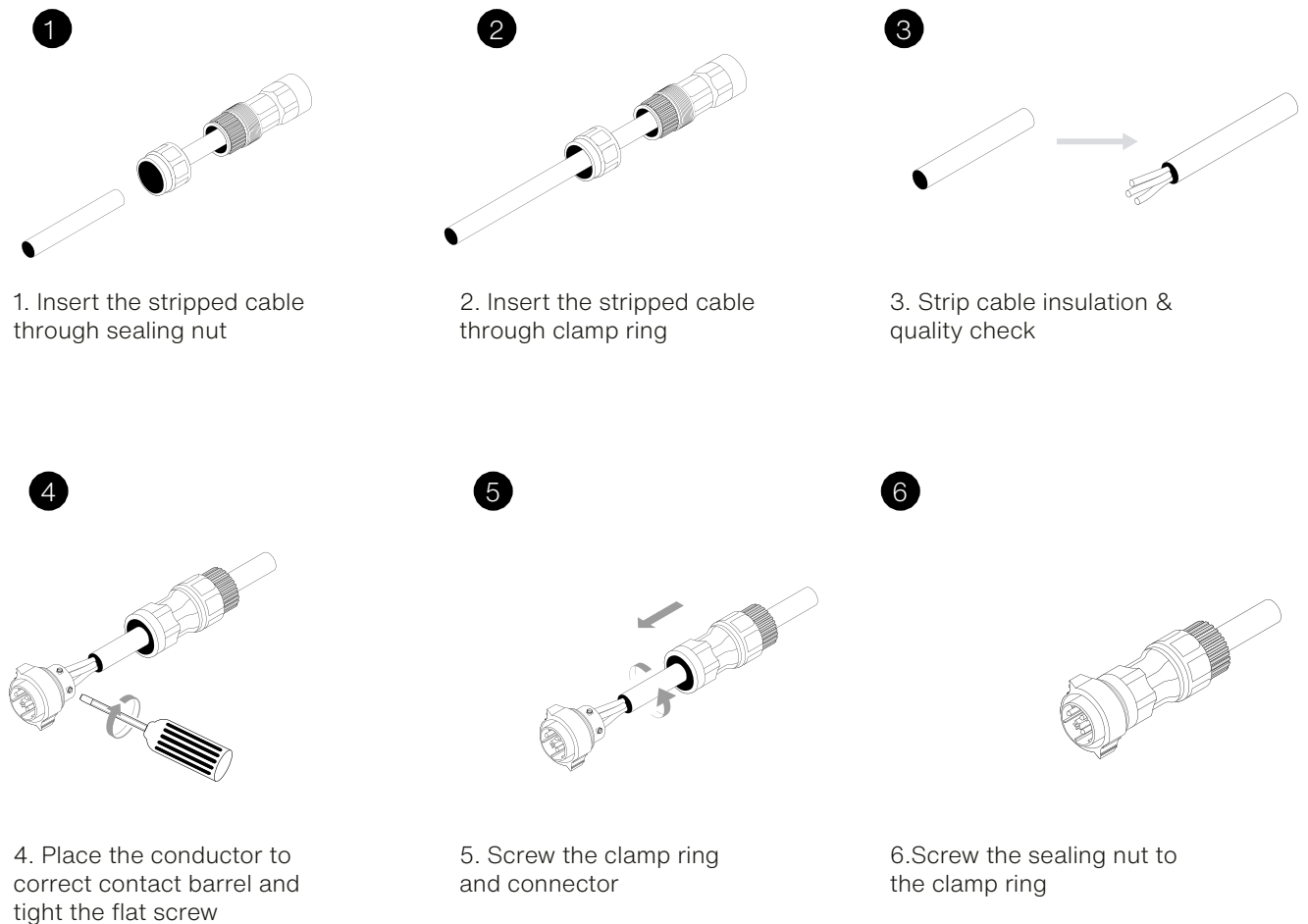



### INRUSH CURRENT

This is the initial current surge drawn during product start-up. Total inrush current rises as the circuit load increases and is one factor that can contribute to nuisance tripping of circuit breakers (MCB's). Practical performance will be affected by the MCB load, MCB tripping characteristics, site wiring impedance, and the angle of the AC mains cycle at the specific moment power is applied.

Nuisance tripping issues may be improved by:

- Reducing the quantity of LED drivers connected to a single MCB.
- Re-distributing the load over multiple mains phases.
- Using an MCB with Type C (EN 60898) tripping characteristics.
- Installing additional inrush current limiting devices.
- Installing a zero crossing relay for powering up the LED drivers.

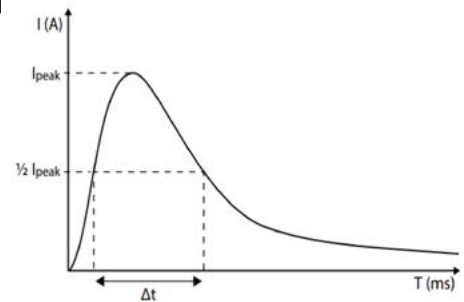

Example of a typical inrush current graph

### MCBS (MINIATURE CIRCUIT BREAKERS)

Valoya only recommend using MCB's with "Type C" trip characteristics according to EN 60898.

The maximum quantity of Valoya products recommended for a 16A Type C MCB is stated on the product's technical specifications datasheet (e.g installation guide). This quantity is used as the 100% reference in the table below. The table is provided as a tool to enable calculation of the approximate maximum load for different MCB types and ratings. Installation wiring rating, impedances and mains switch-on angle variations may also influence the actual practical limit.

**20A branch circuit is the maximum allowed per UL certification according to LED Drivers UL Conditions of Acceptability.**

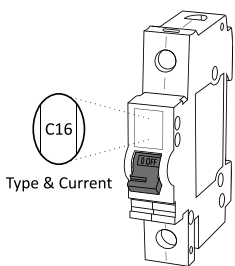

MCB example

MCB TYPE	Rating (A)	Relative quantity (%)
<b>B</b>	10	37
	16	60
	20	75

MCB TYPE	Rating (A)	Relative quantity (%)
<b>C</b>	10	62
	16	<b>100 (Ref.)</b>
	20	125

### ICL (INRUSH CURRENT LIMITER)

An ICL can help avoid nuisance MCB tripping and can be installed between the MCB and the load. It also enables an increase the luminaire quantity up to the maximum RMS current limit of the Inrush Current Limiter.

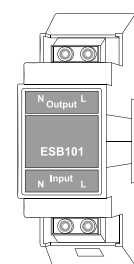

ICL example





## RCDS (RESIDUAL CURRENT DEVICES)

An RCD is a protective safety device used to automatically disconnect the electrical supply when an imbalance is detected between live conductors. Requirements for use, and the needed RCD rating, will vary depending on the type of installation. Valoya luminaires are designed to be installed in fixed electrical installations where no plug is permitted for connecting the luminaire to the mains supply.

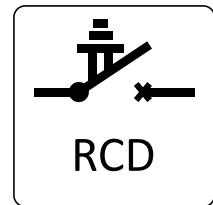

## SURGE PROTECTORS

Valoya LED drivers have built-in surge protection. However, to protect against surge peaks above 4KV (e. g. Due to a lightning strike) we recommend the installation of transient voltage surge suppression.

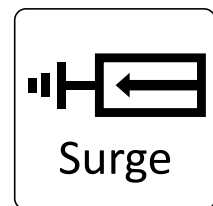

## 3-PHASE SUPPLIES

- Do not apply power without the Neutral connected.
- Ensure the supply is off before disconnecting the Neutral.
- To avoid erratic dimming or possible product damage, do not connect the same dimmer or controller to luminaires supplied by different mains phases.

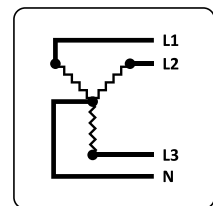

## INSULATION RESISTANCE/ ELECTRIC STRENGTH TESTING

- Valoya products have been fully tested during manufacture. There is no need to test again.
- If the electrical site wiring must be tested, test with the luminaires and LED drivers disconnected from the mains supply.
- If luminaires and LED drivers are connected to the mains supply during the test, all Live phases and Neutral must be connected together before the test is carried out (Remember to check correct reconnection before reapplying the mains supply).

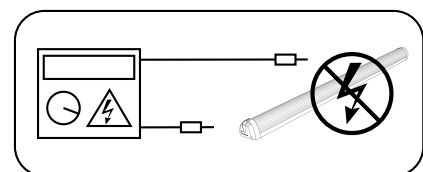



## DIMMING METHODS

Differences in dimming methods exist depending on the LED driver (power unit) used by the Valoya luminaire.

- 1-10V: Minimum dimmed light output is approximately 10% (Spectra dependent). The mains supply to the driver must be switched in order to turn the light on & off.
- 0-10V: Minimum dimmed light output is approximately 6% (Spectra dependent). Below this the light output is off without the need for mains switching.

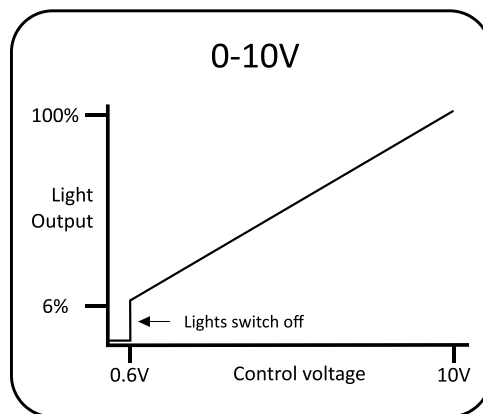
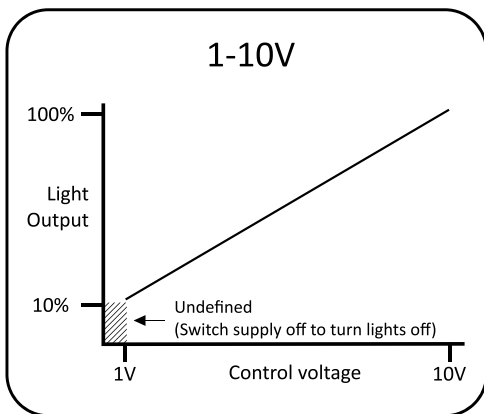

## DIMMING CONTROL COMPATIBILITY

LED drivers used by Valoya comply with International standard for current sink controls; IEC 60929 Annex E. This specifies that the LED driver is a current source device. Compatible controls MUST be capable of sinking the current provided by the LED driver. Controls supplying a 10V signal ARE NOT compatible.

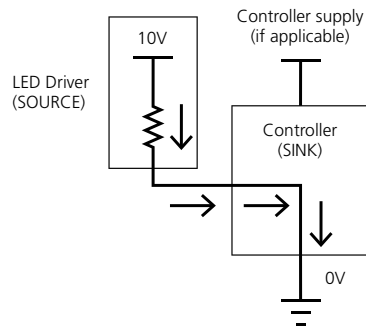

DIMMING POSSIBILITIES BY PRODUCT RANGE				
BX-Series	BL-Series	L-Series	C-Series	RX-Series
1-10V	-	-	0-10V	0-10V





## DIMMING CONTROL COMPATIBILITY

### Important considerations when choosing a controller

- Please check with you controller provider regarding the specification of the device.
- The number of luminaires possible to connect to a single control device will depend its specification, specifically:
  - The dimming method (1-10V or 0-10V).
  - The control circuit current sink capability.
  - Mains switch inrush current capacity.
- Dimming controls should only be connected to LED drivers on the same mains phase. Cross phase connection may lead to differing control circuitry electrical potentials, reduced dimming performance, or permanent damage to LED drivers

Due to variations in specifications, terminology and connections between different control device manufacturers, it is impossible to list all possible alternatives. The controller manufacturer will be able to verify that their product is a current sink device compatible with LED drivers designed according to IEC60929 Annex E.

### Examples of manufacturers of compatible control products/systems (some example products indicated).

MANUFACTURERS	WEBSITE	EXAMPLE PRODUCT
ABB	<a href="http://www.abb.com">www.abb.com</a>	1-10 V 2112UJ-214-510
Argus	<a href="http://www.arguscontrols.com">www.arguscontrols.com</a>	P1A
Dinuy	<a href="http://www.dinuy.com">www.dinuy.com</a>	RE EL5 002
Ever Shining Optotech Co., Ltd	<a href="http://www.esop-power.com">www.esop-power.com</a>	EC011
Helvar	<a href="http://www.helvar.com">www.helvar.com</a>	140 (TK4)
Honeywell Peha	<a href="http://www.peha.de">www.peha.de</a>	D 430
Jung	<a href="http://www.lutron.com">www.lutron.com</a>	Electronic potentiometer, 1-10 V
Lutron	<a href="http://www.jung.de">www.jung.de</a>	
Osram	<a href="http://www.osram.com">www.osram.com</a>	Dim MCU 1-10V
Philips	<a href="http://www.lighting.philips.com">www.lighting.philips.com</a>	UID8600/00 1-10V Dimmer
Priva	<a href="http://www.priva.com">www.priva.com</a>	
RAM	<a href="http://www.ram-group.com">www.ram-group.com</a>	
Siemens	<a href="http://www.siemens.com">www.siemens.com</a>	5TC8424



## DIMMING CONNECTION EXAMPLES

### Using a simple potentiometer (1-10V / 0-10V)

One LED driver can be connected to a standard 100KOhm potentiometer. Note that connection of multiple LED drivers to one 100KOhm potentiometer is not recommended due to possibilities for erratic dimming performance

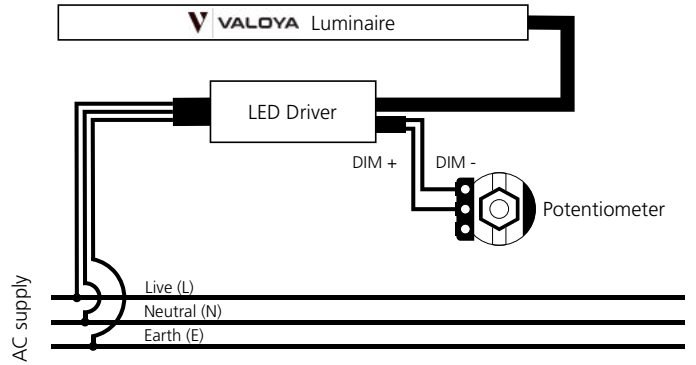

### Using a compatible current sink 1-10V dimmer

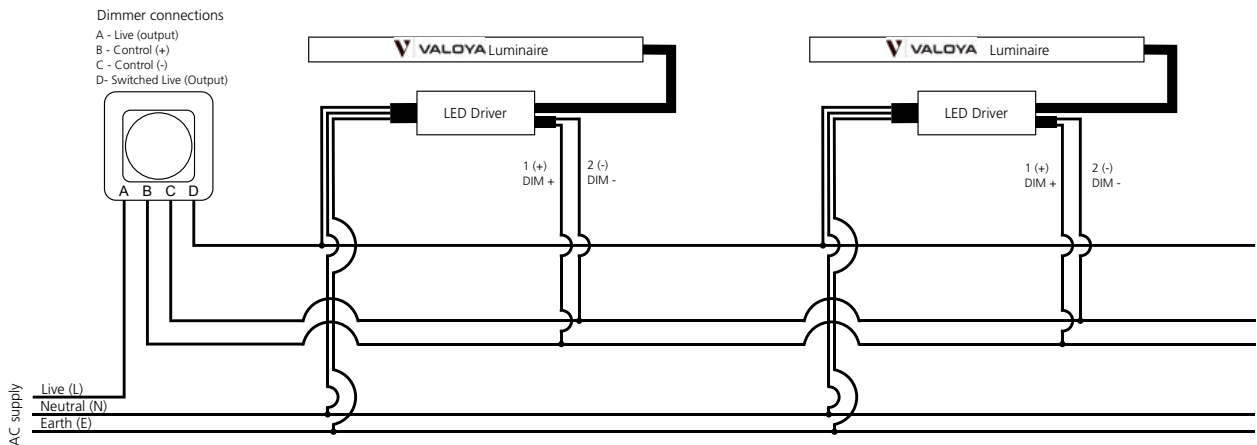

### Using a compatible current sink 0-10V dimmer

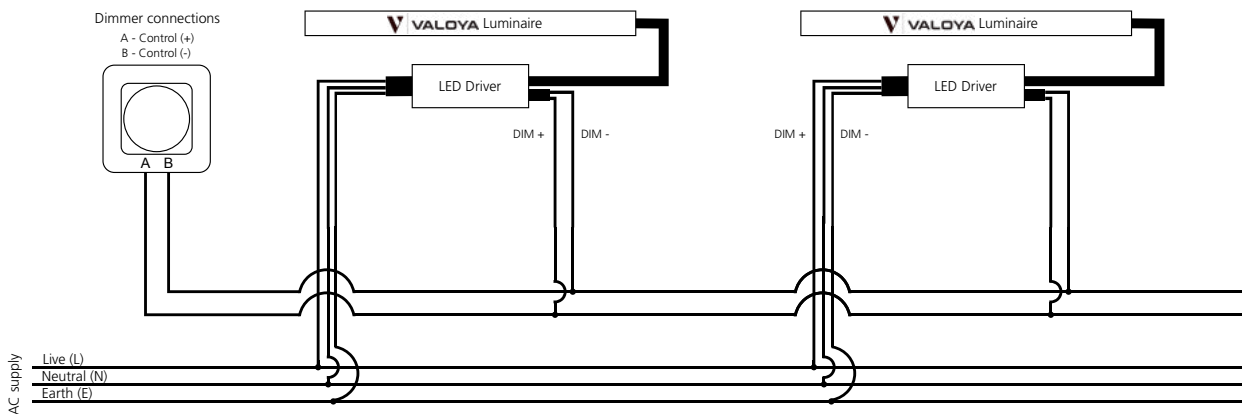



## CLEANING

Switch the supply OFF

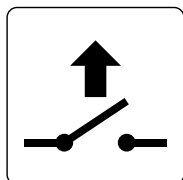

Allow to cool

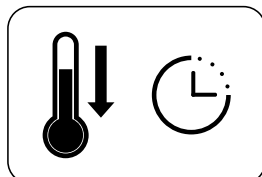

Do not use detergent



Clean with a soft brush



Wipe with soft clothes



Suitable for spray cleaning with water

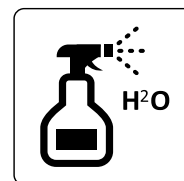

## BASIC FAULT FINDING

Lighting faults can be due to a rare product defect, connection error, or other external issue. Faults are unlikely to affect both luminaire and the LED driver (power unit) together. If possible, please check if the issue is luminaire or LED driver related. This will speed problem resolution and minimize unnecessary shipping costs.

- Switch off the mains supply.
- Disconnect the luminaire from its LED driver.
- Connect the luminaire to an unpowered, working LED driver (if available).
- Connect the mains supply to the working LED driver.
- If the problem remains, then the luminaire may be damaged.
- If the luminaire now works, then the original LED driver, or mains supply to it may be at fault.
- Note details of the problem (product type, quantity, problem description...) and contact Valoya for further assistance.

If a problem reoccurs or affects many products at the same time, please contact Valoya ([www.valoya.com/support](http://www.valoya.com/support)) for further advice and assistance.





## WARRANTY

Products are covered by a limited warranty. Warranty starts from date of installation, but latest 3 months from the delivery date.

The warranty offered is “Return-to-Base”, meaning suspected faulty items shall be returned to Valoya for fault and warranty validation before any repair or replacement can be agreed.

Valoya warrants that each Product will be free from defects in material and workmanship for the duration of the warranty period as long as the products are installed and used in accordance with our published specifications and recommendations.

Warranty shall be void in the event any repairs or alterations not duly authorized by Valoya in writing are made to the Product by any person.

## CLAIMS

Before returning a suspected faulty item, please contact Valoya (**[www.valoya.com/support](http://www.valoya.com/support)**) to give details of the issue and obtain a Return Material Authorization (RMA) reference number. Please be prepared to provide the following information about the issue:

- Product model information (e.g. B200 NS1).
- Product serial number plus YF or XF code.
- Quantity showing problems.
- Detailed problem description.
- Photograph or video showing the issue (if possible).
- Installation / invoice date (if known).

After receiving an RMA number, Products should be suitably packed and the package or shipping paperwork clearly marked with the RMA number. Returns received without an RMA reference number may be rejected.

Valoya will inspect the returned items to validate fault and warranty validity. If Valoya determines to its satisfaction that warranty is valid, Valoya will repair or replace the Product with one of similar age. Where a warranty claim is justified, Valoya will pay for the return freight expenses for repaired or replaced items. Valoya reserve the right to invoice for returning Products that are not found to be defective, or do not comply with the terms of this warranty, together with associated freight, testing and handling costs.

**\* Above is a summary of our warranty and claim policy. For full details please see: [www.valoya.com/warranty](http://www.valoya.com/warranty).**

## Standards applied (where applicable):

### EUROPE

**EN60598-1:** Luminaires. General requirements and tests.

**EN60598-2-1:** Luminaires. Part 2: Particular requirements. Section one – Fixed general purpose luminaires.

**EN62031:** LED modules for general lighting. Safety specifications.

**EN 62493:** Assessment of lighting equipment related to human exposure to electromagnetic fields.

**EN55015:** Limits and methods of measurement of radio disturbance characteristics of electrical lighting and similar equipment.

**EN61547:** Equipment for general lighting purposes. EMC immunity requirements.

**EN61000-3-2:** Electromagnetic compatibility - Limits - Limits for harmonic current emissions.

**EN61000-3-3:** Electromagnetic compatibility – Limits - Limits for Voltage Fluctuations and Flicker.

**IEC EN 61000-4-2:** Electromagnetic compatibility (EMC)- Part 4-2: Testing and measurement techniques - electrostatic discharge immunity test.

**IEC EN 61000-4-3:** Electromagnetic compatibility (EMC)- Part 4-3: Testing and measurement techniques - radiated, radio-frequency, electromagnetic field immunity test.

**IEC EN 61000-4-4:** Electromagnetic compatibility (EMC) - Part 4-4: Testing and measurement techniques - Electrical fast transient/burst immunity test.

**IEC EN 61000-4-5:** Electromagnetic compatibility (EMC) - Part 4-5: Testing and measurement techniques - Surge immunity test.

**IEC EN 61000-4-6:** Electromagnetic compatibility (EMC) - Part 4-6: Testing and measurement techniques - Immunity to conducted disturbances, induced by radio-frequency fields.

**IEC EN 61000-4-8:** Electromagnetic compatibility (EMC) - Part 4-8: Testing and measurement techniques - Power frequency magnetic field immunity test.

**IEC EN 61000-4-11:** Electromagnetic compatibility (EMC) - Part 4-11: Testing and measurement techniques - Voltage dips, short interruptions and voltage variations immunity tests.

**IEC 61347-2-13:** Lamp controlgear. Particular requirements for d.c. or a.c. supplied electronic controlgear for LED modules.

**IEC 61347-1:** Lamp controlgear - Part 1: General and safety requirements.

**IEC 62384:** DC or AC supplied electronic control gear for LED modules. Performance requirements.

**EN62471:** Photobiological safety of lamps and lamp systems.

**EN62560:** Self-ballasted LED-lamps for general lighting services by voltage >50V - Safety specifications.

**EN62776:** Double-capped LED lamps designed to retrofit linear fluorescent lamps - Safety specifications.

### NORTH AMERICA

**UL1598:** Luminare safety.

**UL8750:** Light Emitting Diode (LED) equipment for use in lighting products.

**UL2108:** Standard for Low Voltage Lighting Systems.

**UL 8800:** Outline of Investigation for Horticultural Lighting Equipment

**CSA C22.2: #9.0:** General Requirements for Luminaires.

**CSA C22.2: #250.0.8:** Safety for Light emitting diode (LED) equipment for lighting applications.

**CSA C22.2 No. 250.13-14:** Light Emitting Diode (LED) equipment for use in lighting products.

---

#### Contact:

Melkonkatu 26,  
00210 Helsinki,  
Finland

**T** +358 10 2350 300

**E** sales@valoya.com

**W** www.valoya.com

#### Distributor list can be found at:

[www.valoya.com/contact](http://www.valoya.com/contact)

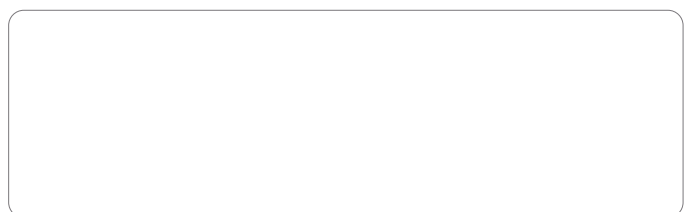

---

Valoya® is a registered trademark of Valoya Oy in the European Community, the USA and certain other countries.

Due to our continuous program of product development, data is subject to change without notice.