

3-Axis Laser Marking & Engraving

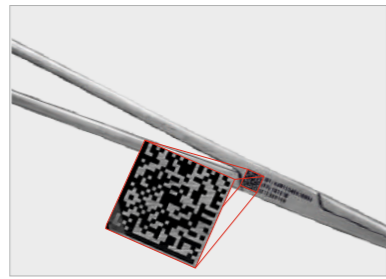

Annealing / Colored Marking on 3D Surface



Medical Part UDI marking, Corrosion & Passivation Resistant High Contrast black Annealing



2D DPM Marking on Electrical Parts



Cutting & Marking on Special Adhesive TESA & 3M Tapes

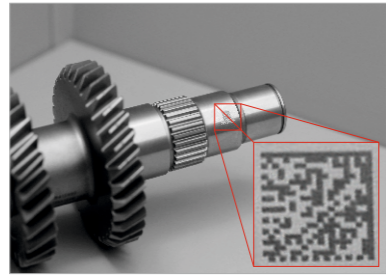

DPM Of Data Matrix Code On Automotive Gear Assembly Part



UDI On Glass Ampules

**Please read our warranty terms and conditions

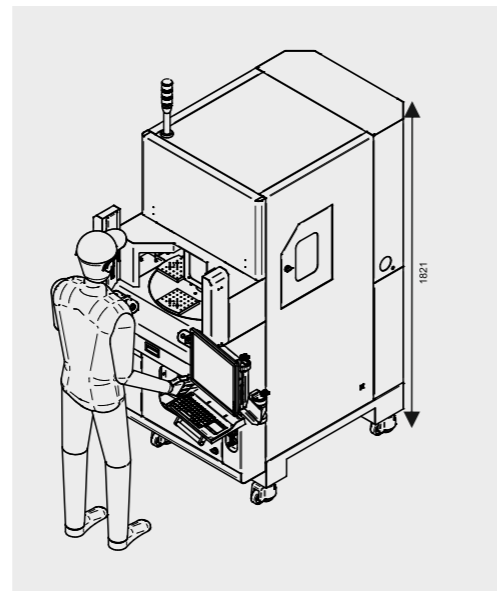
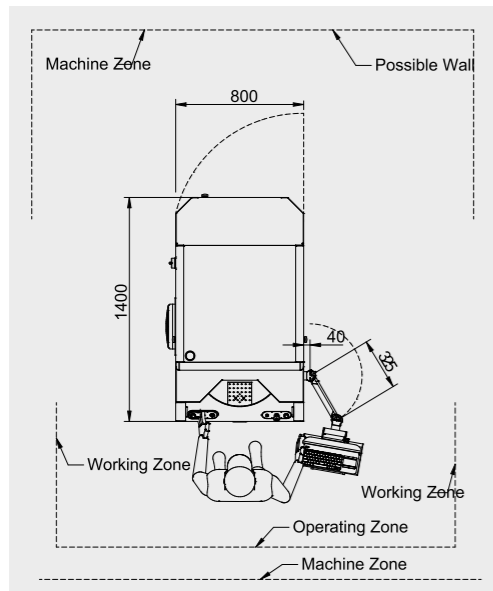

Subject to technical alterations. Dimensions without obligation 06/19/SEE

Spinks Impex : Plot no.81, Pace City-1,
Sec 37 Gurugram 122001, Haryana. India.
+91 9999902126, +91 9210626626

Email : info@markolaser.com
3d@markolaser.com

www.markolaser.com
www.jewelaser.com

service@markolaser.com



MARKOLASER
Solutions



ROTO

Productive And Versatile 3-Axis Laser Machine

Benefits at a Glance

3-Axis marking, engraving laser system.

Track and trace ready.

Integrated optical inspection system.

Semi-automatic with high productivity.

High precision & selectable multistation functionality.



Track & Trace Ready*

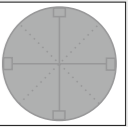

Indexer

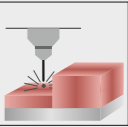

3-Axis Step Marking/Engraving

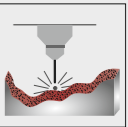

3-Axis Marking/Engraving



3-Axis Annealing



Vision Inspection System*

Disclaimer: These images are for illustration purpose only, the machine look may vary in real time

European components selected carefully

N.B. Markolaser reserves the right to change the design to upgrade the technology from time to time.
* Optional Items: Custom Made

Logos & Artworks Shown are Property of Respective Companies

Rotary Indexer

Programmable, multi-indexing options, semi-automatic.

3-Axis Laser System

3-Axis Laser marking/engraving system guided by SCANLAB GmbH.
Highest Quality DPM of Barcodes
(ISO/IEC 16022, ISO/IEC 16022, SEMI, SPEC 2000, FDA UDI)

Vision for post-inspection

Marking/engraving quality verification, OCV, Code quality verification (AIM-DPM or ISO/IEC TR 29158) positioning information, measurements etc.

High Precise Auto z-axis

High precision servo controlled auto z-axis for laser focussing.

Process view camera

Live view of the laser process.

Vision for pre-inspection

Part orientation, part segregation, part presence or absence and other pre-inspection options.

Safety curtains

Class 1 safe workstation with CE Compliance

Cooling system

Machine air conditioning system.

User Control Interface & iTracy™

Custom made UI with Single Process Control Interface. Real time events, alarms, health info, Production reports, live view & Authentication levels etc.

