

Internal Oil Boilers

from Flexiheat UK



FLEXIHEAT UK LTD
www.flexiheatuk.com
01202 822221

FHWS COMBI

The FHWS Combi is the only through the wall oil-fired Combi on the market. The Combi shares the benefits of the conventional FHWS and provides a complete central heating and hot water system mounted on the wall. The FHWS Combi is suitable for the smaller property with a heating requirement of up to 18kW. Output for domestic hot water (DHW) is 24kW. A flow regulator of 10.5 litres per minute ensures at least 35°C degree rise above mains water temperature.

Inside Casing

H 900mm W 475mm D 400mm

Outside Casing

H 580mm W 390mm D Telescopic

Key Benefits

- ✓ Space Saving
- ✓ Eliminates Odours
- ✓ Quieter
- ✓ Integral Balanced Flue
- ✓ Single Pipe Oil Supply
- ✓ 2 Year Parts & Labour Warranty
- ✓ 5 Years On The H/EX

Pipework Data

- ✓ Heating Flow & Return : 22mm End Feed
- ✓ Cold Feed Connection : 15mm Compression
- ✓ Drain Socket : 0.5" BSP
- ✓ Fuel : Class C2 (28 Sec Kerosene)
- ✓ Fuel Connection : 10mm
- ✓ Condensate Drain : 20mm

General Data

- ✓ Manual Reset High Limited Thermostat Is Fitted As Standard.
- ✓ 35C Rise At 10.5ltr / Min Flow Rate.
- ✓ Max Installation Height : 2.5m From Tank Outlet To Bottom Of Casing.
- ✓ Oil Filter, Non-Return Valve, Condensate Trap Included.
- ✓ Telescopic Flue & Wall Duct Range : 210-340mm
- ✓ Filling Loop.
- ✓ 10 Litre Expansion Vessel.





FHWS COMBI

Technical Information

Nozzle	0.75 80° EH
Oil Pressure	120 PSI
CO ²	12.5% + / -0.5%
Inner Adjustment Assembly	No. 20

Specifications

Product Code	FHWS COMBI
Number of Bedrooms	1, 2, 3
Number of Bathrooms	1, 2
Heating System	Combination
Circulating Pump	Grundfos UMP3
Condensate Drain	20mm
Condensate Trap	Included
Drain Socket	0.5" BSP
Expansion Vessel	10 Litres
Flow and Return	20mm
Frost Thermostat	Not Required

Fuel	Class C2 (28 Second Kerosene)
Fuel Connection	10mm
Integrated Balanced Flue	Included
Manual Reset High Limit Thermostat	Included
Max installation height	2.5 meters from Tank Outlet
Non-return Valve	Included
Oil Filter	Included
Output	24kW
Telescopic Flue & Wall Duct Range	210-340mm (W3CX100 +100mm Extension Kit available)
Tigerloop / Deareator	Not required
Warranty	2 years parts and labour 3 additional years on Water Jacket

Internal View

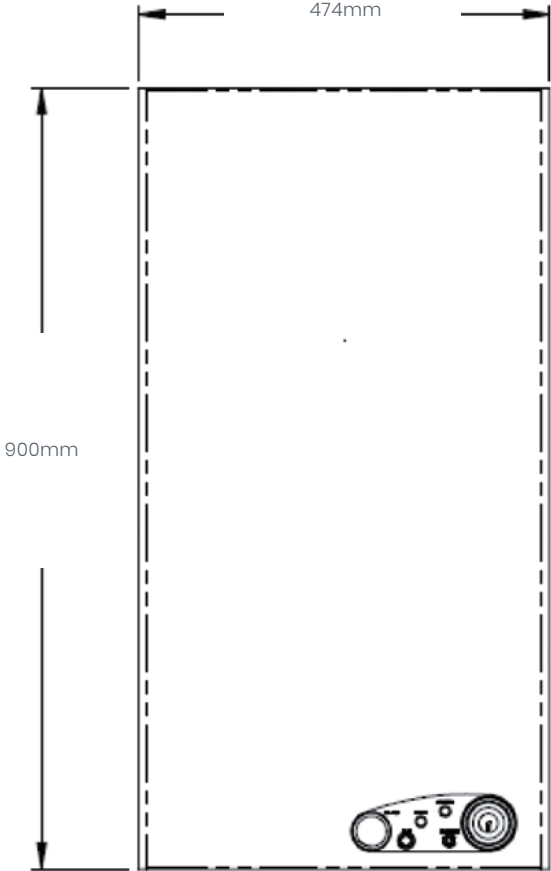

Cross-Sectional View

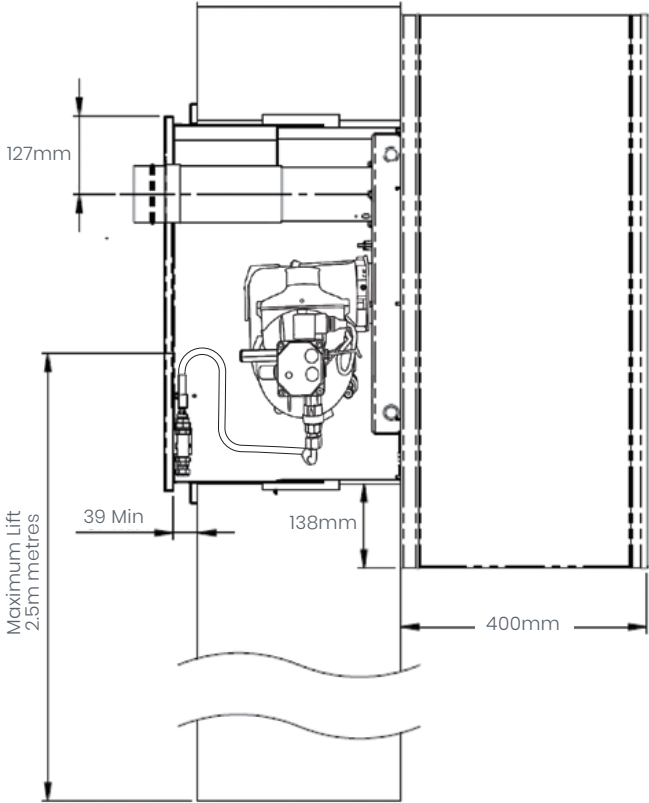

External View

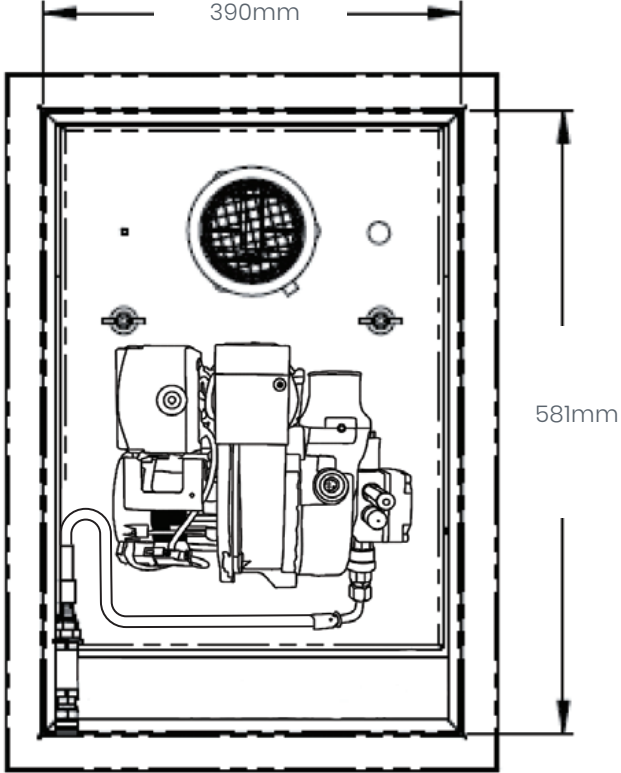



FHWS 1

The FHWS 1 is the latest version of FHWS range which has now been in production for 20 years. Unrivalled with its high efficiency, space saving design and quiet, odourless operation while retaining the original FHWS ease of installation and servicing. Supplied complete with an integrated Balanced Flue, the FHWS1 is available in a 12-16kW output.

Inside Casing

H 600mm W 400mm D 310mm

Outside Casing

H 500mm W 330mm D Telescopic

Key Benefits

- ✓ Space Saving
- ✓ Eliminates Odours
- ✓ Quieter
- ✓ Integral Balanced Flue
- ✓ Single Pipe Oil Supply
- ✓ 2 Year Parts & Labour Warranty
- ✓ 5 Years On The H/EX

Pipework Data

- ✓ Heating Flow & Return : 1" BSP
- ✓ Drain Socket : 0.5" BSP
- ✓ Fuel : Class C2 (28 Sec Kerosene)
- ✓ Fuel Connection : 10mm
- ✓ Condensate Drain : 20mm

General Data

- ✓ Telescopic Flue & Wall Duct Range : 210-340mm
- ✓ Suitable For Use On Fully Pumped Indirect Sealed Or Open Vented Systems.
- ✓ Manual Reset High Limited Thermostat Is Fitted As Standard.
- ✓ Frost Thermostat Is Fitted As Standard.
- ✓ Max Installation Height : 2.5m From Tank Outlet To Bottom Of Casing.
- ✓ Oil Filter, Non-Return Valve, Condensate Trap Included.



FREE
me, going
KITU
E

FINEST SELECTION OF
Herbs
& Spices

FHWS 1

Specifications

Product Code	FHWS1
Number of Bedrooms	1, 2
Number of Bathrooms	1, 2
Heating System	Open Vented, Sealed
Condensate Drain	20mm
Condensate Trap	Included
Drain Socket	0.5" BSP
Flow and Return	1" BSP
Frost Thermostat	Included
Fuel	Class C2 (28 Second Kerosene)
Fuel Connection	10mm

Technical Information

	12kW	14kW	16kW
Nozzle	0.45 80° EH	0.5 80° EH	0.5 80° EH
Oil Pressure	100 PSI	100 PSI	120 PSI
CO ²	12% +/-1%	12% +/-1%	12% +/-1%
Inner Adjustment Assembly	No. 5	No. 5	No. 5

Integrated Balanced Flue	Included
Manual Reset High Limit Thermostat	Included
Max installation height	2.5 meters from Tank Outlet
Non-return Valve	Included
Oil Filter	Included
Output	12-16kW
Telescopic Flue & Wall Duct Range	210-340mm (W1CX100 +100mm Extension Kit available)
Tigerloop / Deareator	Not required
Warranty	2 years parts and labour 3 additional years on Water Jacket

Internal View

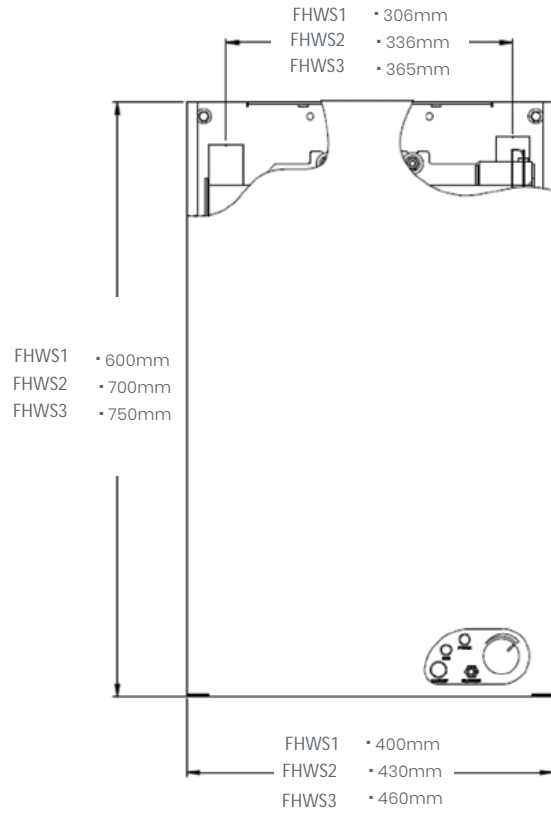

Cross-Sectional View

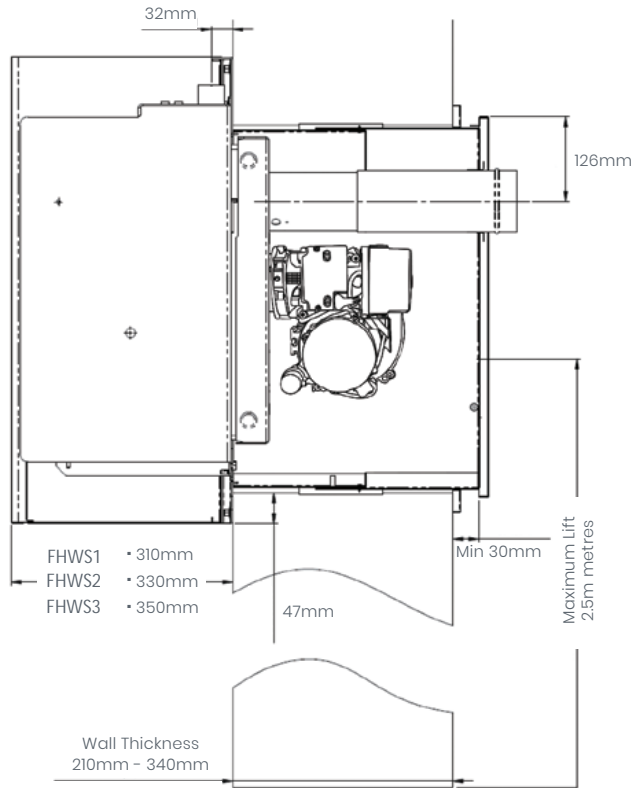

External View

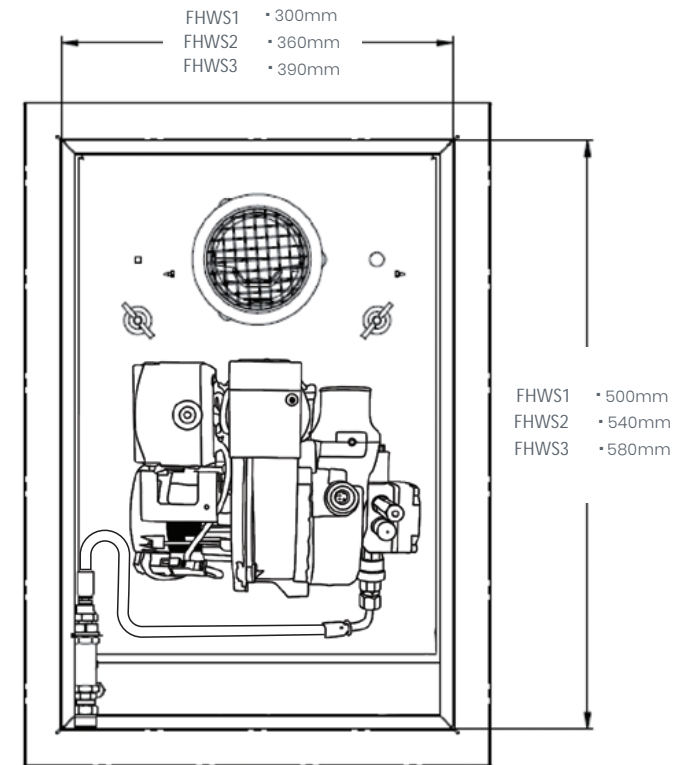

FHWS 2

Unrivalled with its high efficiency, space saving design and quiet, odourless operation while retaining the original FHWS ease of installation and servicing. Supplied complete with an integrated Balanced Flue, the FHWS2 is available in a 12-20kW output.

Inside Casing

H 700mm W 430mm D 330mm

Outside Casing

H 540mm W 360mm D Telescopic

Key Benefits

- ✓ Space Saving
- ✓ Eliminates Odours
- ✓ Quieter
- ✓ Integral Balanced Flue
- ✓ Single Pipe Oil Supply
- ✓ 2 Year Parts & Labour Warranty
- ✓ 5 Years On The H/EX

Pipework Data

- ✓ Heating Flow & Return : 1" BSP
- ✓ Drain Socket : 0.5" BSP
- ✓ Fuel : Class C2 (28 Sec Kerosene)
- ✓ Fuel Connection : 10mm
- ✓ Condensate Drain : 20mm

General Data

- ✓ Telescopic Flue & Wall Duct Range : 210-340mm
- ✓ Suitable For Use On Fully Pumped Indirect Sealed Or Open Vented Systems.
- ✓ Manual Reset High Limited Thermostat Is Fitted As Standard.
- ✓ Frost Thermostat Is Fitted As Standard.
- ✓ Max Installation Height : 2.5m From Tank Outlet To Bottom Of Casing.
- ✓ Oil Filter, Non-Return Valve, Condensate Trap Included.





FHWS 2

Specifications

Product Code	FHWS2
Number of Bedrooms	3, 4
Number of Bathrooms	1, 2, 3
Heating System	Open Vented, Sealed
Condensate Drain	20mm
Condensate Trap	Included
Drain Socket	0.5" BSP
Flow and Return	1" BSP
Frost Thermostat	Included
Fuel	Class C2 (28 Second Kerosene)
Fuel Connection	10mm

Technical Information

	12kW	14kW	16kW	18kW	20kW
Nozzle	0.45 80° EH	0.5 80° EH	0.5 80° EH	0.55 80° EH	0.65 80° EH
Oil Pressure	100 PSI	100 PSI	120 PSI	125 PSI	110 PSI
CO ²	12% +/-1%	12% +/-1%	12% +/-1%	12% +/-1%	12% +/-1%
Inner Adj. Assembly	No. 5	No. 5	No. 5	No. 10	No. 10

Integrated Balanced Flue	Included
Manual Reset High Limit Thermostat	Included
Max installation height	2.5 meters from Tank Outlet
Non-return Valve	Included
Oil Filter	Included
Output	12-20kW
Telescopic Flue & Wall Duct Range	210-340mm (W2CX100 +100mm Extension Kit available)
Tigerloop / Deareator	Not required
Warranty	2 years parts and labour 3 additional years on Water Jacket

Internal View

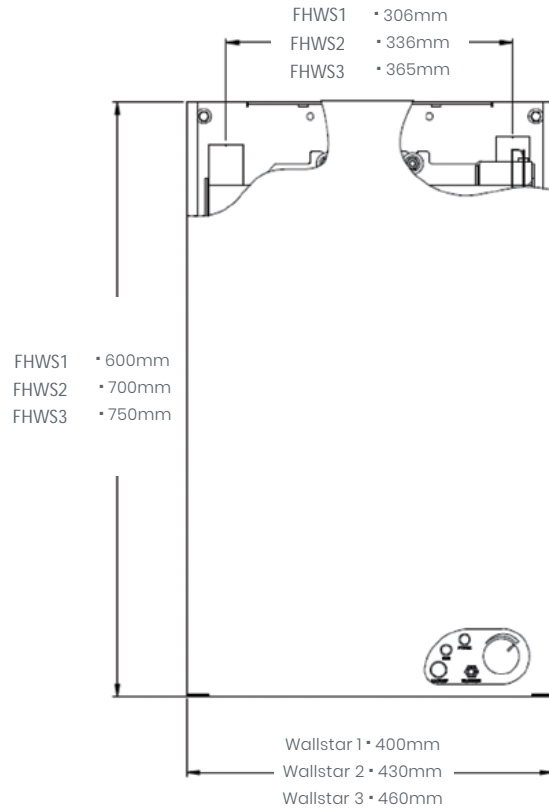

Cross-Sectional View

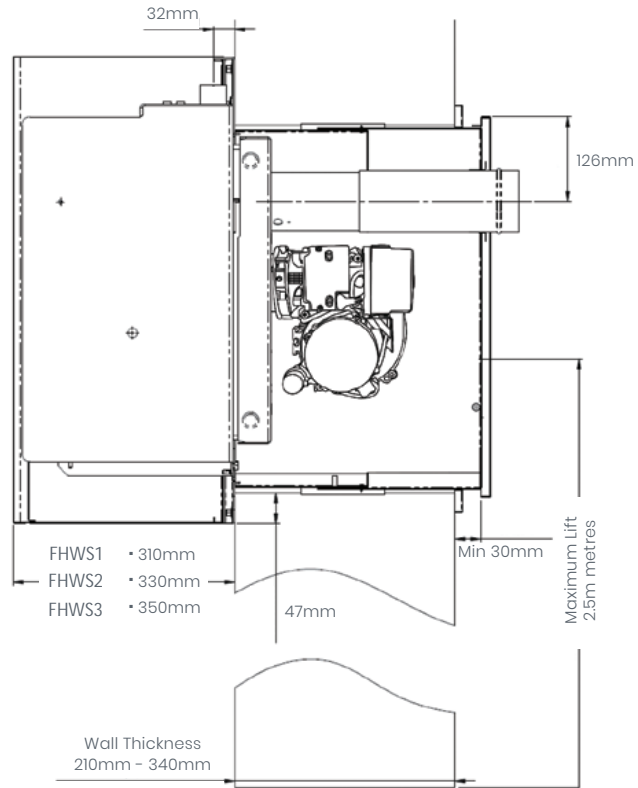

External View

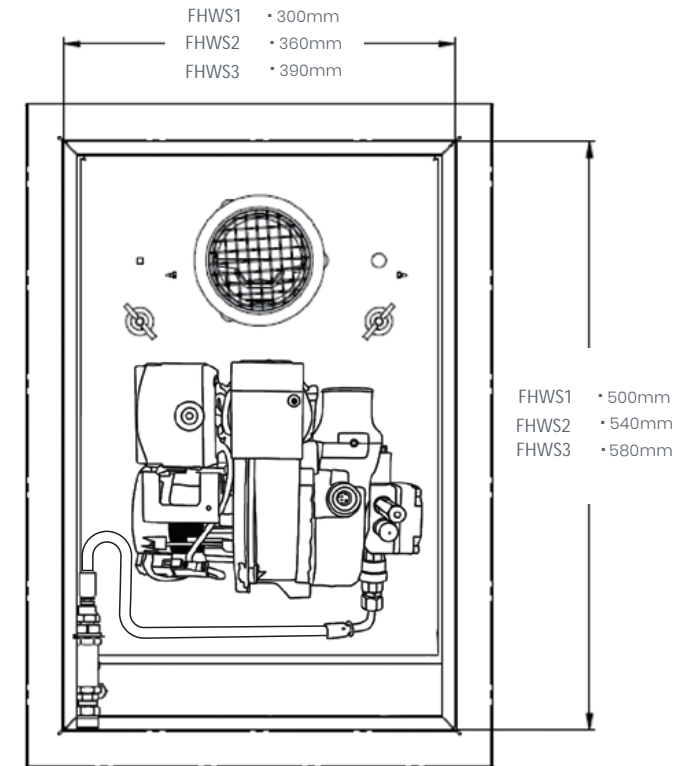



FHWS 3

The FHWS3 is the latest version of The FHWS range which has now been in production for 20 years. Unrivalled with its high efficiency, space saving design and quiet, odourless operation while retaining the original FHWS ease of installation and servicing. Supplied complete with an integrated Balanced Flue, the FHWS3 is available in a 20–24kW output.

Inside Casing

H 750mm W 460mm D 350mm

Outside Casing

H 580mm W 390mm D Telescopic

Key Benefits

- ✓ Space Saving
- ✓ Eliminates Odours
- ✓ Quieter
- ✓ Integral Balanced Flue
- ✓ Single Pipe Oil Supply
- ✓ 2 Year Parts & Labour Warranty
- ✓ 5 Years On The H/EX

Pipework Data

- ✓ Heating Flow & Return : 1" BSP
- ✓ Drain Socket : 0.5" BSP
- ✓ Fuel : Class C2 (28 Sec Kerosene)
- ✓ Fuel Connection : 10mm
- ✓ Condensate Drain : 20mm

General Data

- ✓ Telescopic Flue & Wall Duct Range : 210–340mm
- ✓ Suitable For Use On Fully Pumped Indirect Sealed Or Open Vented Systems.
- ✓ Manual Reset High Limited Thermostat Is Fitted As Standard.
- ✓ Frost Thermostat Is Fitted As Standard.
- ✓ Max Installation Height : 2.5m From Tank Outlet To Bottom Of Casing.
- ✓ Oil Filter, Non-Return Valve, Condensate Trap Included.



FHWS 3

Specifications

Product Code	FHWS3
Number of Bedrooms	4, 5
Number of Bathrooms	2, 3, 4
Heating System	Open Vented, Sealed
Condensate Drain	20mm
Condensate Trap	Included
Drain Socket	0.5" BSP
Flow and Return	1" BSP
Frost Thermostat	Included
Fuel	Class C2 (28 Second Kerosene)
Fuel Connection	10mm

Technical Information

	20kW	22kW	24kW
Nozzle	0.65 80° EH	0.65 80° EH	0.65 80° EH
Oil Pressure	110 PSI	120 PSI	130 PSI
CO ²	12% +/-1%	13% +/-1%	13% +/-1%
Inner Adjustment Assembly	No. 10	No. 10	No. 10

Integrated Balanced Flue	Included
Manual Reset High Limit Thermostat	Included
Max installation height	2.5 meters from Tank Outlet
Non-return Valve	Included
Oil Filter	Included
Output	20-24kW
Telescopic Flue & Wall Duct Range	210-340mm (W3CX100 +100mm Extension Kit available)
Tigerloop / Deareator	Not required
Warranty	2 years parts and labour 3 additional years on Water Jacket

Internal View

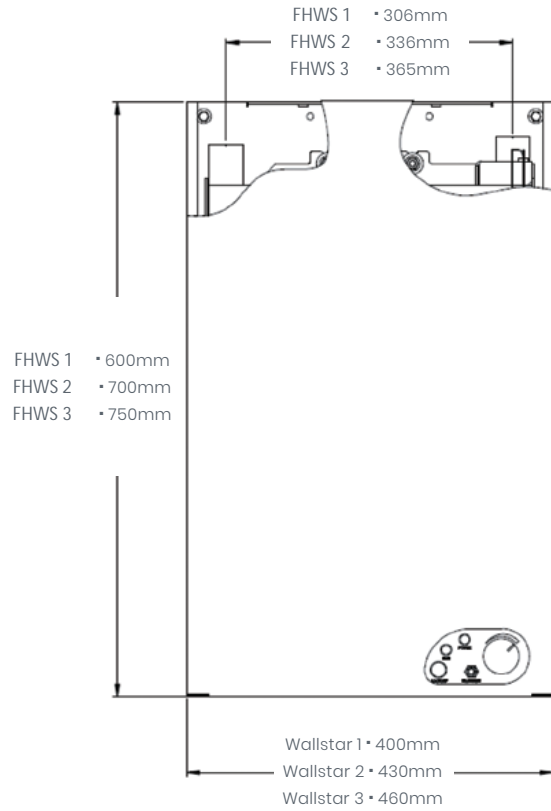

Cross-Sectional View

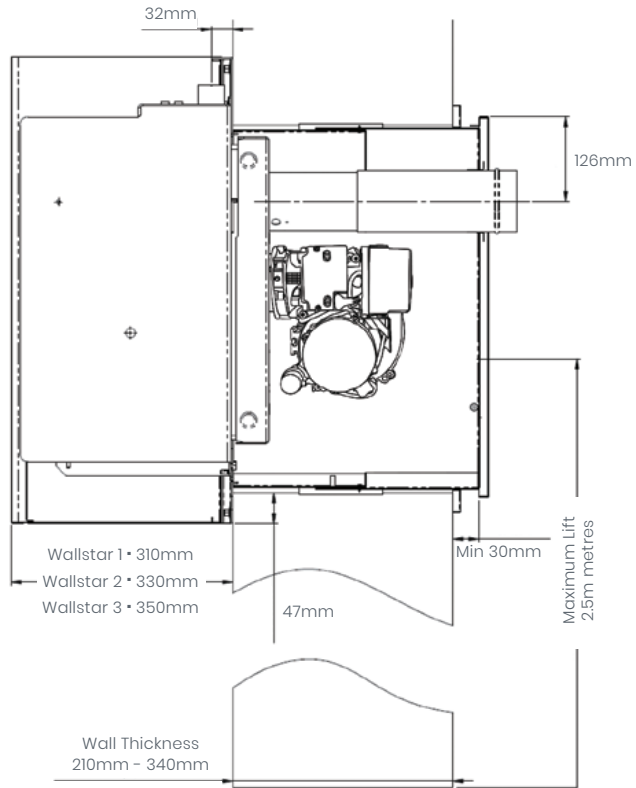

External View

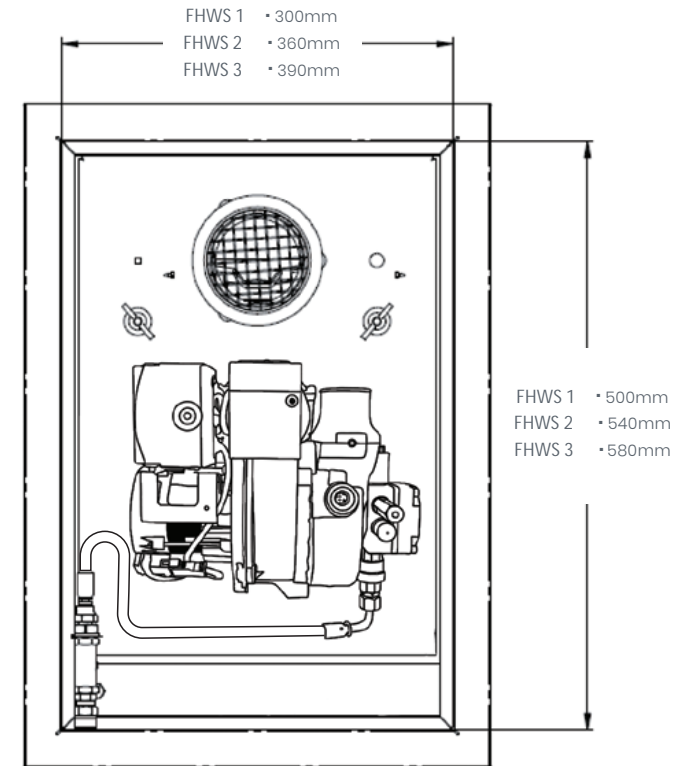



FHWS SYSTEM

The FHWS SYSTEM sealed system boiler is based on the regular FHWS model, but with the circulating pump, expansion vessel and safety valve conveniently located within its casing. The System Wallstar model is available in a 12-20kW output and has all the distinct benefits of the regular Wallstar.

Inside Casing

H 825mm W 446mm D 330mm

Outside Casing

H 540mm W 360mm D Telescopic

Key Benefits

- ✓ Space Saving
- ✓ Eliminates Odours
- ✓ Quieter
- ✓ Integral Balanced Flue
- ✓ Single Pipe Oil Supply
- ✓ 2 Year Parts & Labour Warranty
- ✓ 5 Years On The H/EX

Pipework Data

- ✓ Heating Flow & Return : 1" BSP
- ✓ Drain Socket : 0.5" BSP
- ✓ Fuel : Class C2 (28 Sec Kerosene)
- ✓ Fuel Connection : 10mm
- ✓ Condensate Drain : 20mm

General Data

- ✓ Telescopic Flue & Wall Duct Range : 210-340mm
- ✓ Suitable For Use On Sealed Systems.
- ✓ Manual Reset High Limited Thermostat Is Fitted As Standard.
- ✓ Frost Thermostat Is Fitted As Standard.
- ✓ Max Installation Height : 2.5m From Tank Outlet To Bottom Of Casing.
- ✓ Oil Filter, Non-Return Valve, Condensate Trap Included.



FHWS SYSTEM

Technical Information

	12kW	14kW	16kW	18kW	20kW
Nozzle	0.45 80° EH	0.5 80° EH	0.5 80° EH	0.55 80° EH	0.65 80° EH
Oil Pressure	100 PSI	100 PSI	120 PSI	125 PSI	110 PSI
CO ²	12% +/-1%	12% +/-1%	12% +/-1%	12% +/-1%	12% +/-1%
Inner Adj. Assembly	No. 5	No. 5	No. 5	No. 10	No. 10

Specifications

Product Code	FHWS System
Number of Bedrooms	3, 4
Number of Bathrooms	1, 2, 3
Heating System	Sealed
Circulating Pump	Grundfos UMP3
Condensate Drain	20mm
Condensate Trap	Included
Drain Socket	0.5" BSP
Expansion Vessel	10 litre
Flow and Return	1" BSP, 22mm End Feed Return
Frost Thermostat	Included
Fuel	Class C2 (28 Second Kerosene)

Fuel Connection	10mm
Integrated Balanced Flue	Included
Manual Reset High Limit Thermostat	Included
Max installation height	2.5 meters from Tank Outlet
Non-return Valve	Included
Oil Filter	Included
Output	12-20kW
Telescopic Flue & Wall Duct Range	210-340mm (W2CX100 +100mm Extension Kit available)
Tigerloop / Deareator	Not required
Warranty	2 years parts and labour 3 additional years on Water Jacket

Internal View

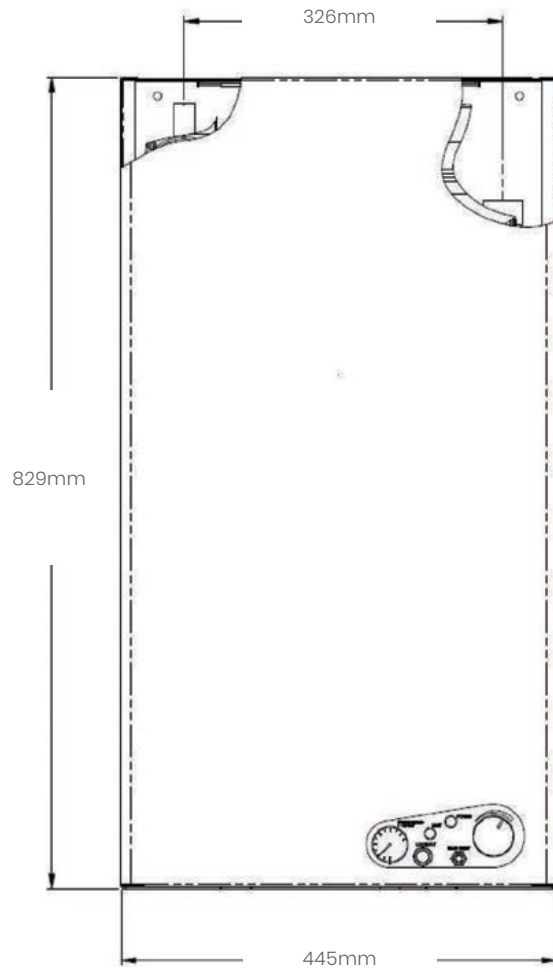

Cross-Sectional View

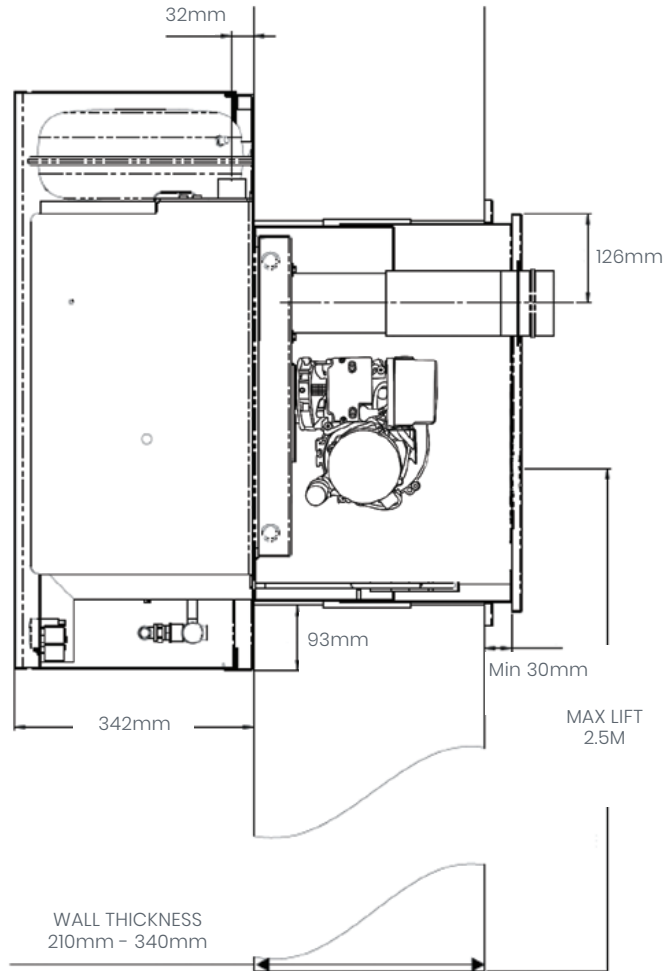

External View

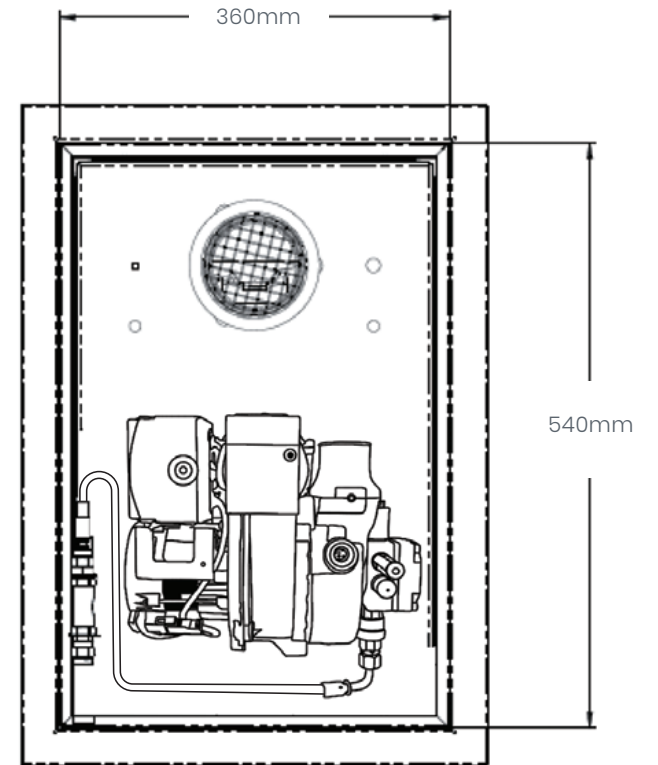



FLEXIHEAT UK LTD

www.flexiheatuk.com

01202 822221

For more information please see our dedicated webpage here –

<https://www.flexiheatuk.com/product/wall-mounted-oil-boilers/>