



Terry
total lift solutions

MELODY 3

Melody 3 Lifting Platform

The Terry Melody 3 Lifting Platform offers an aesthetically pleasing solution to the problem of short-rise vertical wheelchair access outside and inside. The innovative design ensures ease of use and compliance with the current disability legislation.

Standard Specification

Finish: Painted carriage with polycarbonate infills.
 Painted upper level landing gate with polycarbonate infill

Useable platform area: 900mm x 1400mm

Integral ramp: Eliminates the requirement for a pit – minimises building work

Maximum safe working load:
 500 kg up to 2m / 440kg up to 3m

Maximum travel: 3m (3000mm)

Minimum travel: 750mm

Rated speed: 0.08 metres per second

Power supply electrical requirements:
 Dedicated 220/240V AC~ 50/60 Hz 13A single phase
 RCD Protected Supply

Low voltage operating system: 12VDC

Hydraulic oil grade: T22

Operating temperature range: -10°C to +40°C

Safety: Safety surfaces protect against entrapment below the platform. The lift has battery back-up for emergency lowering only. Hose burst valve on the ram. Chequer plate floor.

Lifting mechanism:
 Direct acting hydraulic drive system

IP rating: Control stations IP53X

Corrosion resistant materials (All visible components):
 Aluminium. Polyester Powder Coating applied to either galvanised or zintec steel sheet or active zinc primer.

Design and manufacturing standard:
 2006/42/EC Machinery Directive, (CE Mark),
 and BS6440 (2011).

Available Options

- Powered platform and landing gates
- 1100mm x 1400mm platform
- Dual car controls
- Full battery back up
- Stainless Steel Kit: All handrail posts, kicking strips, platform trims, upper handrail panels and covers
- Pit Installation (indoor installation only)
- Remote Enabler or Remote Isolate (extra fobs available)
- Stand alone call station in post - stainless steel or painted finish
- Wall mounted surface or flush call stations
- Special paint finishes
- Various non-slip vinyl floor coverings
- LED down lights
- GPRS autodialler for 2-way voice communication

Melody 3 Dimensions (in mm)

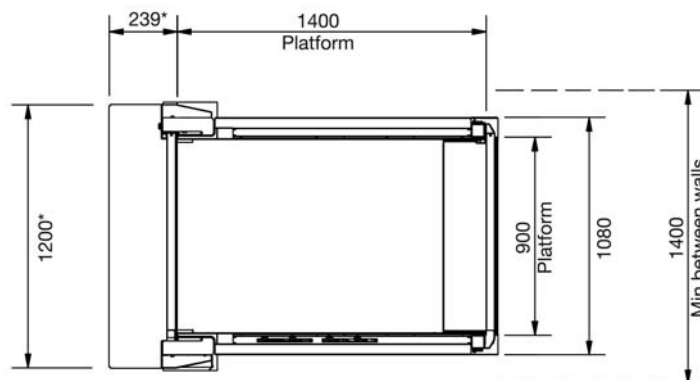

* Upper level fixing plate

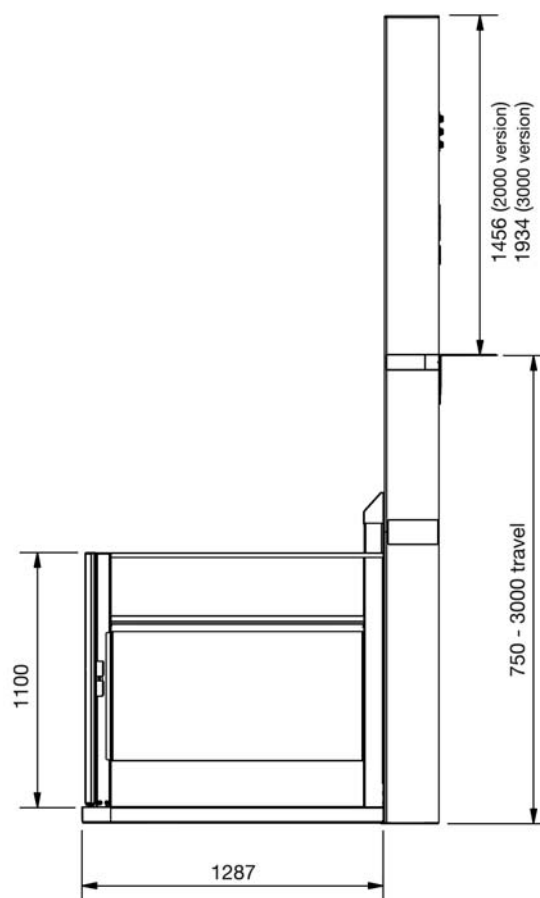

Call us today on: **0345 365 5366**
 or e-mail: **sales@terrylifts.co.uk**



Terry
 total lift solutions

Terry Group Ltd. Longridge Trading
 Estate, Knutsford, Cheshire, WA16 8PR
 tel (outside UK): 00 44 (0)1565 650376
 www.terrylifts.co.uk

