



PRODUCT BROCHURE

VENTILATION SOLUTIONS

INNOVATIVE
PARTNER



PRODUCT BROCHURE

VENTILATION SOLUTIONS



VENTILATION SOLUTIONS

Hybalans+ EPS	4
Hybalans+ vapour-tight roof cover plate	5
Advantages of Hybalans+	6
Hybalans+ round, 92 and 75 mm	10
Hybalans+ oval	17
Air valves	20
Filter	21
Other ventilation systems	22
Insulated ducting, roof and wall outlet terminals	23
Accessories	27
Practical examples	29
Layout suggestions	30
Notes	32

AIR DISTRIBUTION SYSTEM

Hybalans+ EPS

Unique, insulated Ø125 and Ø160 ducting for the perfect connection of heat recovery (HR) and mechanical ventilation (MV) systems. The smart construction and high insulation value prevent condensation in the pipes and minimise energy loss of the ventilation air.

We proudly present our completely new insulated HR ducting system. Our successful existing products have now been supplemented by an economy range.

The new range of insulated ducts is suitable for the supply and exhaust of ventilation air in homes and small public utility buildings. The products are suitable for use inside the home. Made of high-grade insulation material, these products have an extremely high insulation value. The material is lightweight, is easy to cut and fits standard M&G wall and roof terminals. The high insulation value prevents condensation on the ducts at low outside temperatures. As a result, the system can be applied without any concerns.

The development of the new EPS system also included a redesign of the joining of the parts to meet all current and future installation requirements. Both ventilation units and installation areas are getting smaller, and the demand for systems mounted more closely to the wall is increasing. The new, smart couplers guarantee an airtight connection and ensure that ducts can be mounted close together or directly against the wall while retaining their high insulation value.

Characteristics:

- High insulation value $\lambda = 0.032 \text{ W/mK}$
- High fire resistance: Class E (EN 1501-1)
- Air tightness: Class D (EN 13180)
- Improved construction suitable for compact installations
- Lightweight and easily cut
- No thermal bridge due to smart construction
- Specific 45-degree bend for ideal flow

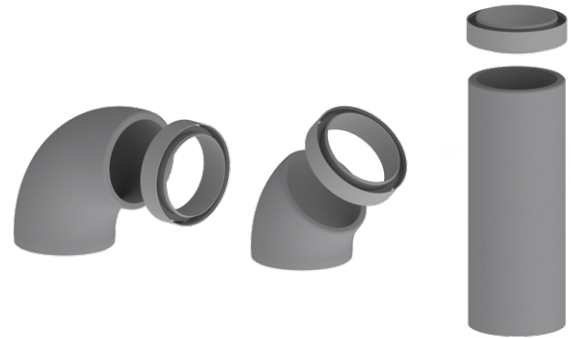

Delivery programme:

Component	Ø 125	Ø 160
1 metre extension pipe	✓	✓
0.5 metre extension pipe	✓	✓
45° bend	✓	✓
90° bend	✓	✓
Coupling unit	✓	✓
Mounting bracket	✓	✓

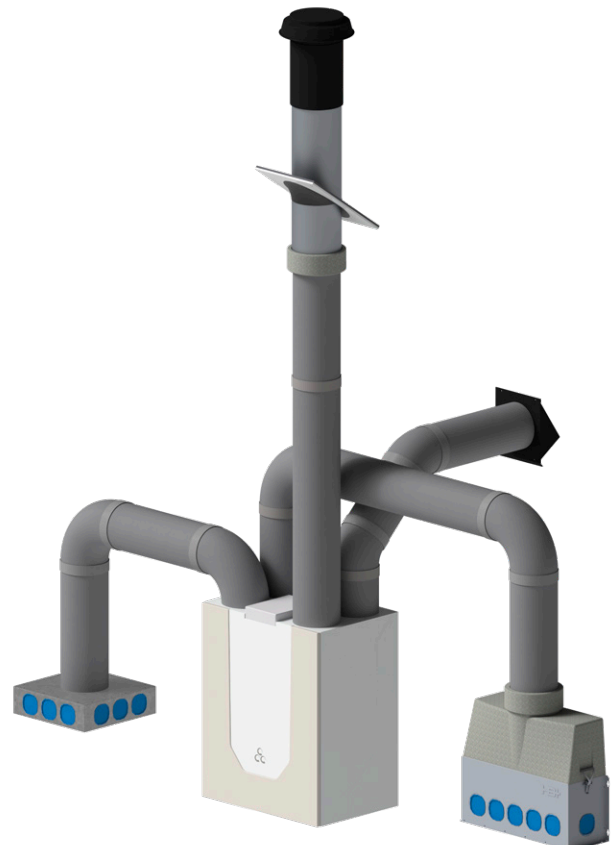

Hybalans+ vapour-tight roof cover plate

Vapour-tight roof cover plate, the ideal solution for airtight and energy-efficient construction

Supplementary to our extensive programme of roof terminals, M&G Group has developed a new range of vapour-tight roof cover plate. This new range of vapour-tight roof cover plates is ideal for sealing roof terminals when using our terminals.

Vapour-tight construction is the ideal way to lower a home's energy bill. The airtightness requirements of houses are so important that they have been defined in the Buildings Decree. Our new programme of vapour-tight roof terminals is perfectly in line with our programme of insulated ducts conduit and enables you to meet the highest leak-tightness requirements in existing as well as new houses.

- Vapour-tight and aesthetic under-roof solution
- The flexible sleeve creates a vapour-tight seal to supplement our programme of insulated ducts
- No moisture or condensation penetration to the roof structure
- No draught along the lead-through, which prevents condensation (no thermal bridge)
- Because of its smart dimensions, the roof board can be used with roof pitches from 0 to 60 degrees.
- Various designs available for all common roof pitches and lead-through diameters

The flexible sleeve meets the highest airtightness class for energy-efficient and airtight construction.

The robust steel washer plate ensures a reliable seal with the roof boarding.

The roof board is easy to attach using the screws supplied and is suitable for indoor applications.

Characteristics:

- Durable elastic sleeve suitable for several different diameters
- Robust steel washer plate
- Proven airtightness (DIN12114 up to 1000 Pa)
- High insulation value up to $\lambda = 0.034 \text{ W/mK}$
- Suitable for roof pitches from 0-60°
- Suitable for pipe diameters from 94 to 302 mm
- Colour of washer plate: RAL White 9016

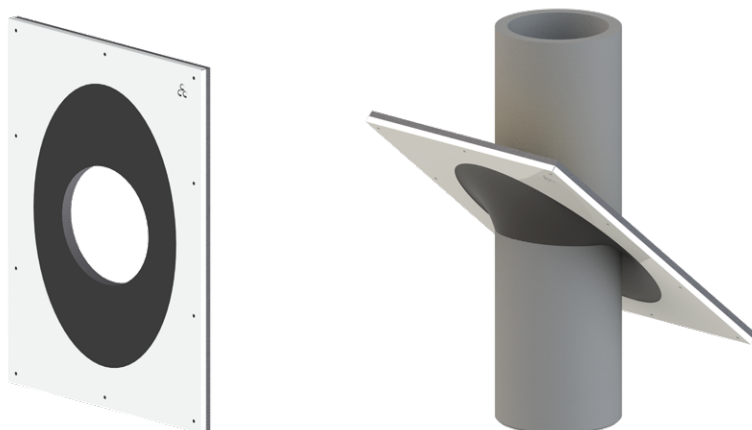

AIR DISTRIBUTION SYSTEM

100% successful air distribution

Flawless transition to a healthy indoor climate

Hybalans+ from M&G Flues is a revolutionary air distribution system for all ventilation problems.

It is easy to design and to assemble, and unfailingly provides superior well-ventilated comfort that will last.

Hybalans+ has nothing but advantages to offer commissioners of work, architects, advisors and fitters. Now available in three different versions!

Five unique advantages

1. Maximum freedom of design and flexibility

- Modular system: the manageable number of components takes the hassle out of designing widely varying air distribution systems.
- Unbelievably flexible: changes can easily be implemented into the design to accommodate changes made to the building, without sacrificing quality.

2. Maximum comfort from all types of ventilation systems

- Comfort assured: the simplicity of the system ensures perfectly regulated air distribution and a healthy indoor climate.
- No draughts: special inlet air valves provide a gentle flow of fresh air.
- No acoustic transference: keeping the ducts for each room separate eliminates 'cross-talk'.
- Exceptionally quiet: thanks to the acoustic dampers in the air distribution manifolds and the smooth plastic connections.

3. Energy-efficient and durable

- Aerodynamic design: minimum ventilator power requirement, thanks to revolutionary low air resistance, means super energy efficiency.
- Durable quality: smart, computer-aided design provides optimum air circulation through the entire system, ensuring constant high quality.

4. Time-saving assembly

- Quick and easy assembly - no tools, no adhesives: thanks to snap connectors between the air distribution manifold, the flexible ducting and the air valves.
- No modifications needed: the floor retains its structural integrity, it does not usually need to be disturbed even when two ducts must cross.
- No post-assembly adjustment of air valves necessary: just fit the correct size of restriction ring as indicated by the Hybalans+ calculator on www.mg-flues.com.

5. Minimum maintenance costs

- Very little maintenance required: intelligent design prevents fouling of ducting and loss of pressure.
- Easy to clean: air valves and ducts can easily be cleaned, without the risk of disturbing adjustment settings; no unexpected extra costs.
- Limited number of components: practical benefits for stock management, transport and assembly.

AIR DISTRIBUTION SYSTEM

Simple plug-and-play system

Problem-free installation, efficient ventilation

Hybalans+ is a clever plug-and-play system whose results are known beforehand. Hybalans+ is as simple as it is efficient:

- Step 1** Each room has its own red duct for the extraction of stale air and, if desired, its own blue duct for the in-flow of fresh ventilation air.
- Step 2** The flexible plastic ducting, with a standard diameter, is connected up to an air distribution manifold which is, in turn, connected to the chosen ventilation system.
- Step 3** Each duct connected to the air distribution manifold is fitted with a snap-on restriction ring that determines the in-flow of air into the room in question.

The correct in-flow can be calculated quickly and easily using the Hybalans+ calculator on www.mg-flues.com

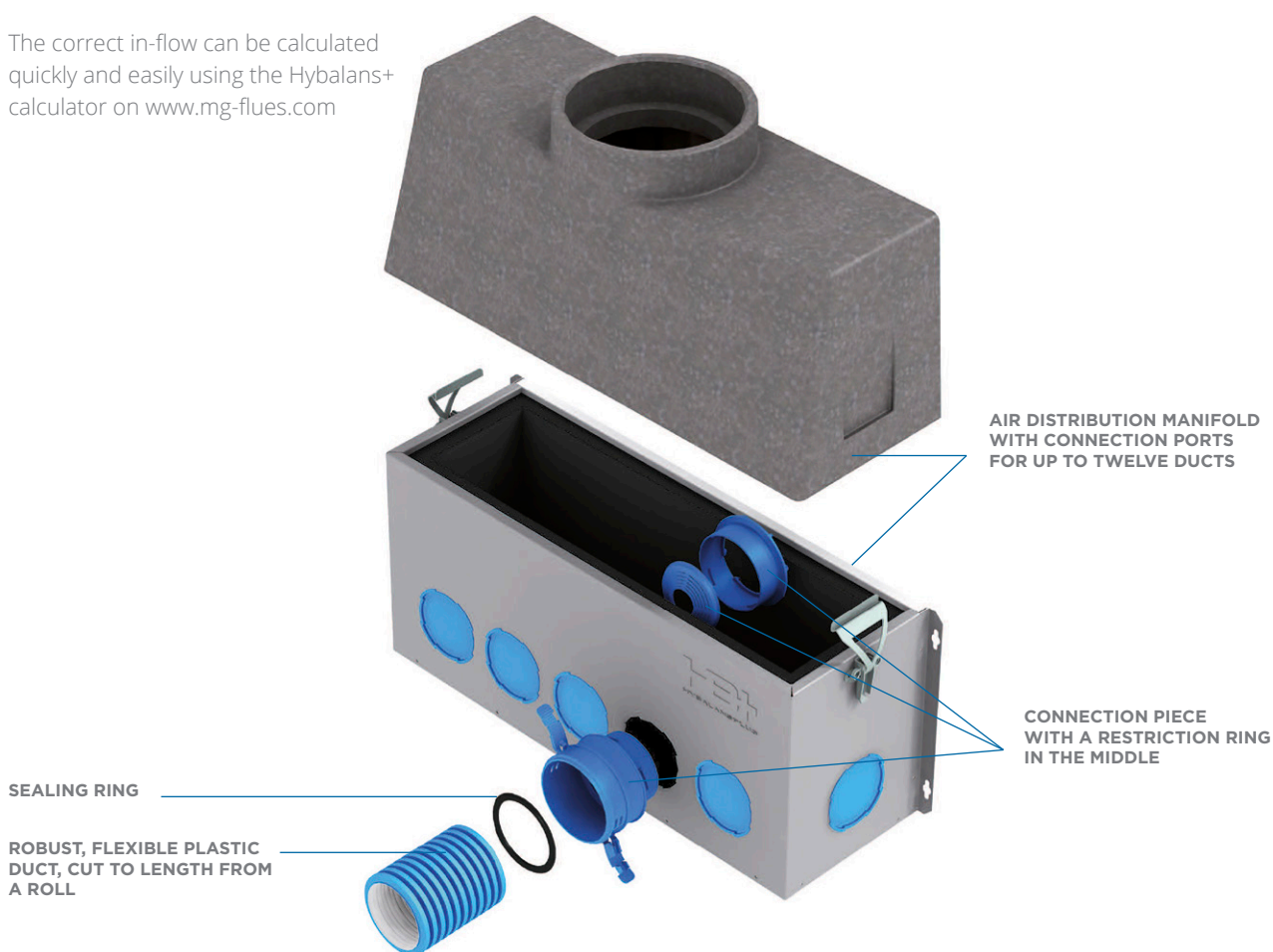

Eliminates confusion

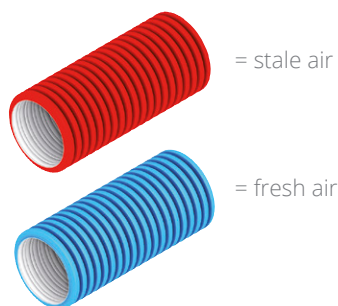

Foolproof adjustment

- Connected = adjusted!
- Online calculator determines the correct size of restriction ring
- Post-assembly adjustment unnecessary
- Adjustment cannot be disturbed during cleaning

Also available in oval version

Only 52 mm high

The preferred option is round Hybalans+ ducting, but there are situations when a flatter solution is required. In such cases you will of course want to work with the trusted Hybalans+ brand and take advantage of its many benefits. For that reason, this entire system is also available in an oval version. The oval ducting is exceptionally flat: only 52 mm.

Fits anywhere

The oval Hybalans+ system is suitable for mounting on or under floors and in cavity and stud walls. It is the ideal solution for screed floors, suspended ceilings and wall systems. Some suggestions for layout can be found on page 88.

The red and blue ducting is also available in oval format

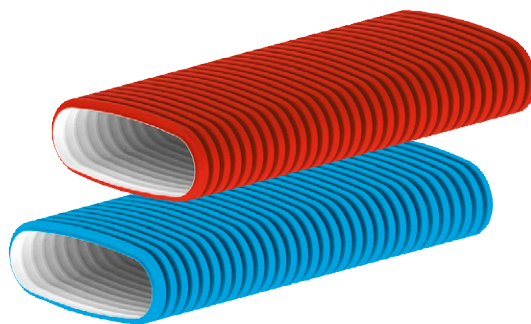

Round and oval ducting can be connected with the aid of an adapter



The oval system has two types of right-angle bends: horizontal and vertical



AIR DISTRIBUTION SYSTEM

Round, 92 and 75 mm

Mechanical air supply plus extraction of stale air

You can recognize Hybalans+ from the blue ducting for the supply of fresh air to an individual room and the red ducting for the extraction of stale air from an individual room. There is no confusion possible!

The simplicity of the system ensures quick and error-free assembly. Thanks to the rugged snap connectors, no tools or adhesives are necessary. Connected is adjusted! Online Hybalans+ calculator determines the correct size of restriction ring. No further adjustment is necessary, and the settings cannot be accidentally disturbed. Page 62 offers a summary of the unique advantages of Hybalans+.

Guide

Components for round Hybalans+ system D: pages 66 to 72 and 76 to 77. Components for oval Hybalans+ system D: pages 73 to 75 and 76 to 77. Insulated ventilation ducting and roof terminals: pages 80 to 82.

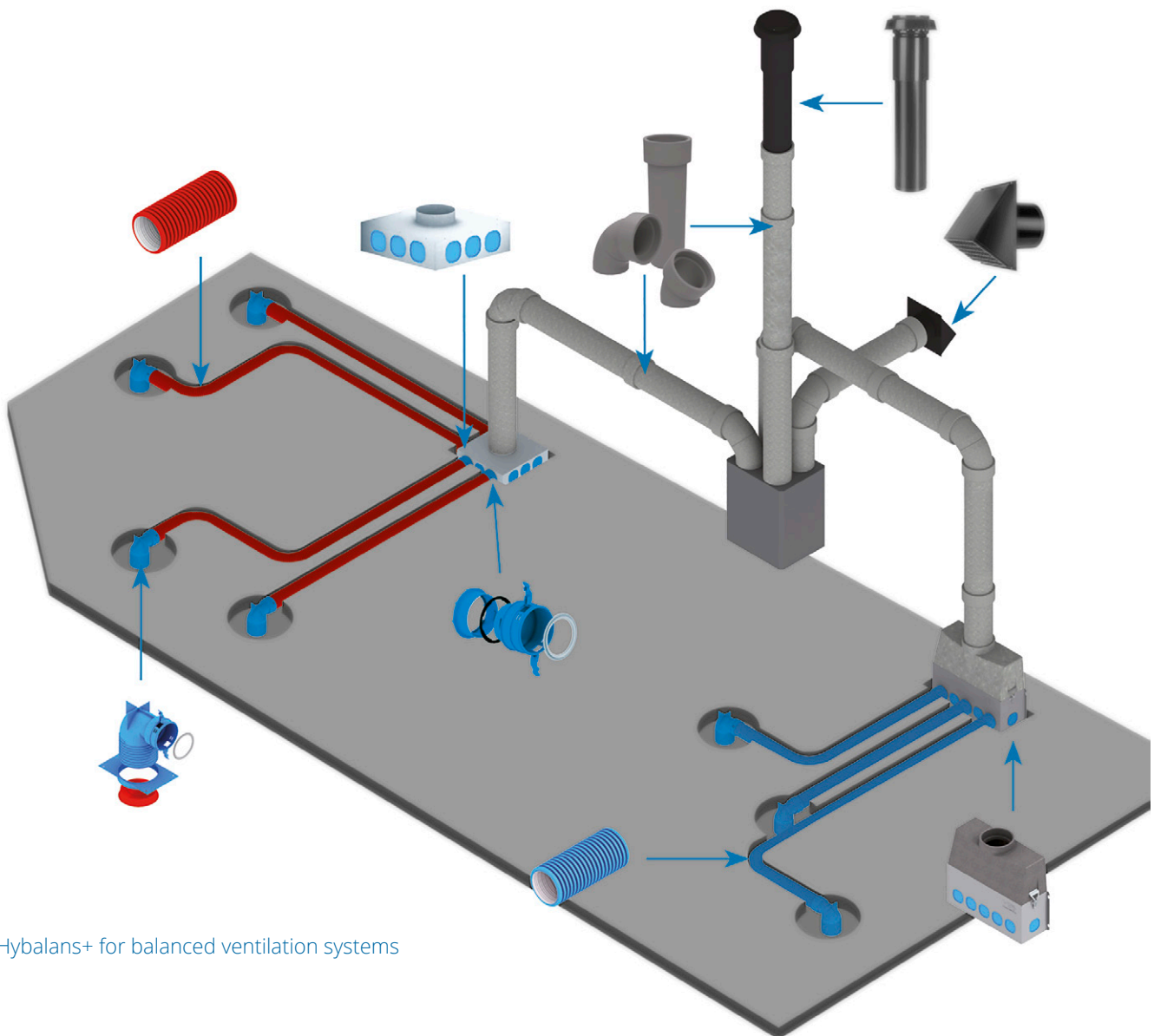

Hybalans+ for balanced ventilation systems

Flexible plastic ducting, supply, blue

This ducting is supplied in 50 meter rolls. The outside is made of corrugated HDPE and the inside is made of smooth LDPE.

Outside Ø (mm)	Inside Ø (mm)	Curve radius (mm)
92	75	150
75	62	120

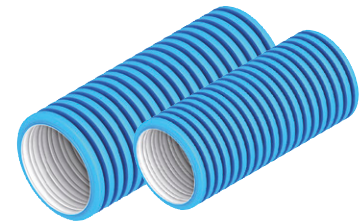

Flexible plastic ducting, extraction, red

This ducting is supplied in 50 meter rolls. The outside is made of corrugated HDPE and the inside is made of smooth LDPE.

Outside Ø (mm)	Inside Ø (mm)	Curve radius (mm)
92	75	150
75	62	120

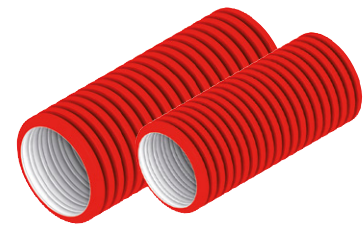

Air extraction plenum, square

The stale air extraction plenum has no internal noise damper and is fitted with a restriction table. There is a Ø 150 mm main connection port; supplied with a cap. The plenum is supplied unpainted.

Dimensions: L x W x H (mm)	Max. out-flow (m ³ /h)	Connection ports
400 x 400 x 110	350	12
300 x 300 x 145	225	8

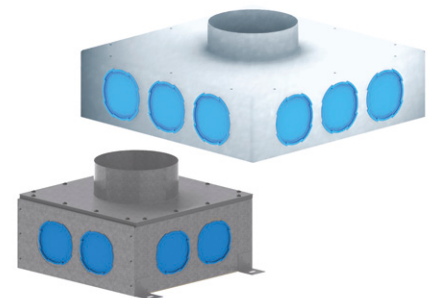

Air extraction plenum, rectangular

The stale air extraction plenum has no internal noise damper and is fitted with a restriction table. There is a Ø 125 mm main connection port; supplied with a cap. The plenum is supplied unpainted.

Dimensions: L x W x H (mm)	Max. out-flow (m ³ /h)	Connection ports
400 x 200 x 110	225	8

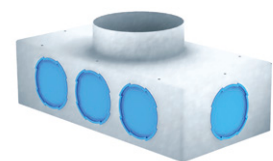

Air distribution manifold complete

The air distribution manifold has an internal noise damper and is fitted with a restriction table. The lower part of the manifold is made of metal, sprayed in a RAL colour. The upper part is made of EPP.

Dimensions: L x W x H (mm)	Max. out-flow (m ³ /h)	Connection ports
603 x 207 x 504	350	12



AIR DISTRIBUTION SYSTEM

Air distribution manifold, upper part

The air distribution manifold is fitted with a pressure plate and must be used in combination with the air distribution manifold lower part. The main connection is suitable for 150 mm and 180 mm EPP ducting or 180 mm metal ducting. The upper part is made of EPP.

Dimensions:	Max. out-flow (m ³ /h)
L x W x H (mm)	
603 x 207 x 233	350



Air distribution manifold, lower part

The air distribution manifold is fitted with a restriction table and must be used in combination with the air distribution manifold upper part. The 350 m³/h version is fitted with an internal noise damper.

Dimensions:	Max. out-flow (m ³ /h)	Connection ports
L x W x H (mm)		
603 x 207 x 271	350	12

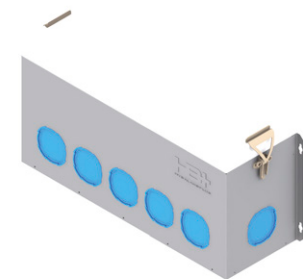

Air distribution manifold lower part {tall version}

The air distribution manifold is fitted with a restriction table and must be used in combination with the air distribution manifold upper part. The 350 m³/h version is fitted with an internal noise damper.

Dimensions:	Max. out-flow (m ³ /h)	Connection ports
L x W x H (mm)		
603 x 207 x 420	350	12



Air supply and/or extraction plenum

The plenum is supplied unpainted. Only for use in combination with right-angle/straight air distribution manifold.

Dimensions:	Max. out-flow (m ³ /h)	Connection ports
L x W x H (mm)		
603 x 207 x 180	450	12
603 x 207 x 110	450	12

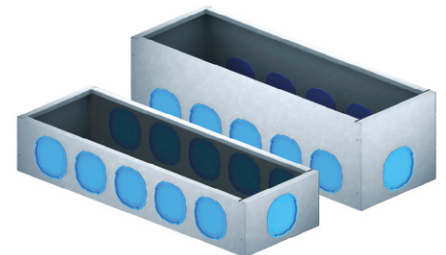

Air distribution manifold, right-angle/straight

The air distribution manifold is supplied with a removable cap and an air distribution manifold intermediate part; it has rotating clip fittings and no internal noise damper. The main connection is suitable for 150 mm and 180 mm EPP ducting or 180 mm metal ducting. The lower part of the manifold is made of metal, sprayed in a RAL colour. The upper part is made of EPP.

Dimensions: L x W x H (mm)	Max. out-flow (m ³ /h)
603 x 207 x 440	450



Wall-mounted plenum for air supply and/or extraction

Height-adjustable plenum with 2 connection ports. The plenum is supplied unpainted. Grille included.

Dimensions: L x W x H (mm)	Max. out-flow (m ³ /h)	Connection ports
310 x 71 x 264-344	100	2

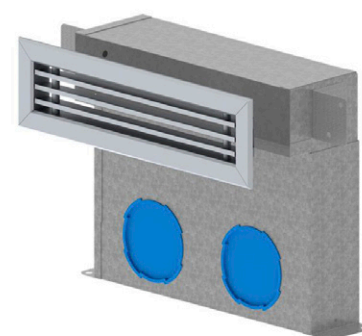

Floor-mounted plenum for air supply and/or extraction

Floor plenum (can be shortened to suit requirements), fitted with 2 connection ports. Upper part: plastic; lower part: unpainted metal. Grille included.

Dimensions: L x W x H (mm)	Max. out-flow (m ³ /h)	Connection ports
327 x 80 x 310	100	2



AIR DISTRIBUTION SYSTEM

Connection piece, complete

The connection piece is fitted with snap connectors, a connection for a restriction ring (not supplied) and has two sealing rings.

Application	Ø (mm)
Air distribution manifold or extraction plenum	92
Air distribution manifold or extraction plenum	75



Connection bend, complete

Application	Ø (mm)
Air distribution manifold or extraction plenum	92
Air distribution manifold or extraction plenum	75



Restriction ring

Calculate the correct opening with the aid of the calculator on www.mg-flues.com.

Application
Fits into connection piece



Air valve connection, right-angle

For Ø 92 mm ducting. The air valve connection piece has snap connectors, a mounting plate which is fully adjustable to the thickness required, a dust cap and a sealing ring.

Application	Max. floor or wall thickness (mm).	Air valve side Ø (mm)	
		inside	outside
Connecting air valve to ducting	100	117	122
	250	125	130



Air valve connection, straight

For Ø 92 mm ducting. The air valve connection piece has snap connectors. It is suitable for floor or wall thicknesses of up to 100 mm.

Application	Air valve side Ø (mm)	
	inside	outside
Connecting air valve to ducting	117	122
	125	130

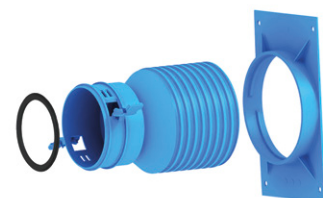

Right-angle bend

The bend is fitted with snap connectors and supplied with two sealing rings.

Application	Ø (mm)
Creating a right-angle connection between two ducts	92
Creating a right-angle connection between two ducts	75



Right-angle bend with mounting base

The bend is fitted with snap connectors and supplied with two sealing rings; it creates a right-angle connection between two ducts.

Application	Ø (mm)
Floor mounting	92
Floor mounting	75



Sleeve joint, straight

The sleeve joint is fitted with snap connectors and supplied with two sealing rings.

Application	Ø (mm)
Connecting two ducts	92
Connecting two ducts	75



Air valve connection, right-angle

This connection piece allows two Ø 75 mm ducts to be connected to a single air valve. Fitted with snap connectors. The connection piece has a fully adjustable mounting base suitable for floor or wall thicknesses of up to 100 mm, and is supplied with a dust cap and sealing ring.

Application	Air valve side Ø (mm)	
	inside	outside
Connecting air valve	117	122
to ducting	125	130



Air valve connection, straight

This connection piece allows two Ø 75 mm ducts to be connected to a single air valve. Fitted with snap connectors. The connection piece has a fully adjustable mounting base suitable for floor or wall thicknesses of up to 100 mm, and is supplied with a dust cap and sealing ring.

Application	Air valve side Ø (mm)	
	inside	outside
Connecting air valve	117	122
to ducting	125	130

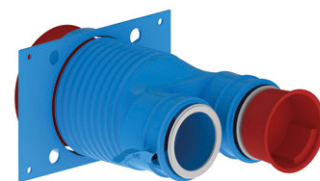

Cross-over, right angles

To allow a cross-over of two 92 mm Ø ducts.

□ (mm)

500

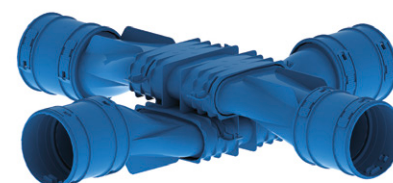

AIR DISTRIBUTION SYSTEM

Sealing ring

Ø (mm)

92

75



Clamping bracket

Galvanized metal clamping bracket with connector.

Application Ø (mm)

To anchor ducting

92

To anchor ducting

75



Spacer

For use with ceiling collar.

Application Length (mm)

For floors thicker than 100 mm

40



Extension piece for air valve connection

The Hybalans+ extractor air valve can be joined directly onto this connection piece.

Application Air valve side Ø (mm) Length (mm)

To extend air valve connection piece

inside

outside

Length (mm)

117

122

60 - 250



Dust cap

Prevents fouling of ducting or components during the construction process. The cap can also be used to label the various ducts.

Application Ø (mm)

Capping the ends of ducts

92

Capping the ends of ducts

75

Capping component 2 x 75

75



For air valves and grilles, see page 76 and 77.

Oval

Flexible plastic ducting, extraction, red

This ducting is supplied in 20 meter rolls. The outside is made of corrugated HDPE and the inside is made of smooth LDPE.

H x W (mm) outside

52 x 132

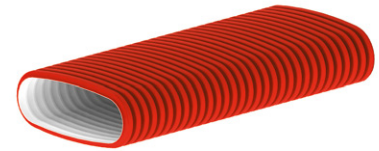

Flexible plastic ducting, supply, blue

This ducting is supplied in 20 meter rolls. The outside is made of corrugated HDPE and the inside is made of smooth LDPE.

H x W (mm) outside

52 x 132

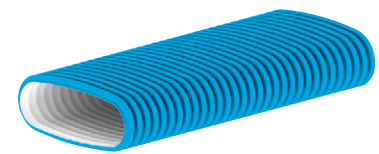

Air distribution manifold, low version, lower part

The air distribution manifold is fitted with a restriction table and must be used in combination with the air distribution manifold upper part.

Dimensions:

L x W x H (mm)	Max. out-flow (m ³ /h)	Connection ports
600 x 210 x 271	350	10



Air distribution manifold, tall version, lower part

The air distribution manifold is fitted with a restriction table and must be used in combination with the air distribution manifold upper part.

Dimensions:

L x W x H (mm)	Max. out-flow (m ³ /h)	Connection ports
600 x 210 x 271	350	10



Air distribution manifold, upper part

The air distribution manifold is fitted with a pressure plate and must be used in combination with the air distribution manifold lower part. The main connection is suitable for 150 mm and 180 mm EPP ducting or 180 mm metal ducting. The upper part is made of EPP.

Dimensions:

L x W x H (mm)	Max. out-flow (m ³ /h)
603 x 207 x 233	350



AIR DISTRIBUTION SYSTEM

Wall-mounted plenum for air supply and/or extraction

Height-adjustable plenum with 2 connection ports. The plenum is supplied unpainted. Grille included.

Dimensions:

L x W x H (mm)	Max. out-flow (m ³ /h)	Connection ports
310 x 71 x 264 - 344	100	2

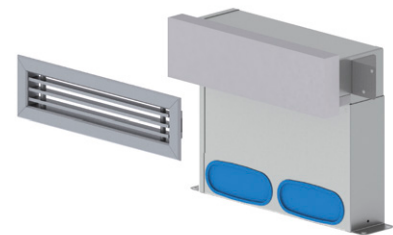

Floor-mounted plenum for air supply and/or extraction

Floor plenum (can be shortened to suit requirements), fitted with 2 connection ports. Upper part: plastic, lower part: unpainted metal. Grille included.

Dimensions:

L x W x H (mm)	Max. out-flow (m ³ /h)	Connection ports
327 x 80 x 310	100	2



Connection bend, vertical right angle

The bend is fitted with snap connectors and supplied with two sealing rings.

Application

Creating a right-angle connection between two ducts



Connection bend, horizontal right angle

The bend is fitted with snap connectors and supplied with two sealing rings.

Application

Creating a right-angle connection between two ducts



Restriction ring

Calculate the correct size of opening with the aid of the calculator on www.mg-flues.com.

Application

Fits into connection piece



Air valve connection, right-angle

The air valve connection piece has snap connectors, a mounting plate which is fully adjustable to the thickness required, a dust cap and a sealing ring. It is suitable for floor and wall thicknesses of up to 100 mm.

Application	Air valve side Ø (mm)	
	inside	outside
Connecting air valve	117	122
to ducting	125	130



Connection piece

The connection piece is fitted with snap connectors and supplied with two sealing rings.

Application

To connect ducting to air distribution manifold

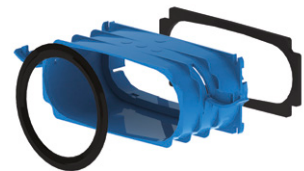

Sleeve joint

The sleeve joint is fitted with snap connectors and supplied with two sealing rings.

Application

To extend ducting



Sleeve joint, oval to round

To connect oval ducting to round ducting.

Application

Transition from round to oval



Sealing ring round/oval

Application

For any component that needs to be fitted with a sealing ring



Dust cap

The dust cap prevents fouling of ducting during the construction process and can also be used to label the various ducts.

Application

Capping the ends of ducts



AIR DISTRIBUTION SYSTEM

Air Valves

Quadrant extraction air valve

Max. out-flow (l/s)	Inside Ø (mm)
21	117
21	125

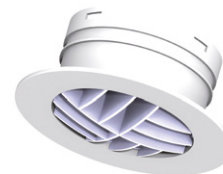

Turn extraction air valve

Max. out-flow (l/s)	Inside Ø (mm)	Louvres
21	117	360° adjustable
21	125	360° adjustable



Cone supply and extraction air valve

Application	Inside Ø (mm)	Max. in-flow (l/s)	Max. out-flow (l/s)
Air supply through wall	117	14	21
Air supply through wall	125	14	21



Disc supply and extraction air valve

Application	Inside Ø (mm)	Max. in-flow (l/s)	Max. out-flow (l/s)
Air supply through wall	117	14	21
Air supply through wall	125	14	21



Cone supply and extraction air valve

Application	Inside Ø (mm)	Max. in-flow (l/s)	Max. out-flow (l/s)
Air supply through wall or ceiling	117	14	21
Air supply through wall or ceiling	125	14	21



Cone supply and extraction air valve

Application	Inside Ø (mm)	Max. in-flow (l/s)	Max. out-flow (l/s)
Air supply through wall or ceiling	117	14	21
Air supply through wall or ceiling	125	14	21



Filter

Filter

To filter the air flowing in to or out of a room.

Application

For placement in air valves

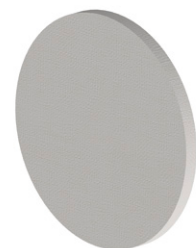

AIR DISTRIBUTION SYSTEM

Other ventilation systems

Air supply or extraction systems

Projects sometimes call for an air supply or extraction system. This requirement can also be fulfilled with Hybalans+ (round or oval). An air supply system is equally suitable for utility buildings and collective systems. The Hybalans+ air supply or extraction system offers many advantages. The clever modular systems ensure that the indoor climate remains healthy. The unparalleled simplicity of the system saves a great deal of time and leads to flawless performance. Components click together without the need for tools or adhesives. The online Hybalans+ calculator helps determine the correct size of restriction ring for the air distribution manifold. Connected is adjusted: no further adjustment is necessary, and the settings cannot be accidentally disturbed. Quality assured.

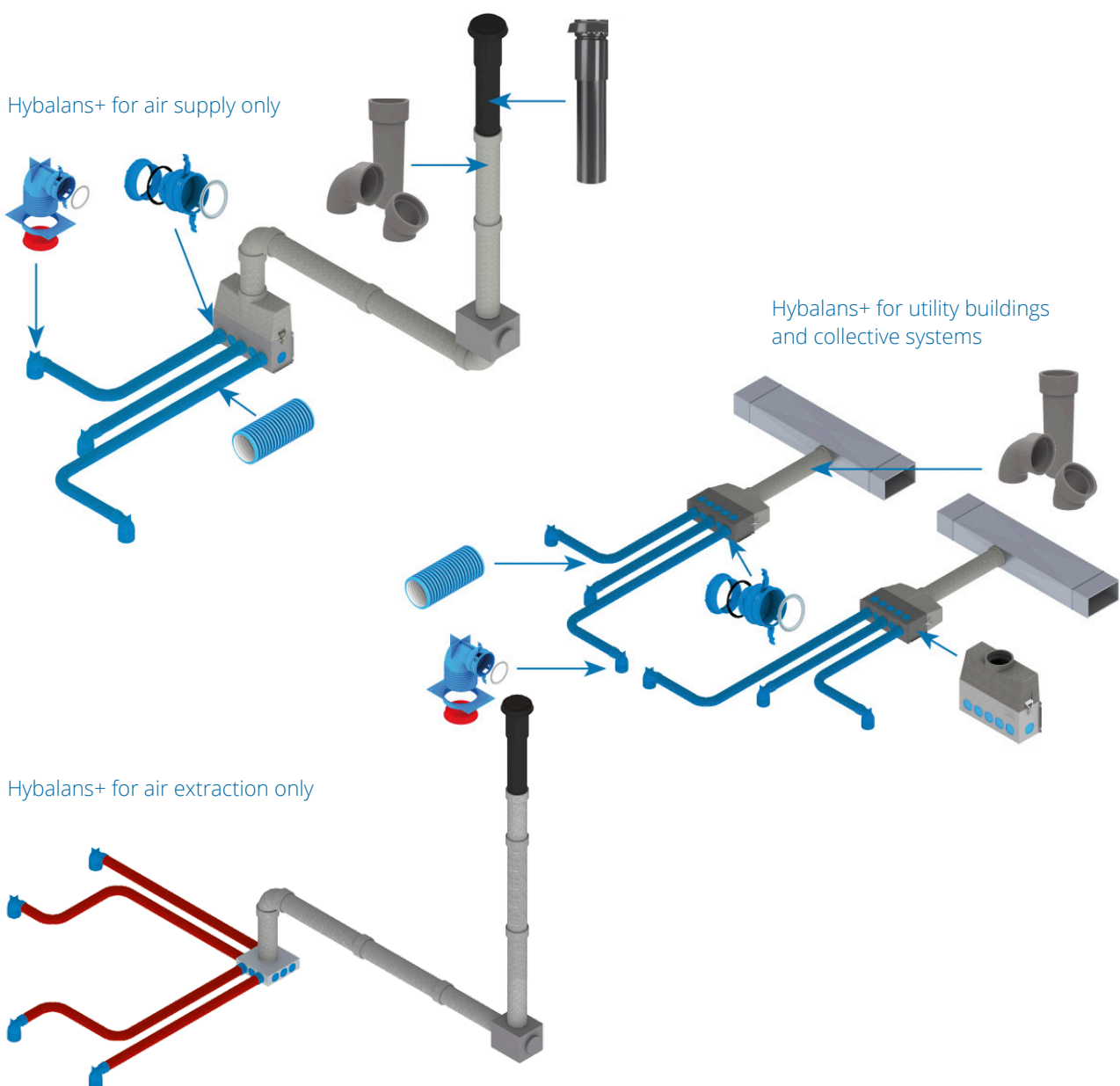

Hybalans+ (round or oval) is also compatible with all boiler manufacturers' specifications.

Insulated ventilation ducting and roof terminals

Use in balanced ventilation system

To prevent in-flowing cold air coming into contact with the warm air inside the building, insulation is used up to the connection point with the heat recovery unit.

Use for air extraction only

Insulation prevents condensation forming at the often cooler place where the warm stale air is vented through the roof.

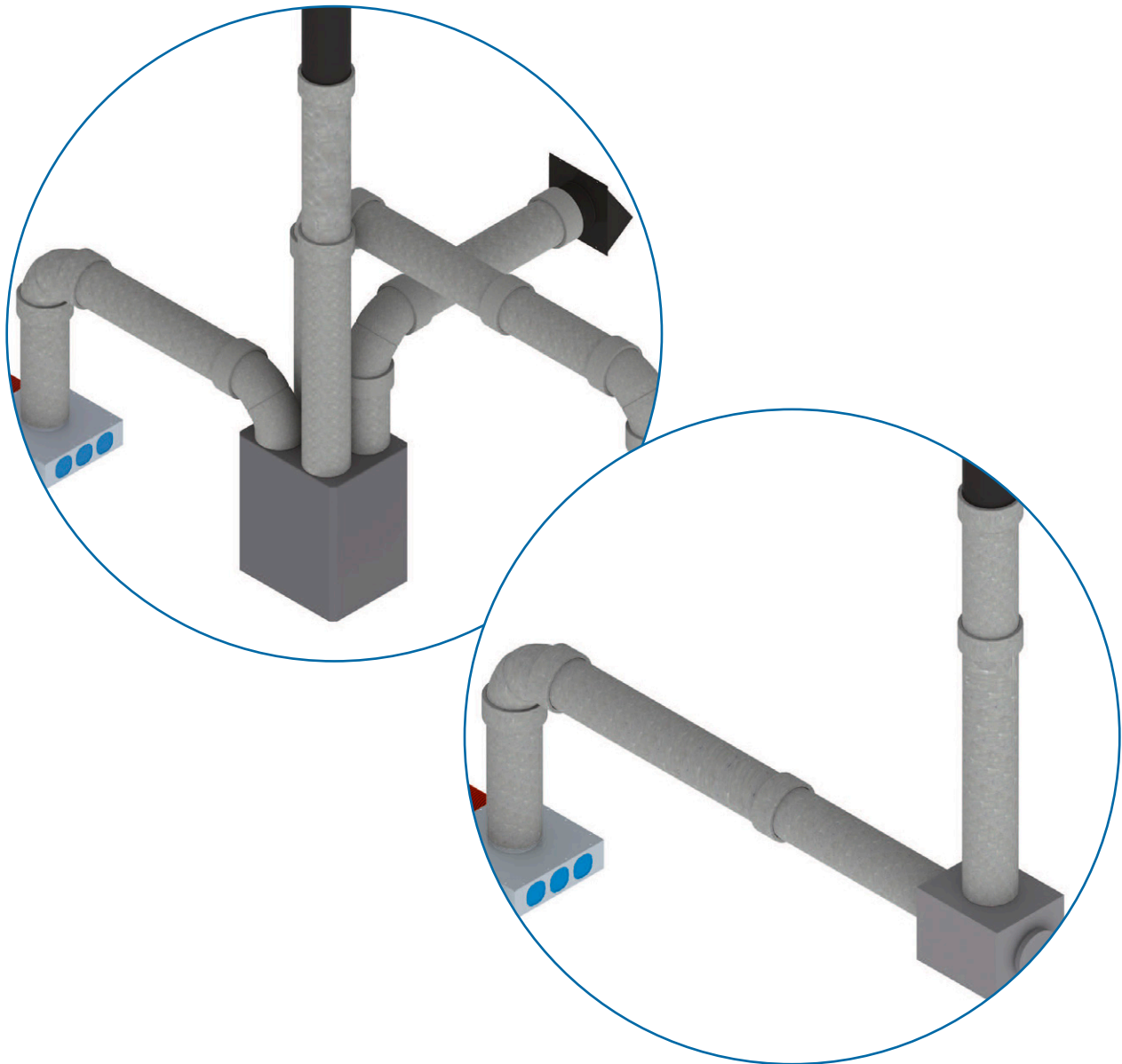

AIR DISTRIBUTION SYSTEM

Insulated ventilation ducting

Insulated ventilation ducting made entirely of EPP. Sleeve joint offers many advantages:

- Creates better connection than plastic PP sleeve joint
- No thermal bridge thanks to excellent insulating value
- Easy to assemble thanks to rounded off edges
- Corrugated inside surface to ensure optimal connection
- Also available in thick-walled version

The right-angle bend is cleverly designed and can be split into two 45° bends quickly and easily by cutting along the marked line.

Just add a separate sleeve joint to the cut ends and both are ready to use.

Also available in thick-walled version for higher grade sound and thermal insulation.

Pipe, including sleeve joint

Ø (mm)	L (mm)
125/150/160/180	500
125/150/160/180	1000



Right angle bend, including sleeve joint

Ø (mm)
125/150/160/180



45° bend, including sleeve joint

Ø (mm)
125/150/160/180

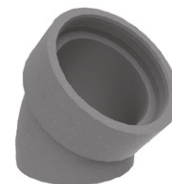

Sleeve joint

Ø (mm)
125/150/160/180

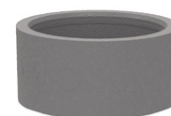

Universal ventilation ducting bracket

Application	Ø (mm)
Thin-walled ventilation ducting	125/150/160/180



Thick-walled pipe, including sleeve joint

Ø (mm)	L (mm)
160/200	1000

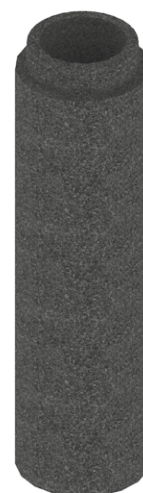

Thick-walled 45° bend, including sleeve joint

Ø (mm)
160/200



Thick-walled sleeve joint

Ø (mm)
160/200



Eccentric reducer

Version (mm)	Reduction (inside-outside diam.)
150	150/160-180/246
160	160/160-190/246
200	180/200-210/286



AIR DISTRIBUTION SYSTEM

Insulated roof ventilation terminals

Roof ventilation terminal 125 mm inside diam. with EPS insulation

Pipe colour	Pipe material	L (mm)
Black	Aluminium	1000

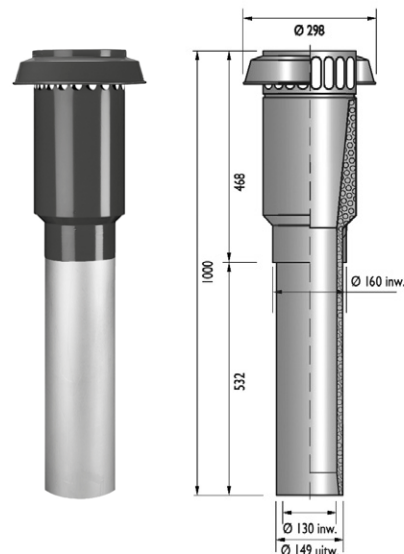

Roof ventilation terminal 150 mm inside diam. with EPS insulation

Pipe colour	Pipe material	L (mm)
Black	Aluminium	989
Black	Aluminium	1750
Terracotta	Aluminium	989

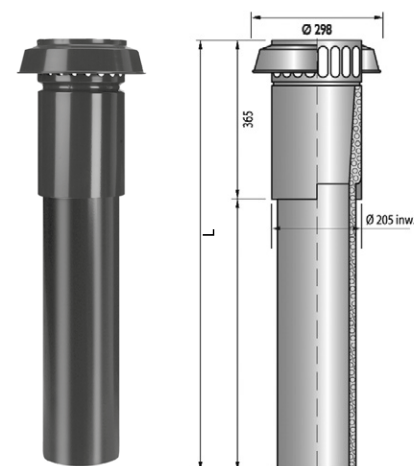

Roof ventilation terminal 160 mm inside diam. with EPS insulation

Pipe colour	Pipe material	L (mm)
Black	Aluminium	989
Terracotta	Aluminium	989

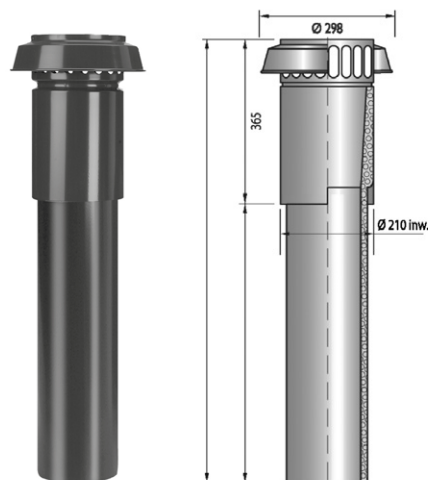

Roof ventilation terminal 180 mm inside diam. with EPS insulation

Pipe colour	Pipe material	L (mm)
Black	Aluminium	989
Black	Aluminium	1675
Terracotta	Aluminium	989

Walloutlet terminals

Wall grill

Colour	Ø (mm)
Black	125/150/160/180/200
White	125/150/160/180/200
Terracotta	125/150/160/180
Unpainted aluminium	125/150/160/180/200



Accessoires

Weather slate, steep roof

Type	Dimensions (mm)	Model
Weather slate, steep roof, non-lead, adjustable	500 x 625	F
Lead flashing, adjustable, standard, incl. adjustable collar F160	500 x 500	F
Lead flashing, adjustable, entirely black	500 x 500	F
Weather slate, steep roof, non-lead, adjustable, incl. adjustable collar D205	800 x 1000	D
Lead flashing, adjustable, incl. adjustable collar D205	800 x 1000	D

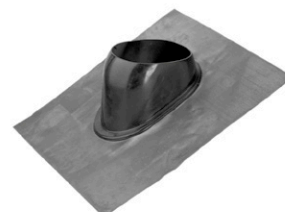
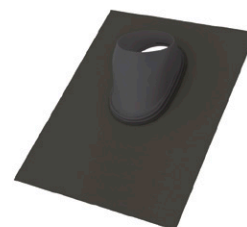

Adjustable collar

Type	Outside Ø (mm)	Color	Type of opening
F 160	159	Black	Insulated ventilation terminal pipe 130 mm
F 160	159	Terracotta	Insulated ventilation terminal pipe 130 mm
D 205	204	Black	Insulated ventilation terminal pipe 150, 160 and 180 mm
D 205	204	Terracotta	Insulated ventilation terminal pipe 150, 160 and 180 mm



AIR DISTRIBUTION SYSTEM

Accessoires

Roof boarding bracket

Ø (mm)	Type of opening	Colour
151	Insulated ventilation terminal pipe 130 mm	Unpainted
181	Insulated ventilation terminal pipe 150 mm	Unpainted
201	Insulated ventilation terminal pipe 160 and 180 mm	Unpainted



Weather slate, flat roof, aluminium, adhesive base

Ø (mm)	Type of opening
160	Insulated ventilation terminal pipe 130 mm
204	Insulated ventilation terminal pipe 150, 160 and 180 mm



Practical examples

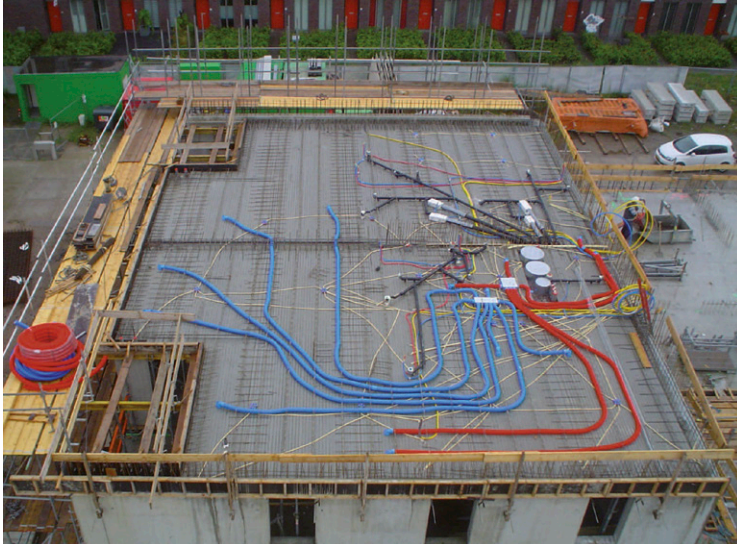

Layout suggestion, Hybalans+ system

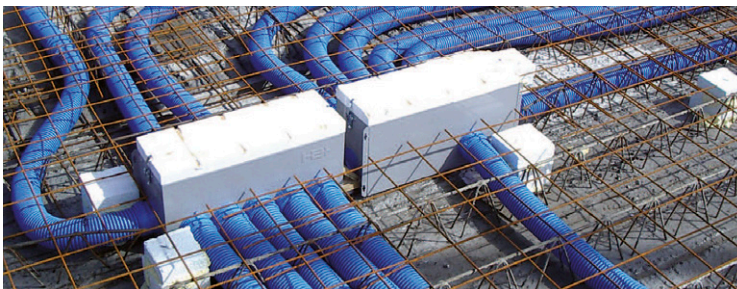

Suggested layout showing air distribution manifold for air supply

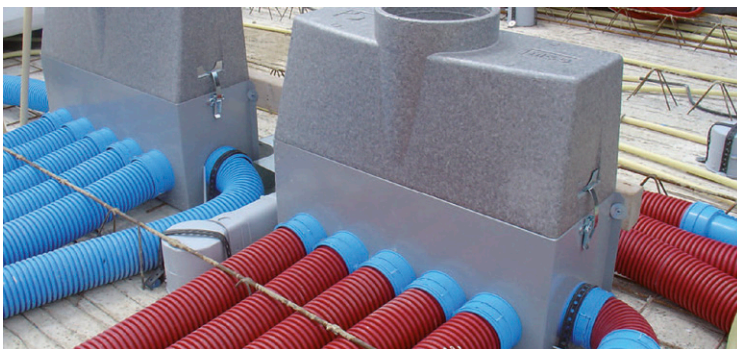

Suggested layout showing air distribution manifold for balanced ventilation



Suggested layout showing right-angle/straight air distribution manifold with 400 x 400 mm extractor plenum 00



AIR DISTRIBUTION SYSTEM

Layout suggestions



Mounted on the floor



Mounted under the floor

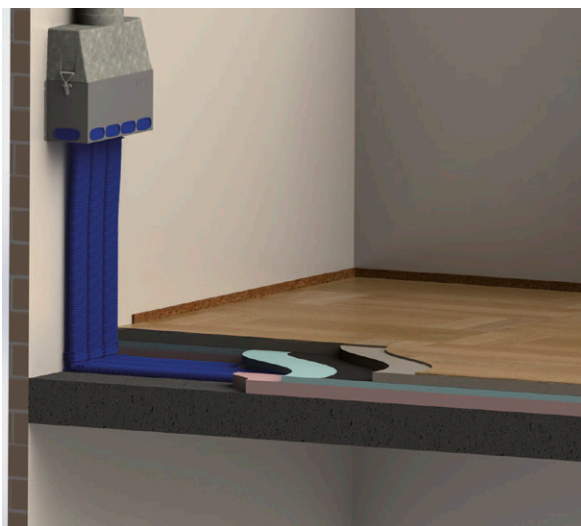

Mounted as wall-hanging unit



INNOVATIVE
PARTNER

2019-02-CB-001

Innovative partner in flue gas & ventilation solutions

mg-flues.com

