

Q RANGE



BRITAIN'S LEADING
TRAILER MANUFACTURER

In Safe Hands

SPECIALISTS IN TRAILER DESIGN & ENGINEERING

For over 50 years, people have put their trust in our trailers, just ask an owner – they are not difficult to find. As specialists in trailer design and engineering, we have continued to set the standard both in the UK and throughout much of Europe.

We are an independent company with one focus: to build the best products on the market. More than 30,000 people choose our trailers each year – but we are not standing still. Our dedicated investment in new technologies and materials ensures that our products continue to exceed the expectations of our customers. We know that quality, strength, value and ease of maintenance are of vital importance to you. That is why we have made them the driving force behind everything we do.



Q7b Road with roof and rack, hinged mesh sides, lightguards and propstands

The new Q Range from Ifor Williams Trailers

The Q Range trailer is a fantastic addition to the huge range of trailers Ifor Williams Trailers already have on offer. This small and robust trailer has all the elements of a classic Ifor Williams Trailer with its galvanised steel, aluminium treadplate floor, treated timber underneath and leaf spring suspension. The Q range trailer will outperform its competitors due to its strong and sturdy build.

There are many small lightweight trailers on the market today but very few can boast the leaf spring suspension and therefore the durability provided by this trailer range. The multipurpose range can be towed behind ATV's or cars (dependent on model chosen*).

Versatility

The Q range is the result of listening to customers and what they would like in a trailer. This new trailer is not earmarked for one industry but seen as versatile to suit landscape gardening, builders, domestic users and agriculture. It can be used for commercial or domestic use in the same day; it is easily cleaned, towed and parked. A trailer you never know you needed but no longer want to be without.

Why choose a Q Trailer?

- Smallest Q trailer has huge payload in comparison to smallest P trailer.
- Treadplate floor is standard in a Q – more hygienic for farmer's stock.
- Treated timber underneath floor for added strength.
- Leaf spring suspension unique to trailers of this size.
- Q trailer has higher sides than a P trailer.
- Formed side panels add extra strength.
- Q range is hot dip galvanised compared to the pre-galvanised P trailer.
- Q range road have unique robust aluminium mudguards.
- Option of a swivel hitch on off-road Q trailer – helpful on difficult terrain.
- Q trailer has different options such as roof and rack as well as hinged solid or mesh sides.

*Please check towing vehicle manufacturer's handbook for maximum unbraked towing limit.



Q5e Road with hinged mesh sides



Q5e off-road with internal partition

The option of an internal partition easily positioned at different points allows lambs on one side and ewes the other – safer transport for all animals.



Q5e off-road with internal partition and stock ramp door



Q5e road with hinged mesh sides

Q5e Off-Road/Road

The Q5 is a compact and robust trailer designed for both road use behind a family car or off-road use behind either a quad or ATV. The trailer is available with either mesh or solid hinged sides as well as stock ramp and propstands.

The off-road trailer comes without lights or mudguards—meaning it is specifically for off-road use and makes the trailer less expensive and lighter than its road alternative.

There are two options for tyres on the off-road Q5e trailer – either the flotation tyres (20.5 × 8-10) or the knobby tyres (22 × 11-8). The latter have a very deep tread depth which helps the trailer stay on track behind the towing vehicle in muddy conditions or hilly terrain. The modest payload of the Q5 off road (150kg) is plenty for transporting a number of ewes and lambs or feed across land more easily reached by off-road vehicles. The option of a 360 degree swivel hitch for the difficult off-road terrain allows the trailer and ATV or vehicle to safely tackle rough ground when travelling to stock for example.

The road Q5e has a payload of 500kg which is plenty for carrying logs for your wood burning stove or picking up supplies from the garden centre. Strong and robust enough for any loads you use it for yet easily manoeuvrable by hand when needed and stored easily in a garage or shed out the way.

Knobby tyres vs Flotation tyres

- The knobby option has a greater tread depth but a lighter maximum GVW.
- The knobby tyre is best for use in muddy conditions and hilly terrain.
- The knobby option is not road legal – purely for off-road use.
- Flotation tyres are the compromise between off-road and legal road use.
- Flotation tyres have a higher maximum GVW.

Q5 Q5e off-road and road versions showing different ramp, hinged sides and internal partition options





G835 off-road with hinged solid sides



Q6 & 7 Off-Road

The Q6/ and Q7 unbraked off-road trailers come with 20.5 x 8-10 flotation tyres and are not fitted with mudguards or lights. This means they are solely for off-road or off-highway use and come with a range of additional accessories and options.

The floor is durable pressure treated timber planking covered with aluminium treadplate and both trailers come with formed side panels for extra strength and are hot dip galvanised for the renowned Ifor Williams durability. They have a gross maximum weight of 750kg and feature the exclusive Ifor Williams beam axle and leaf spring suspension system which has been developed and refined for a safe and stable ride. This gives superior durability and reliability over the normal rubber torsion suspension systems found on similar trailers of this size.

The option of a 360 degree swivel hitch for the difficult off-road terrain allows the trailer and ATV or vehicle to safely tackle rough ground when travelling to stock for example. Both the Q6 and Q7 have the options of either hinged mesh sides or hinged solid sides as well as a roof and rack, stock ramp with stock door or simply a ramp. The roof and rack* is ideal for carrying feed or fencing posts when animals or other items are inside - it really shows the effectiveness of this option - one trip is required instead of two! An internal partition/cross division is also available which has a door to allow sheep through to the front section before loading the second or rear section group.

The applications of this trailer are not just limited to agricultural, almost any task or job where materials are to be hauled by an ATV can be accommodated by the Q range of trailers. From farmers to foresters, smallholders to construction workers there will always be a task for a trailer as versatile as the Q range.

*The roof and rack has a maximum recommended weight of 50kg and uses two fasteners which are easily removed.



Q7b road with roof and rack, hinged mesh sides, metal mudguards, light guards and propstands

Q7

Q7b road with roof and rack and hinged solid sides



Q7

Q7b/e road showing a variety of options



Q6, 7 & 8 Road

All three of these trailers are available as either braked or unbraked versions with mudguards and lights ensuring its legality on the road. All braked versions have a gross maximum weight of 1000kg which is ideal for those heavier loads, whilst the unbraked trailers have a slightly reduced maximum gross weight of 750kg.

These trailers have the durable pressure treated timber, renowned Ifor Williams leaf spring suspension and one piece treadplate floor as well as hot dip galvanised finish. All this ensures the trailer's hardness and reliability for the many tasks it will be used for over the many years it will be in service.

The Q7 has been admired by builders for its versatility. The short ramp length on all the Q range means that a pallet could be loaded straight on to the trailer with ease. The roof and rack option is helpful for keeping plants or other loads dry as well as being able to carry fencing posts or a whole range of other materials*. The numerous tie-down points on the roof and rack allow any load to be secured at any point along.

The majority of quad bikes will fit inside the Q7 with golf buggies fitting in the Q8.

* The roof and rack has a maximum recommended weight of 50kg and uses two fasteners which are easily removed.



Q7e road with roof and rack, hinged mesh sides, stock ramp door, internal partition and propstands

Dimensions

Dimensions in Metres	A	W	L	D	E	F
Q5e Road	0.38	1.02	1.51	1.52	2.6	1.27
Q5e Off-Road	0.38	1.02	1.51	1.52*	2.6	1.27
Q6e Road	0.38	1.22	1.95	1.71	3.02	1.28
Q6e Off-Road	0.38	1.22	1.95	1.71	3.02	1.28
Q6b	0.36	1.22	1.95	1.71	3.02	1.28
Q7e	0.38	1.22	2.19	1.71	3.27	1.28
Q7b	0.36	1.22	2.19	1.71	3.27	1.28
Q8b	0.36	1.45	2.51	1.95	3.62	1.28

*Add 100mm for knobby tyre

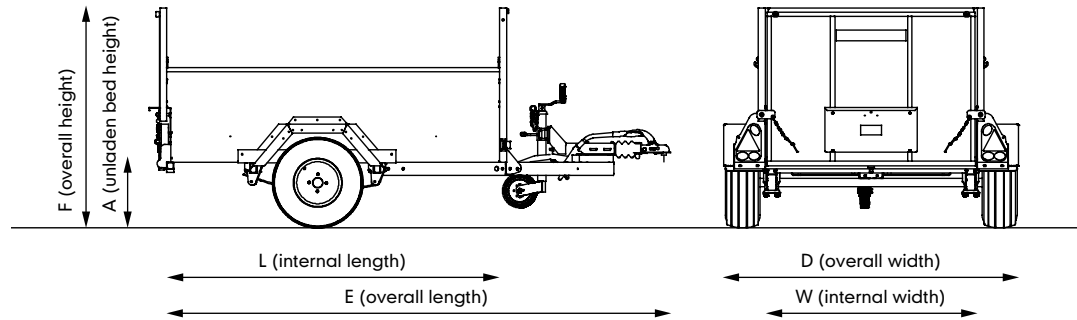

Optional lightguards



Leaf spring suspension is standard



Q5e off-road knobby tyres (22 x 11-8)



Q5/6/7e off-road flotation tyres (20.5 x 8-10)



Optional ramp gates available on Q6, 7 and 8

Options

	Chassis	Unladen Weight	Maximum Gross Weight	Tyres	Suspension	Lights	Mudguards	Stock Ramp	Hinged Mesh Sides	Hinged Solid Sides	Internal Partition	Rear Prop Stands (Pair)	Jockey Wheel	Roof and Rack	Ramp Gates	Light Guards
Q5e Off-Road	Unbraked	185kg	350 kg @ 40kph	22 x 11-8*	Single leaf spring	No	No	Option	Option	Option	Option	Option	Option	-	-	-
Q5e Off-Road	Unbraked	185kg	750 kg	20.5 x 8-10	Single leaf spring	No	No	Option	Option	Option	Option	Option	Option	-	-	-
Q5e Road	Unbraked	200kg	750 kg	20.5 x 8-10	Single leaf spring	Yes	Yes	Option	Option	Option	Option	Option	Option	-	-	Option
Q6b Road	Braked	300kg	1000 kg	195/55R10	Single leaf spring	Yes	Yes	Option	Option	Option	Option	Option	Std	Option	Option	Option
Q6e Off-Road	Unbraked	235kg	750 kg	20.5 x 8-10	Single leaf spring	No	No	Option	Option	Option	Option	Option	Option	Option	Option	-
Q6e Road	Unbraked	250kg	750 kg	20.5 x 8-10	Single leaf spring	Yes	Yes	Option	Option	Option	Option	Option	Option	Option	Option	Option
Q7b Road	Braked	315kg	1000 kg	195/55R10	Single leaf spring	Yes	Yes	Option	Option	Option	Option	Option	Std	Option	Option	Option
Q7e Off-Road	Unbraked	250kg	750 kg	20.5 x 8-10	Single leaf spring	No	No	Option	Option	Option	Option	Option	Option	Option	Option	-
Q7e Road	Unbraked	265kg	750 kg	20.5 x 8-10	Single leaf spring	Yes	Yes	Option	Option	Option	Option	Option	Option	Option	Option	Option
Q8b Road	Braked	390kg	1000 kg	195/55R10	Single leaf spring	Yes	Yes	-	Option	Option	Option	Option	Std	Option	Option	Option

*All off-road trailers are not road legal



Q5e off-road with hinged mesh sides, internal partition and stock ramp door



Q5e road with hinged mesh sides and propstands



Ifor Williams Trailers Ltd
Cynwyd, Corwen,
Denbighshire LL21 0LB UK
Telephone +44 (0)1490 412527
sales@iwt.co.uk

For further information visit our
comprehensive website
www.iwt.co.uk

Product design, descriptions, colours, specifications etc. correct at time of going to press. We constantly strive to improve our products, and from time to time this may result in changes to our range or to individual models. Please check that design, description, colours, specifications described in this brochure are still valid at the time of placing an order.

Our distributors have extensive product knowledge and will be pleased to offer assistance in the selection of your trailer.

© Ifor Williams Trailers Ltd 2014.

All rights reserved.

No part of this publication may be reproduced in any form or by any means, without the prior written permission of Ifor Williams Trailers Ltd.

We would like to thank the following organisations who assisted in the production of this brochure: Coleg Cambria – Llysfasi, Planhigion Glyndwr Nursery (Corwen), Richard Williams Builder's Merchants (Ruthin), Corwen Forestry Timber Products Ltd (Llandrillo) and Mr Hughes, Pentrecelyn, (Ruthin).