



Far-infrared imaging of ThermaHeat® 60

Combining excellent thermal performance to insulation the internal face of an external wall, with a super-efficient radiant heating system, The ThermaHeat® 60 is an ideal solution for both new build and retrofit projects.

Using far-infrared graphite technology ThermaHeat® 60 is a complete low energy radiant heating solution delivering a maximum heat output of 300W/m<sup>2</sup>. Running on just 36V transformers the ThermaHeat® 60 system is extremely cost and energy efficient



### Advantages:

- Sustainable raw materials and constituents, sustainable manufacture, sustainable use.
- Dry build: building work causes minimum amount of inconvenience, can be finished directly.
- Overall system with integrated foils, so no mistakes or failure costs.
- Constantly high thermal yield (vapour-resistant construction without cold bridges).
- Can be used for a height of up to 3600mm, without leaning or warping.
- ISSO certified.

**Product Warranty:** 15 years manufacturer warranty on the heating element

### Technical Details



**Lengths (mm)**  
2600, 3000



**Width (mm)**  
600



**Thickness (mm)**  
Panel – 60mm  
Overall – 80mm



**Weight**  
9.1 kg/m<sup>2</sup>



**Fire Resistance**  
<20 min (NEN 6069)



**Insulation**  
0.35 W/m<sup>2</sup>K  
(inclusive 20mm air cavity and one brick wall)



**Sound Insulation**  
Improvement 5dB

# ThermaHeat 60

Installation Profiles

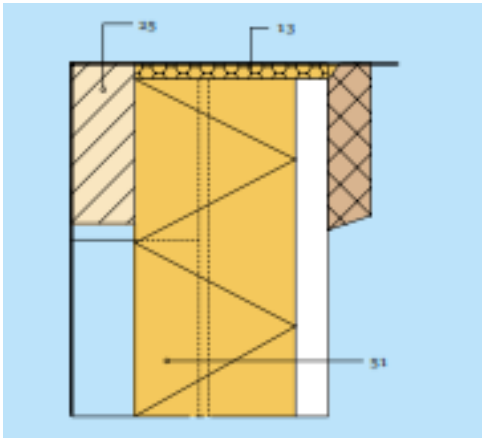

Ceiling Connection

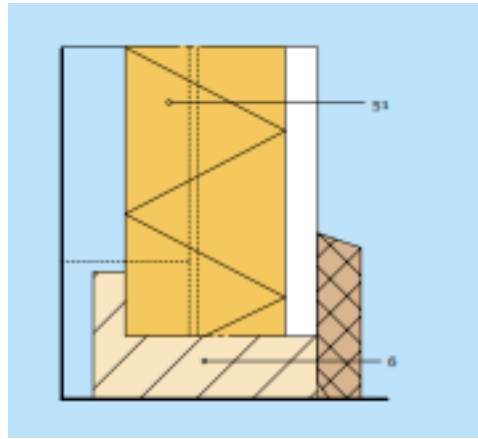

Floor Connection

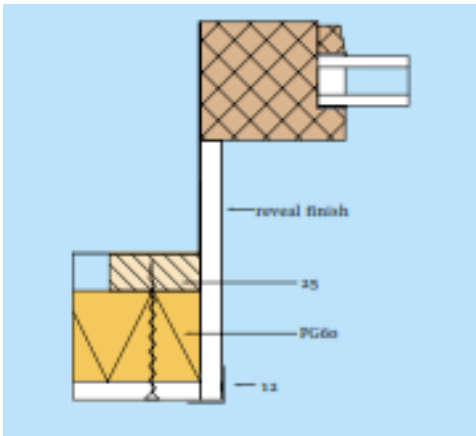

Casing Connection

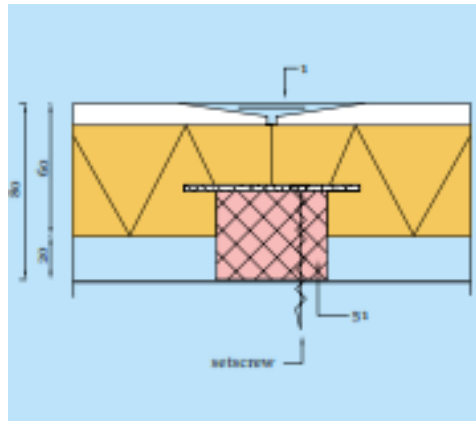

Joint

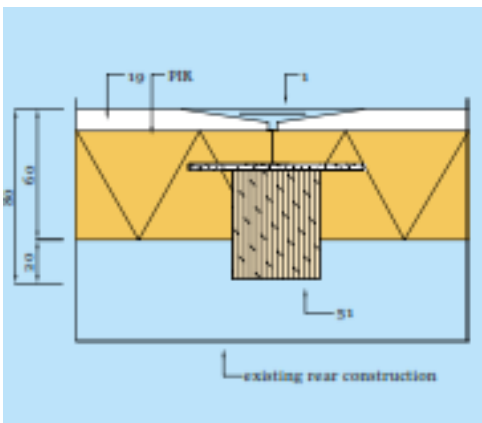

Free Standing Joint

**Datum Phase Change Ltd**

Curles Manor, Pelham Road, Clavering, Essex. CB11 4PW

Tel: 01799 550222 | Email: [enquiries@therma.cool](mailto:enquiries@therma.cool)