



# **THE SYNERGY ELLESSE CF**

**INSET CONVECTION HEATER SUITABLE FOR NATURAL GAS  
& PROPANE**

**USE, INSTALLATION & SERVICING INSTRUCTIONS**

**! IMPORTANT NOTE !  
THIS FIRE IS HEAVY AND ASSISTANCE SHOULD BE  
SOUGHT WHEN LIFTING**

**ALL INSTRUCTIONS MUST BE LEFT WITH THE USER FOR  
SAFE KEEPING**

**MANUFACTURED by:**  
**Nu-Flame Limited**  
Unit 4, Kimpton Trade & Business Centre  
Minden Road, Sutton, Surrey SM3 9PF  
Tel: 020 8254 6802  
Fax: 020 8641 9992  
Email: [sales@nu-flame.co.uk](mailto:sales@nu-flame.co.uk)

Country of Destination – GB & IE



## CONTENTS

Section No	Subject	Page
<b>User Section</b>		
-	Contents Page	3
1	Pack Contents & Unpacking	3
2	Important Notes	3
3	Lighting & Controlling the Fire	5
4	Cleaning the Fire	8
5	Servicing	8
<b>Installation Section</b>		
6	Installation Requirements	9
7	Appliance Data	9
8	Appliance & Trim Dimensions	11
9	Flue Requirements	11
10	Ventilation	11
11	Gas Supply	
<b>SECTIONS 12 to 14 Are For Various Installation Options For WALL MOUNTED TELEVISION Also Refer To Section 16</b>		
12	Hole in the Wall Installations for Steel & Glass Trim Styles With Appropriate Sealing Frame	12
13	Hole in the Wall Installations for Echo Trim Style	14
14	Hole in the Wall Installations with Marble, Slate or Stone Slips All Trim Styles	16
15	Fire Surround Installations All Trim Styles	18
16	Installation Requirements for Wall Mounted Televisions Additional Requirements for All Trim Styles	20
17	Arrangement of the Fuel Effect.	23
18	Testing, Commissioning & Use	25
19	Briefing the Customer	28
20	Servicing	28
21	Fault Finding Guide, Symptoms & Possible Cause	29
22	Energy Class & Product Fiche & EU Declaration of Conformity	31
23	Diagram of Infrared Control System	34
	Guarantee	35

## 1. PACK CONTENTS:

The Fire Will be Supplied on a Small Pallet with Additional Boxes.

The Very Large Box contains: Main Casing (with Riser Plate if ordered), Sealing Frame (if ordered) and Main Door (all assembled together), Fuel Tray and Radio Frequency Handset (as ordered either Thermotronic or Thermostatic Thermotronic), Cable Fixing System and Screwdriver (for unscrewing the Inner Glass Door).

### 1.1 - Unpacking

a). To make the fire more manageable and prevent the possibility of damage it makes sense to remove various Trim parts, Doors (Glass Doors specifically) and the Burner Assembly prior to Installation as detailed below.

**Note: If the Fire is to be Installed in a Fire Surround a Riser Plate Must have also been ordered and will already be fitted to the base of the fire.**

**This is very important because without the riser plate the Outer Door will foul on the Hearth.**

b). Additional boxes contain: Log Set (Dark Wood or Silver Birch), Sand Coloured Bark Chippings, Black Coloured Bark Chippings, Large Bag of Natural Coloured Vermiculite Granules and Small Bag of Black Coloured Vermiculite Granules & a Pack of Embaglow.

c). If a Wall Mounted Fire with Wall Mounted Television has been advised then a TV Glass Heat Shield will have been supplied and in addition if the Synergy Glass has been ordered the Glass Shelf will also have been supplied with the Sealing Frame.

**Important:** For Wall Mounted Fire Installations with Slips the appropriate Glass Shelf must also have been ordered.

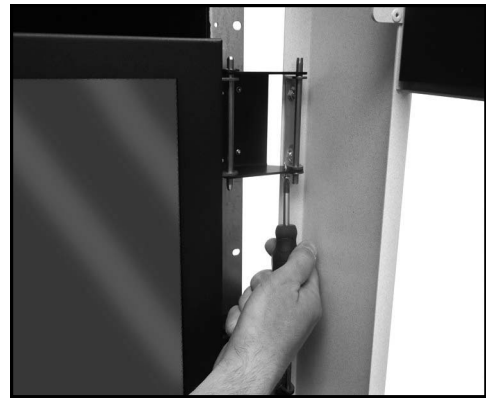

**Important: Store the Trims and Doors in a safe secure area as all parts will have been Quality Control checked prior to dispatch and Nu-Flame will not accept Claims for damage that occurs on site.**

**The Glass Doors (if ordered) should be stored such that the glass is not prone to being chipped or scratching.**

### 1.2 - Removal of Components

#### a). Fires Ordered with Steel or Glass Trims

- i) The Outer Door will have to be removed and stored carefully to allow access for removal of the other components.
- ii) Open the outer door by pulling at the left side to release it from the magnetic catches and open the outer door.
- iii) Now at the hinge end push out the two Hinge Pins to release the Outer Door.
- iv) The Sealing Frame (if ordered) can now be removed by removing the 6 fixing screws.
- v) Now use the Screwdriver provided remove the 2 screws securing the Inner Glass Door, push out the Hinge Pins.
- vi) Remove the 4 screws securing the burner mounting plate assembly; then lifting at the rear, swing the whole assembly out and clear of the fire. Take care not to mark the liners in the fire.

**Note: These small parts must be placed in a safe area as they will be required later.**

#### b). Fires Ordered with Echo Trim & Echo Trim & Glass Door

**Note:** For the Echo Trims (Steel & Glass Doors) the upper Hinge Pin is fitted upward and is held in place with a small bracket which will need to be removed first before the Hinge Pin can be removed.

- i) The Outer Door will have to be removed and stored carefully to allow access for removal of the other components.
- ii) Open the outer door by pulling at the left side to release it from the magnetic catches and open the outer door.
- iii) At the hinge end remove the screw securing the top Hinge Pin then slide out both Hinge Pins to release the Outer Door.
- iv) The Echo Trim can now be removed by removing the 4 fixing screws.
- v) Now use the Screwdriver provided remove the 2 screws securing the Inner Glass Door, push out the Hinge Pins.
- vi) Remove the 4 screws securing the burner mounting plate assembly; then lifting at the rear, swing the whole assembly out and clear of the fire. Take care not to mark the liners in the fire.

**Note: These small parts must be placed in a safe area as they will be required later.**

# THE SYNERGY ELLESSE CF USER INSTRUCTIONS

## 2. IMPORTANT NOTES

- a. This appliance must be installed by a properly qualified (in accordance with National & Local Regulations) Installation Engineer.
- b. The connection of this appliance and ventilation requirements (if any) are to be according to National & Local Codes.
- c. This appliance does not normally require any purpose provided additional ventilation, however if it has been found necessary to add a vent periodically check that it is free from obstruction.
- d. Consult all Instructions before Installation and Use.
- e. Do not throw rubbish on, or attempt to burn any materials on this appliance. Any Debris or Foreign Matter must be removed from the fire.
- f. Under No Circumstances must this fire be used if the Glass Panel is broken damaged or cracked or if the Door Seal is damaged.
- g. The inner glass door, outer trim and outer glass door (if applicable) of this fire will become very hot during use, cloths or combustible items must not be placed close to or on the fire.

**Very Important: We recommend that a Fireguard conforming to BS8423 should be used for protection of Young Children the Elderly, Infirm and Pets.**

- h. The appliance should be Serviced Annually in accordance with the Gas Safety & Uses Regulations.
- i. Where the flue has been used for Solid Fuel it must be swept before Installation.
- j. If at any time you smell gas or fumes turn the fire off and contact your Installer.
- k. These Instructions must be left with the User for future reference.
- l. During its first period of use any protective coatings and oils will burn out of the appliance and it is wise to ventilate the room for the first few hours of use.
- m. This appliance is fitted with an oxygen depletion sensing system, which automatically shuts off the gas supply to the fire if the oxygen level in the room is depleted, due to lack of primary air, or obstructed flue (blocked chimney) that would lead to incomplete combustion of the gas. It must not be tampered with and only replaced with a genuine Nu-Flame ODS.
- n. In the event that the fire shuts down due to any reason, attempt to restart it. If there is a continuing problem, call in a properly qualified specialist engineer.
- o. There are no user replaceable parts in the appliance apart from the batteries.
- p. The chimney should be regularly checked to ensure that all the products of combustion are entering the flue & that there is no build up of soot. If there is, the appliance must be serviced.
- q. Simulated logs and simulated bark chips, manufactured from refractory fibre, are supplied with this appliance. Do not use real logs or real bark chips as this is dangerous. If the simulated logs or simulated bark chips need renewing please obtain suitable replacements from a Nu-Flame Stockist.
- r. The fire must be installed in accordance with the rules in force and these Instructions it must be installed into a builders opening as detailed in these Instructions.
- s. No combustible materials e.g. curtains must be closer than 500mm to the fire.
- t. For Fire Surround Applications a 150mm (6") combustible shelf can be fitted above the fire provided it is 350mm above the Fireplace Opening.
- u. The Fire can be installed into a suitably designed fire surround with a 150°C Rating.
- v. Take care with some Micro Marble Materials claiming a 150°C Rating as they may give off odours, blister or discolour.
- w. Ensure the Door Release Screwdriver is left with the customer and if possible show them how to open the door for cleaning and how to secure the door after cleaning. When a Glass Outer Door is provided show the Customer how to Open The Door by pulling open at the lower left side. Stress that this should only be done when the fire is cool.
- x. Explain to the customer that over time some wall staining will occur and this is due primarily to particles of dust present in the hot convection air circulating up and over the fire and sticking to the wall.
- y. If a Wall Mounted Television is mounted above the fire you must take account of the Television Manufacturers Instructions. The Installation requirements provided with these Instructions must be adhered to for such installations and are provided to ensure an acceptable ambient temperature is provided above the fire.
- y. In adverse weather conditions where high winds are experienced it is possible that products of combustion/smoke could be blown down into the room, a condition known as Down Draught. You **Must** contact your Installer immediately if this is experienced and turn the fire off and do not use it until the problem is corrected.

**! WARNINGS & IMPORTANT NOTES ! THE THERMOSTATIC THERMOTRONIC CONTROL SYSTEM PROVIDES THE MEANS FOR UNATTENDED OPERATION OF THE FIRE IF THE PROGRAMS OR THERMOSTATE SETTINGS ARE USED - THIS COULD POSE A DANGER IF COMBUSTIBLE MATERIALS ARE TOO CLOSE TO THE FIRE OR IF YOUNG CHILDREN, THE ELDERLY, INFIRM OR PETS ARE LEFT UNATTENDED. THE INNER GLASS DOOR AND/OR OUTER GLASS DOOR ON THESE FIRES WILL BECOME VERY HOT DURING USE THEREFORE IT IS VITAL THAT GUARDING IS PROVIDED - SEE ITEM G. ABOVE. THE SYNERGY RANGE HAS A UNIQUE BURNER SYSTEM WHERE THE FLAME SIZES AND COLOURS WILL CHANGE & THE FIRE WILL ALSO MAKE POPPING & BURBLING NOISES LIKE A REAL FIRE**

### Health & Safety Advice Refractory Ceramic Fibre (RCF)

**Advice when working with Fuel Bed Components including Installing, Servicing and Disposal.**

The Fuel Effect parts and possible Linings of this fire are made from Refractory Ceramic Fibre (R.C.F.) a Class 2 Carcinogen which is a material designed for this Application. Excessive exposure to these types of materials may cause temporary irritation to eyes, skin and respiratory tract. Therefore take care when handling these articles to ensure dust is kept to a minimum. It is not necessary to wear protective clothing when handling these articles but we do recommend you follow the normal hygiene rules of not smoking, eating or drinking in the work area, and always wash your hands before eating or drinking. To minimise the release of RCF fibres during installation and servicing a HEPA filtered vacuum is recommended to remove any dust accumulated in and around the fire both before and after working on it. When Servicing and if replacing these parts we do not recommend they are broken up but are sealed within a heavy duty polythene Bag and labelled as "RCF waste". This is not classified as "hazardous waste" and may be disposed of at a local licensed landfill site.

### 3. LIGHTING & CONTROLLING THE FIRE

#### 3.1 General

The fire is available with 2 Control Options:

Option a) The Nu-Flame Thermatronic (Fully Sequential) Radio Frequency Electronic Control System.

The fire is fully operated using the Handset.

Option b) The Nu-Flame Thermostatic Thermatronic (Fully Sequential) Radio Frequency Electronic Control System.

The fire is fully operated using the Handset but also the Handset allows you to do control the temperature of the room during the day or night, and timer programs.

Both Control Systems are battery operated that use a microprocessor to provide the working sequences needed by the fire, and when used with an oxy-pilot have all the safety features required by law and CE approval.

Commands are accepted by the microprocessor when buttons are pressed. An audible beep means that the command is received, and the push buttons should then be released.

#### 3.2 Using the Thermatronic RF System

Control can only be achieved if the Handset is pointed at the Fire.

The red light will flash each time you press the Handset.

**a. Ignition.** Simultaneously press and hold the red/off and the large flame button (linked by arrow) until a short acoustic signal confirms that the sequence has begun, then release the buttons.

Continuous audible signals confirm that ignition is in progress.

When pilot ignition is confirmed the motor will open the valve to maximum flame height – this takes about 30 seconds. The main burner will then light at the high flame setting.

**b. Flame Height Adjustment.** Press the small flame button until the flame height is at the desired position. If you try to go beyond the preset low flame setting the fire will turn off leaving the pilot burner alight (This is the standby position).

You will learn from experience how to achieve the minimum preset low flame setting.

**c. Relighting the Fire.** To relight the fire from the standby position, or to increase the flame setting from low flame, simultaneously press the red/off button and large flame buttons (linked by arrow).

Please note that you can have the flame height anywhere between maximum and preset low.

For fine adjustment simply tap the large and small flame buttons.

**d. Switching Off.** Press the red/off button.



#### 3.3 Using the Thermostatic Thermatronic RF System

Control can only be achieved if the Handset is pointed at the Fire.

You will see that the Handset as a screen with symbols and reference should be made to the following screen settings for each stage of operation.

With the fire in the off position the screen will look as shown below.

This is the Manual Setting display and will be used to first light the fire.

The screen shows the following:

Note: Radio Frequency Symbol Shows Only When Pressing Handset

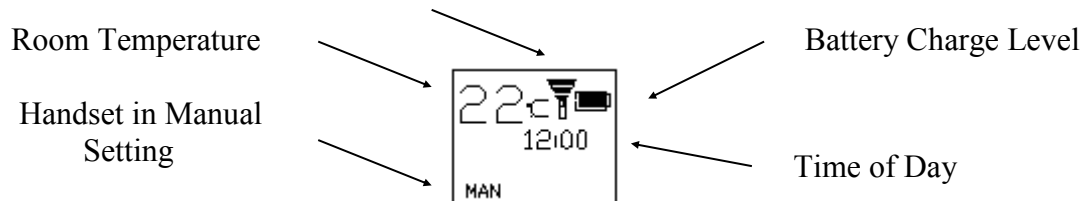

**a. Ignition.** Simultaneously press the Off and Large Flame Buttons (linked by the line/star symbols) until a short acoustic signal confirms that the sequence has begun, then release the buttons.

Continuous audible signals confirm that ignition is in progress.

When pilot ignition is confirmed the motor will open the valve to maximum flame height – this takes about 30 seconds. The main burner will then light at the high flame setting.

**b. Flame Height Adjustment.** Press the small flame button until the flame height is at the desired position. For fine adjustment tap the Large Flame or Small Flame buttons

If you try to go beyond the low flame setting the fire will turn off the main burner leaving the pilot burner alight (This is the standby position).

You will learn from experience how to achieve the minimum low flame setting.

**c. Relighting the Fire.** To relight the fire from the standby position, or to increase the flame setting from low flame, simply press the large flame button.

Please note that you can have the flame height anywhere between maximum and low.

For fine adjustment simply tap the large and small flame buttons.

Note: You can also automatically set the fire at either Tall or Low Flame setting by pressing the desired flame Button twice.

**d. Switching Off.** Press the off button



You can now proceed to the other features of the Handset such as Setting the Time, Temperature and Time Programmes.

**e. Setting Temperature - Time in Centigrade-24Hour Clock or Fahrenheit-12Hour Clock.**

- Simultaneously Press the Off and the Down Arrow buttons until the display changes from Fahrenheit -12Hour Clock to Celsius -24Hour Clock and visa versa.

**f. Setting the Time.**

The time of day will flash after either:

- Installing the batteries or
- Simultaneously pressing the Up Arrow and Down Arrow buttons.
- Press the Up Arrow button to set the Hour.
- Press the Down Arrow button to set the Minute.
- Press Off or simply wait to return to the manual screen.



**IMPORTANT : For the following modes of controlling the fire automatically for Temperature or Timer Programs the Fire Must be left in the Standby Setting (Pilot Lit) and left on the chosen Setting, with the Screen showing either Temp or Timer.**

**g. Setting the Day Time Temperature.**

- Briefly Press the Set Button to scroll to TEMP (Sun \* Symbol - Daytime) Mode.
- Hold the Set Button until the TEMP flashes then release.
- Now press the Up Arrow button to increase the Daytime - Sun temperature. or
- Press the Down Arrow button to decrease the Sun-Daytime temperature.
- You can now press the Set Button to scroll to setting the Night Time Temperature or press off to return to Manual Screen.



**h. Setting the Night Time Temperature.**

- Briefly Press the Set Button to scroll to TEMP (Moon Symbol ) Night Daytime) Mode.
- Hold the Set Button until the TEMP flashes then release.
- Now press the Up Arrow button to increase the Night ) Time - Moon temperature. or
- Press the Down Arrow button to decrease the Night Time ) Moon temperature.
- You can now either leave the handset on the TEMP setting and with the fire lit the room temperature will be controlled or return to the Manual Screen. Your Settings will remained stored.



**Note:** With the Temperature Settings now set the Handset will have to be left in the TEMP mode to control the fires temperature.

**Note:** In the Manual Mode neither of the Automatic TEMP or TIMER settings will be active.

**Note:** If you Set the Room Temperature below the present room temperature the fire will go straight to the Standby Setting until the temperature drops below the Set Temperature at which point the main burner will relight.

**Note:** The Room Temperature is sensed by the Handset so place it in the ideal position to control the room temperature.

**Note:** An Holder is available for the Handset as an optional extra and this should be positioned to control room temperature.

**Note:** If at any time you wish to correct or check the settings you have made you can simply keep pressing the Set Button until the screen displays the Manual Setting and repeat the operations as detailed above.

**i. Setting the Timer Programs P1 and P2 for Daytime & Night Time Settings.**

- The Timer Programs are identified by the symbols P1 and P2 on the screen and each can be set for both daytime (sun symbol) and night time (moon symbol) settings.

**Note :** Both Programs have to be set, you cannot just set one program, however you can set both at the same settings.

**Setting the P1 (Program 1), On Time**

- Briefly Press the Set Button to scroll to TIMER Mode.
- Hold the Set Button until P1 Sun Symbol (Daytime) is displayed and the time flashes.
- Press the Up Arrow button to set the Hour.
- Press the Down Arrow button to set the Minute.



**Setting the P1 (Program 2), Off Time**

- Briefly press the Set Button to scroll to the P1 Moon Symbol (Night time) is displayed and the time flashes.
- Press the Up Arrow button to set the Hour.
- Press the Down Arrow button to set the Minute.



**Setting the P2 (Program2), On Time**

- The Screen will automatically proceed to setting the P2 Settings
- Briefly Press the Set Button to scroll to the P2 Sun Symbol (Daytime) is displayed and the time flashes.
- Press the Up Arrow button to set the Hour.
- Press the Down Arrow button to set the Minute.



**Setting the P2 (Program2), Off Time**

- Briefly press the Set Button to scroll to the P2 Moon Symbol (Night time) is displayed and the time flashes.
- Press the Up Arrow button to set the Hour.
- Press the Down Arrow button to set the Minute.



- **Both Programs** Press Off or simply wait to return to the Manual Screen.

**Note :** With the Programs now set the Handset will have to be left in the TIMER mode to enable the programs to control the fire.

### **3.4 - BATTERY REPLACEMENT**

**Applies to both Control Systems - (Must only be done when the fire is Cool)**

- a. A feature of the Thermostatic Thermatronic Handset is it as a Battery Charge Indicator shown in the screen on the Handset which will determine when both the Handset and Receiver Batteries need changing, however also see 'b'.
- b. For Both Control systems, Battery replacement is recommended at the beginning of each heating season, or when an acoustic error message sounds during ignition.
- c. Error Message – Long signals (0.8 second tone – 0.2 second break) during ignition – probable cause - batteries in electronic receiver box are nearly discharged.
- d. Error Message – 5 second continuous tone – probable cause – cable disconnected or on/off switch on valve is in off position.
- e. Batteries - Electronic Receiver Box - 4 x AA good quality alkaline - Handset - 1 x PP3 good quality alkaline.
- f. To change the Handset battery slide open the plastic panel on the back of the Handset.
- g. To change the Receiver Batteries open the outer door by pulling pull at the left side to release it from the magnetic catches. Locate the electronic receiver box, underneath the fire on the left hand side. Slide open the plastic cover to gain access to the battery compartment. You can detach the Receiver by pulling it off its Velcro Pad to make access easier but remember to put it back in the same position.

**Note: Only Change The Batteries When The Fire Is Cold**

**! WARNING! THE THERMOSTATIC THERMOTRONIC CONTROL SYSTEM PROVIDES THE MEANS FOR UNATTENDED OPERATION OF THE FIRE IF THE PROGRAMS OR THERMOSTATE SETTINGS ARE USED - THIS COULD POSE A DANGER IF COMBUSTIBLE MATERIALS ARE TOO CLOSE TO THE FIRE OR IF YOUNG CHILDREN, THE ELDERLY OR INFIRM OR PETS ARE LEFT IN ATTENDANCE.**

### **3.5 - RESETTING THE MERTIK MAXITROL LOGIC CIRCUITS - IF THE HANDSET DOES NOT WORK APPLIES TO BOTH CONTROL SYSTEMS**

**Must only be done when the fire is Cool**

**Basic Reset** - It sometimes happens that (such as when the handset buttons are pressed out of sequence) the fire stops working because the logic circuits get confused and need to be reset.

To do this, simply remove the 4 x AA batteries from the Receiver Box (see section 2.4f above), wait for 1 minute and then refit the batteries. Wait for another minute and then point the handset at the fire and press the red/off button. Wait for another minute and then start the fire as normal. If the fire does not start repeat the resetting procedure. If the fire still does not work a Full Reset can be tried.

**Full Reset** - If you obtain a new handset the control system will need to learn the handset's unique code via a Full Reset. Also, if the fire is not working and the Basic Reset has not worked a Full Reset can be carried out:

Open the outer door by pulling at the left side to release it from the magnetic catches and open the outer door, locate the electronic Receiver Box.

Locate the Reset Hole on the side of the Receiver and using a pen press and hold in the Reset button until you hear two beeps.

The first beep is short and the second beep is long. After the second beep release the Reset Button.

Now on the Handset, within the next 20 seconds press and hold the Small Flame Button until you hear two additional short beeps confirming the code is set in the Receiver.

If you hear one long beep the Code as not been set so repeat the procedure.

If after carrying out the above procedure the situation is not corrected it will be necessary to contact your Installer.

**Note: For the Installation/Service Engineer** - Resetting of the Handset & Control System is also covered in Section 21.1 page 29.

#### 4. CLEANING THE FIRE

- a. Allow to cool before cleaning.
- b. The outside of the glass can be cleaned as follows:
  - Clean glass using (preferably distilled) water and a soft lint free cloth ensuring the glass is dried thoroughly afterwards, again using a lint free soft cloth.
  - If stubborn marks persist use a purpose produced Ceramic hob cleaner to clean the area again using a soft lint free cloth.
  - Under no circumstances must an abrasive cleaner be used as this will scratch the glass.
- c. If the fire also as an outer glass door this can be pulled open off its magnetic catches from the left side and can be cleaned as detailed above.
- d. It is quite normal for soot to build-up on the inside of the glass panel over time.
  - The inside of the Glass Door can be cleaned as follows:
  - Open the outer door, by pulling on the centre of the left hand side.
  - Using the Pozidriv screwdriver provided unscrew the 2 screws to the Left Side of the door.
  - Follow instructions in section b. above.
- e. The logs must **not** be cleaned or moved.
- f. The outer surfaces of the fire can be cleaned with a damp lint free cloth, do **not** use abrasive cleaners.

**! IMPORTANT NOTE !** Under no circumstances must the fire be operated without the glass door being fully closed and secured.

#### 5. SERVICING

- a. The fire should be Serviced Annually in accordance with the Gas Safety & Uses Regulations.
- b. This fire contains no User Serviceable Parts apart from the batteries.
- c. Servicing must be carried out by a Registered Installer.
- d. For Servicing or Spare Parts contact your Installer quoting the Fire Name, Model and Serial Number, which can be found on the Data Badge. To find the Data Badge/Plate; with the fire cool open the outer door, the Data Badge/Plate can be found at the base next to the Control.
- e. In the event that the fire shuts down due to any reason, attempt to restart it. If there is a continuing problem, call in a properly qualified specialist engineer.
- f. **Under No Circumstances** must this fire be used if the Glass Panel is broken damaged or cracked or if the Door Seal is damaged.



# INSTALLATION AND SERVICING INSTRUCTIONS

## 6. INSTALLATION REQUIREMENTS

**THIS APPLIANCE MUST BE INSTALLED AND SERVICED BY A PROPERLY QUALIFIED, (IN ACCORDANCE WITH LOCAL & NATIONAL CODES), INSTALLATION ENGINEER.**

It is the Law in the UK that All gas appliances are installed by a competent person in accordance with the GAS SAFETY(INSTALLATION AND USE ) REGULATIONS 1998 (As amended), the relevant British Standards for Installation work, Building Regulations, Codes of Practice and these Instructions . In the UK a Registered Installer is deemed competent. In the Republic of Ireland, all Irish Standards, Local Codes and Bord Gais recommendations should be adhered to.

The Installation should also be carried out in accordance with the following where relevant:

1. BS5871 Part2
2. BS5440 Parts 1& 2
3. BS6461 Parts 1&2
4. BS6891
5. BS8303

Building Regulations and Standards issued as relevant by the Department of the Environment or the Scottish Development Department.

In the Republic of Ireland Installation should be carried out in accordance with IS813, ICP3, IS327, Building Regulations, Codes of Practice, these Manufacturers Instructions and any Rules In Force.

Particular Reference should be made to the Ventilation Requirements, for the UK this Appliance would not normally require any additional purpose provided ventilation, for the Republic of Ireland ventilation should be in accordance with IS813 Domestic Gas Installations.

Failure to comply with the above could leave the Installer Liable to Prosecution and Invalidate the Warranty.

### IMPORTANT

BEFORE PROCEEDING WITH THE INSTALLATION READ THESE INSTRUCTIONS CAREFULLY.  
THESE INSTRUCTIONS SHOULD BE LEFT WITH THE USER FOR SAFE KEEPING AND FUTURE SERVICING.

PRIOR TO INSTALLATION ENSURE THAT THE GAS TYPE AND PRESSURE ARE AS STATED ON THE APPLIANCE DATA PLATE.

### 7 APPLIANCE DATA

- a. Gas Type: See Data Plate, (Natural Gas at 20mbar or Propane at 37mbar).
- b. Burner Pressure: Natural Gas 19.3mbar hot Propane 34.6mbar hot
- c. Control Systems: Thermatronic & Thermotronic Thermostatic Control Systems operated by Handset pointed at Receiver.
- d. Fire Safety: Oxygen Depletion & Flame Failure Device.
- e. Ignition: Full Sequential Control.
- f. Inlet Connection: 8mm Compression Fitting to Gas Isolation Elbow.
- g. Category: I2H, I3P.
- h. Injector: Natural Gas (G20)-400 Multi hole. Propane (G31) - 240 Single hole.
- i. Heat Input: High: Natural Gas (G20) - 6.4kW Gross (5.77kW Net). Propane (G31) - 6.65kW Gross (6.12kW Net).
- j. Heat Input: Low: Natural Gas (G20) - 2.8kW Gross (2.5kW Net). Propane (G31) - 2.8kW Gross (2.6kW Net).
- k. Efficiency Class: 1 The Efficiency of this appliance has been measured as specified in BS7977-1:2009 and the results obtained were 72.1% Gross (80.0% Net) on Natural Gas and 76.8% Gross (79.7% Net) on Propane. The test data has been certified by BSI (0558) and can be used in the UK Government's Standard Assessment Procedure (SAP) for Energy Rating of Dwellings.
- l. Heat Output: High: Natural Gas (G20) - 4.62kW Propane (G31) - 4.88kW
- m. Heat Output: Low: Natural Gas (G20) - 1.9kW Propane (G31) - 1.9kW
- n. Pilot ODS Type: Natural Gas (G20) - P461 0307. Propane (G31) - P477 0906.
- o. Nitrous Oxide (NOx) - 130mg/kWh

### 8 APPLIANCE DIMENSIONS with Optional Door and Frames

**8.1 The Diagram below shows the General Fire Sizes fitted with the Steel Door with Sealing Frame. For other Door and for Frame Style Options see the next page.**

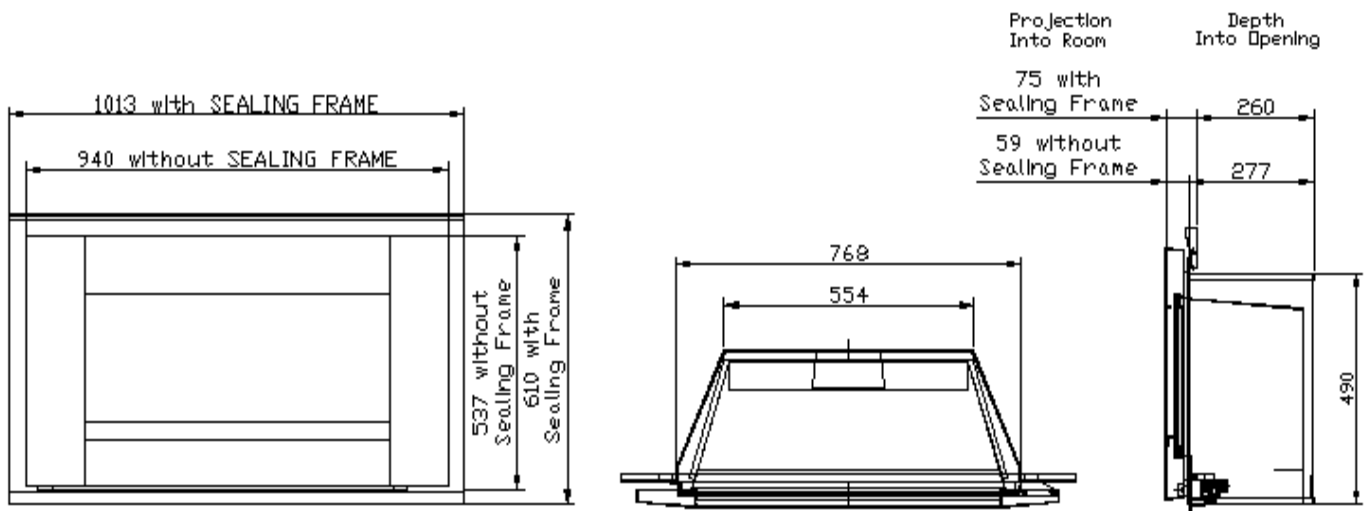

**8.2 The Synergy Ellesse CF is available with various Trim Styles with Glass or Metal Door Options. Some Styles also have a Sealing Frame Option (Normally used for Wall Mounted Installations).**

The general dimensions are shown with a table below showing the minimum flat area required around the Fireplace Opening. The Synergy Ellesse CF Steel & Glass Options can be supplied with or without the Sealing Frame for different applications. The Synergy Ellesse CF Steel can only be Installed below a Wall Mounted Television if Installed in a Suitable Fire Surround. All other Trim Options can be Installed below a Wall Mounted Television be it in a suitable fire surround or wall mounted subject to specific requirements which should be discussed with your Nu-Flame stockist and subject to the requirements in these Instructions.

The Side Views show how far the Trims project from the wall.

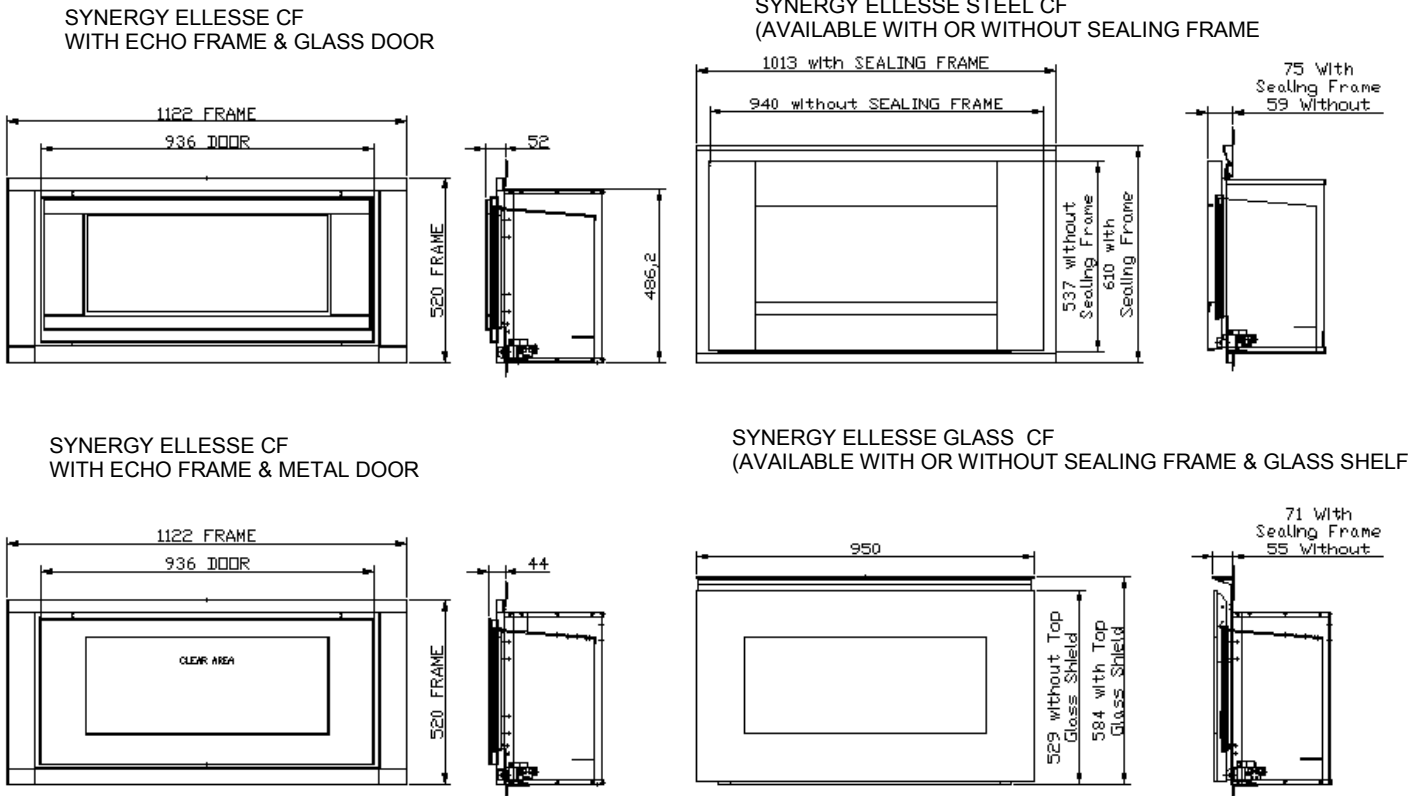

**Minimum Flat Sizes for Doors & Frames (Central Around Opening)**

	Width (mm)	Height (mm)
Synergy Ellesse CF Echo Trim with Metal Door	1140mm	540mm
Synergy Ellesse CF Echo Trim with Glass Door	1140mm	540mm
Synergy Ellesse CF Steel Trim (No Sealing Frame)	1135mm	560mm
Synergy Ellesse CF Steel Trim (With Sealing Frame)	970mm	630mm
Synergy Ellesse CF Glass Trim (No Sealing Frame or Shelf)	980mm	550mm
Synergy Ellesse CF Glass Trim (With Sealing Frame & Shelf)	980mm	605mm

**Note:** Where a the Synergy Ellesse CF Steel or Glass Trims combinations is to be Installed in a Fire Surround a Riser Plate Must have been specified which will raise the fire by 30mm to allow for the Metal or Glass Door to open clear of the Hearth.

**Note:** Where a the Synergy Ellesse CF Glass Trim is to be Wall Mounted the Glass Shelf will be supplied and **Must** always be fitted.

**Note:** This does not take account of any up stand that may be present around the Hearth for which a greater height allowance may be required. More detail is provided in Section 15.

## 9. FLUE REQUIREMENTS

**These checks MUST be made during any site survey or before constructing the Builders Opening**

**Note : Not Suitable for Standard Pre-Cast Flues however some Pre-Cast Flues may meet the Minimum Dimensions as Detailed below**

The Appliance is suitable for Installation into the following types of Flue.

- a. Conventional Stone/Brick Built Flue (Class 1) with a minimum cross sectional dimension of 175mm (7") with a minimum effective height of 3 meters.
- b. A Flue Lined with a 5" Flexible Flue Liner (Minimum Size) connected to a Register Plate fitted and sealed at the top of the Builders Opening with a minimum effective height of 3 meters.
- c. A purpose designed flue box to BS715 fitted with a 5" twin walled flue with a minimum effect height of 3 meters. Details are available from your authorised supplier.
- d. The flue **MUST** be free of any obstructions. Any dampers or restrictors **MUST** be removed. Some dampers are impractical to be removed; therefore they **MUST** be fixed in some way in the **OPEN** position.
- e. The chimney/flue should be swept if it has been used for solid fuel.
- f. Ensure that only one fireplace is served by the flue system.
- g. Ensure that the chimney/flue is continuous from inlet to termination.
- h. Ensure that the chimney/flue is structurally sound, so that combustion products do NOT come into contact with combustible materials outside the chimney.
- i. Check for any signs of Down Draught issues with the Installation and any surrounding properties as this could affect the safe operation of the fire. If this is considered a possibility we would recommend the use of a Specialized Down Draught Rotating Terminal, however be aware that these may not protect against all Down Draught situations.
- j. If a Wall Mounted Television is being considered check the wall above the existing builders opening for signs of overheating.
- k. **CHECK FLUE PULL.** Apply a smoke match or smoke generator to the flue opening at hearth level and observe smoke. If there is a definite flow into the flue aperture, proceed with installation. If there is not a definite flow into the flue aperture, preheat the flue for approximately 10 minutes and re-test. There may also be a lack of ventilation so consider opening a window slightly to see if this results in acceptable clearance. If there is not a definite flow towards the flue aperture the flue may need attention.  
**DO NOT FIT THE APPLIANCE, SEEK EXPERT ADVICE.**

## 10. VENTILATION

- a. No additional purpose provided ventilation is normally required for the fire when installed in the UK; however this **must** be confirmed by the Spillage Test, see Section 15.2.
- b. For other Countries refer to National Regulations and Local Codes.
- c. This appliance is fitted with an oxygen depletion sensing system, which automatically shuts off the gas supply to the fire if the oxygen level in the room is depleted, due to lack of primary air, or obstructed flue that would lead to incomplete combustion of the gas. It **must not** be tampered with and only replaced with a genuine Nu-Flame ODS Pilot.

## 11. GAS SUPPLY

**It Is Recommended to Check The Next Section as Building Work May Affect the Gas Supply Routing.**

- a. Carry out a gas soundness test before working on the gas supply.
- b. Gas supply provision should be made in accordance with the latest Gas Safety (Installation and Use) Regulations as amended.
- c. Confirm that the fire has been supplied for the correct gas to be used by checking the Data Badge in the base of the fire.
- d. A route for a concealed gas supply is provided through a hole in the rear of the fire, at a position of 165mm to the left of the centre of the fire and 38mm up from the base of the Builders opening. An isolation elbow is provided at the control inlet.
- e. Where the gas supply passes through walls, floors, voids, concrete and wall cavities the supply should be sleeved.
- f. Determine the gas supply pipe size required taking into account any other gas appliances.
- g. Determine where the gas supply pipe needs to terminate and fit the 8mm compression isolation/pressure test elbow provided.
- h. In common with all other gas appliances, dirt and debris in the gas system can block the valve and gas injectors on this appliance, and faults caused by this are not covered by the guarantee.  
Therefore it is important that all gas pipes **must** be purged of both air and debris.
- i. If you suspect that there may still be dirt and/or debris in the gas system, fit a filter in the pipeline, before the gas isolation/pressure test elbow.
- j. Do **not** use jointing compound on any compression fittings on the fire. The use of jointing compound on the compression joints on this appliance will possibly invalidate the guarantee, as it can get into the control mechanism and cause a malfunction.
- k. Seal off the isolation/pressure test elbow and check all gas connections for gas soundness before proceeding to fit the fire.

**! IMPORTANT NOTE !** Always reseal the pressure test point and check that it is gas tight.

(This accounts for a lot of recalls.)

**Sections 11 - 14 Detail Various Installation Options - Only one will apply.**

**! IMPORTANT NOTE !** *The chosen installation should have been predetermined with any parts ordered before any Building Work Is Started or Installation of the fire. If a Wall Mounted Television is Being Considered Read Section 16 First.*

**The Installation Options Are:**

- 12.0 Hole in the Wall Installation For Steel & Glass Trims (using Sealing Frames) - Options: Requirements for Builders Opening and Combustible or Non Combustible Shelves.
- 13.0 Hole in the Wall Installation For Echo Trims - Options: Requirements for Builders Opening and Combustible or Non Combustible Shelves.
- 14.0 Hole in the Wall Installation (when using marble, slate or stone slips) - Options: Requirements for Builders Opening and Combustible or Non Combustible Shelves.
- 15.0 Fire Surround Installation - Options: Requirements for Builders Opening and Combustible or Non Combustible Shelves/Mantels.
- 16.0 Installation for a Wall Mounted Televisions - With Options Above.

**IMPORTANT : ALL RELEVANT SECTIONS SHOULD BE CONSIDERED BEFORE ANY BUILDING WORK.**

**12. HOLE IN THE WALL INSTALLATION (USING SEALING FRAMES)**

**ONLY APPLIES TO SYNERGY ELLESSE CF STEEL & GLASS WITH SEALING FRAME**

**NOTE: THE STEEL TRIM STYLE CANNOT BE WALL MOUNTED WITH A WALL MOUNTED TELEVISION HOWEVER THE GLASS TRIM STYLE WITH GLASS SHELF & TV SHELF ARE SUITABLE SEE SECTION 16**

**12.1 - SEALING FRAME & WALL COVERINGS**

With any form of heating appliance convection air will rise up through the fire carrying particles of dust that will in time result in varying degrees of wall staining. The Nu-Flame Sealing Frames (& for Synergy Ellesse CF Glass the Glass Shelf) are designed to minimise this by deflecting the airflow away from the wall. However, over time some staining might occur and we therefore suggest not using patterned paper around the fire.

Due to the heat output of The Synergy Range it is not recommended to use blown vinyl wall covering around the fire.

**12.2 HOLE IN THE WALL APPLICATION (FOR STEEL & GLASS TRIMS WITH SEALING FRAMES)**

**BUILDERS OPENING (MINIMUM SIZES) FOR HOLE IN THE WALL APPLICATION (USING SEALING FRAME)**

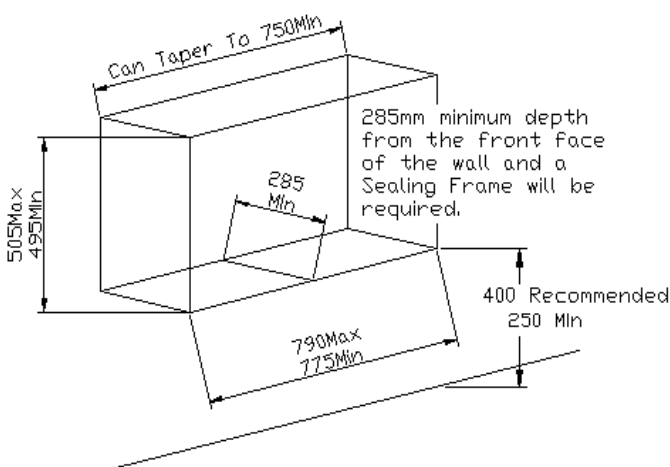

**Notes**

**At 285mm deep a Sealing Frame Will be Required**

**The builders opening can taper towards the back to a minimum of 750mm and must be 285mm deep.**

- a. It is recommended that a qualified builder constructs the builders opening.
- b. It is recommended that a lintel is fitted above the builders opening, structural checks may be required.
- c. The builders opening must be constructed from Non-combustible materials.
- d. **No** combustible materials must present in the builders opening.
- e. The base of the builders opening must be flat, level and square to the wall.
- f. The builders opening should have provision for a gas supply through the rear, see Section 11 Gas Supply.
- g. There must be a flat surface around the face of the builders opening as detailed in Section 8b and is dependant on the Trim Style. This is essential in order to achieve a good seal between the wall and the sealing frame.
- h. The **recommended** height for the base of the Builders Opening is 400mm above floor level. The **minimum** height for the base of the Builders Opening is 250mm above floor level.
- i. The fire is fitted with Electronic Equipment, which is sensitive to dampness and high humidity so it is very **important** that any rendering/building work is allowed to thoroughly dry out before Installation.

**! IMPORTANT !** Dry lined walls – ensure that any air gaps between the back of the plasterboard and wall are sealed around the builders opening or fireplace as this can affect flue pull and wall staining.

### 12.3 – CLEARANCES TO SHELVES & COMBUSTIBLE MATERIALS

- a. We do not recommend the use of combustible shelves in this application.\*
- b. We do not recommend the use of a **non-combustible** shelf in this application. However, see section 13 which shows the application where a **non-combustible** shelf is used.\*
- c. Any combustible sidewall must be at least 500mm from the inside of the builders/fireplace opening.
- d. With all heating appliances, soft furnishings, decorations and wall coverings may discolour or scorch if placed too close.
- e. No combustible material, e.g. curtains must be closer than 500mm to the builders opening.

\*The wall between the sealing frame and any shelf would become hot. Therefore, we do not recommend any shelves with this type of installation.

### 12.4 - FITTING THE FIREBOX

- a. It is very important that the sealing frame makes a good seal against the wall to ensure the fire can seal against the Sealing Frame. There is silicone sponge sealing strip already affixed to the relevant surfaces of both items to ensure a good seal. Ensure this silicone sealing strip stays in place during installation.
- b. Secure the Sealing Frame to the wall with the screws and rawplugs provided ensuring it is positioned centrally in the Builders Opening.
- c. Make sure that the silicone sealing strip stays in position, around the flange on the Sealing Frame, to create a seal to the wall around the builders opening.
- d. If the silicone sealing strip is not compressed and there are gaps they must be filled with a suitable sealant, fireclay or high temperature silicone. Wall staining may occur if the seals are not compressed and the flue draw will be compromised.
- e. Slide the Fire **part way** through the Sealing Frame (leaving it sticking out approximately 50mm) ensuring the gas supply pipe and isolation/pressure test elbow clears through the cut out in the rear of the Fire and does not foul on the control.
- f. Lift the Fire slightly and slide it home ensuring that the sealing strip along the front edge of the underside of the Fire stays in position to make a seal between the Fire and the sealing frame.
- g. Ensure that the silicone sealing strip on the rear of the Fire outer frame stays in position to create a good seal between the Fire and the Sealing Frame.
- h. Secure the Fire to the Sealing Frame with the screws provided.
- i. Refit the burner mounting plate assembly by first putting the Receiver through the opening then tilt the assembly and slide it into the fire and secure with the 4 screws. Take care not to mark the liners in the fire. Place the Receiver to the left side at the front.
- j. Connect the isolation/pressure test elbow to the control valve and with it fully open check the joint for gas soundness.
- k. Check that all gas connections are sound. The appliance has been factory tested; however the connections may have been disturbed in transit or storage.

**! IMPORTANT NOTE !** Always reseal the pressure test point and check that it is gas tight. (This accounts for a lot of recalls.)

## 13. HOLE IN THE WALL INSTALLATION

### ONLY APPLIES TO SYNERGY ELLESSE CF WITH ECHO TRIMS

If a Wall Mounted Television is being Considered Also Make Reference to Section 16

#### 13.1 - WALL COVERINGS

With any form of heating appliance convection air will rise up through the fire carrying particles of dust that will in time result in varying degrees of wall staining. The Nu-Flame Sealing Frames are designed to minimise this by deflecting the airflow away from the wall. However, over time some staining might occur and we therefore suggest not using patterned paper around the fire.

#### 13.2 HOLE IN THE WALL APPLICATION (FOR ECHO TRIMS)

##### BUILDERS OPENING (MINIMUM SIZES) FOR HOLE IN THE WALL APPLICATION (USING SEALING FRAME)

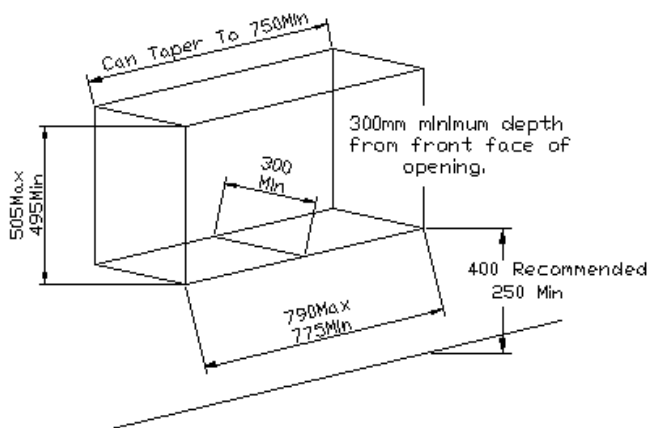

- It is recommended that a qualified builder constructs the builders opening.
- It is recommended that a lintel is fitted above the builders opening, structural checks may be required.
- The builders opening must be constructed from Non-combustible materials.
- No combustible materials must present in the builders opening.
- The base of the builders opening must be flat, level and square to the wall.
- The builders opening should have provision for a gas supply through the rear, see Section 11 Gas Supply.
- There must be a flat surface around the face of the builders opening as detailed in Section 8b and is dependant on the Trim Style. This is essential in order to achieve a good seal between the wall and the sealing frame.
- The **recommended** height for the base of the Builders Opening is 400mm above floor level. The **minimum** height for the base of the Builders Opening is 250mm above floor level.
- The fire is fitted with Electronic Equipment, which is sensitive to dampness and high humidity so it is very **important** that any rendering/building work is allowed to thoroughly dry out before Installation.

**Note:** The builders opening can taper towards the back to a minimum of 750mm and must be 300mm deep.

**! IMPORTANT !** Dry lined walls – ensure that any air gaps between the back of the plasterboard and wall are sealed around the builders opening or fireplace as this can affect flue pull and wall staining.

#### 13.3 – CLEARANCES TO SHELVES & COMBUSTIBLE MATERIALS

- We do not recommend the use of combustible shelves in this application.\*
- We do not recommend the use of a **non-combustible** shelf in this application. However, see the diagram in section 13.4 which shows the application where a **non-combustible** shelf is used.\*
- Any combustible sidewall must be at least 500mm from the inside of the builders/fireplace opening.
- With all heating appliances, soft furnishings, decorations and wall coverings may discolour or scorch if placed too close.
- No combustible material, e.g. curtains must be closer than 500mm to the builders opening.

\*The wall between the sealing frame and any shelf would become hot. Therefore, we do not recommend any shelves with this type of installation.

#### 13.4 - FITTING THE FIREBOX & USING THE CABLE FIXING SYSTEM

Reference should be made to the illustrations on the next page.

- There is silicone sponge sealing strip already affixed to the relevant surfaces to ensure a good seal. Ensure this silicone sealing strip stays in place during installation.
- A cable fixing system is supplied to secure the unit into the Builders Opening. The cable fixing system will also pull the unit tight back against the slips to make a good seal. This is very important to ensure efficient operation of the fire.
- There are 2 cables supplied; 1 to be used each side of the unit. Working at 510mm centres in the builders opening drill the lower holes 20mm up from the base and drill the higher holes 460mm up from the base - see drawing on below. Secure the 4 Eyebolts supplied with the Rawlplugs to the back of the fireplace. Ensure the Eyebolts are fully screwed in.
- There are 2 cable attachment point tabs on the top of the main casing; 1 each side at the rear. They are part of the folded lip of the top section prize these up with a screwdriver to enable them to be used. Feed a cable downwards through the hole in the tab.
- Taking care to not damage the slips, rest the Fire in the builders opening so that you can still gain access to the cables and eyebolts. Feed the cables through the eyebolts on either side and then through the hole in the back of the fire near the base
- Slide the Fire **part way** into the Builders Opening (leaving it sticking out approximately 50mm) ensuring the gas supply pipe and isolation/pressure test elbow clears through the cut out in the rear of the Main Casing and does not foul on the control.
- Lift the Fire slightly and slide it home ensuring that the sealing strips on the underside of the front of the Fire and the rear of the Fire outer frame stay in position to make a seal against the top edge of the slip at the base of the builders opening and the front face of the slips where they locate against the rear of the Fire outer frame. While sliding the unit into the Builders Opening pull on the excess cable.

- h. Referring to the illustrations below feed the cables through the two loose cable clamp brackets. The adjuster and lock screw can now be fitted onto the cable and through the large hole in the cable clamp bracket. Position the brackets one either side of the fire towards the bottom of the channel between the Main Casing and the Inner Fire Casing. By use of the adjuster and lock screw tighten up the cable to tension the fire back into the fireplace. The fire should be secure and not liable to movement. *Surplus fixing cable MUST NOT be cut off and must be tucked back through the small hole in the cable clamp bracket to keep it well away from any electronics.*
- i. If any of the silicone sealing strips are not compressed and/or if there are gaps they must be filled with a suitable sealant, fireclay or high temperature silicone.
- j. Refit the burner mounting plate assembly by first putting the Receiver through the opening then tilt the assembly and slide it into the fire and secure with the 4 screws. Take care not to mark the liners in the fire. Place the Receiver to the left side at the front.
- k. Connect the isolation/pressure test elbow to the control valve and with it fully open check the joint for gas soundness.
- l. Check that all gas connections are sound. The appliance has been factory tested; however the connections may have been disturbed in transit or storage.

**! IMPORTANT NOTE !** Always reseal the pressure test point and check that it is gas tight. (This accounts for a lot of recalls.)

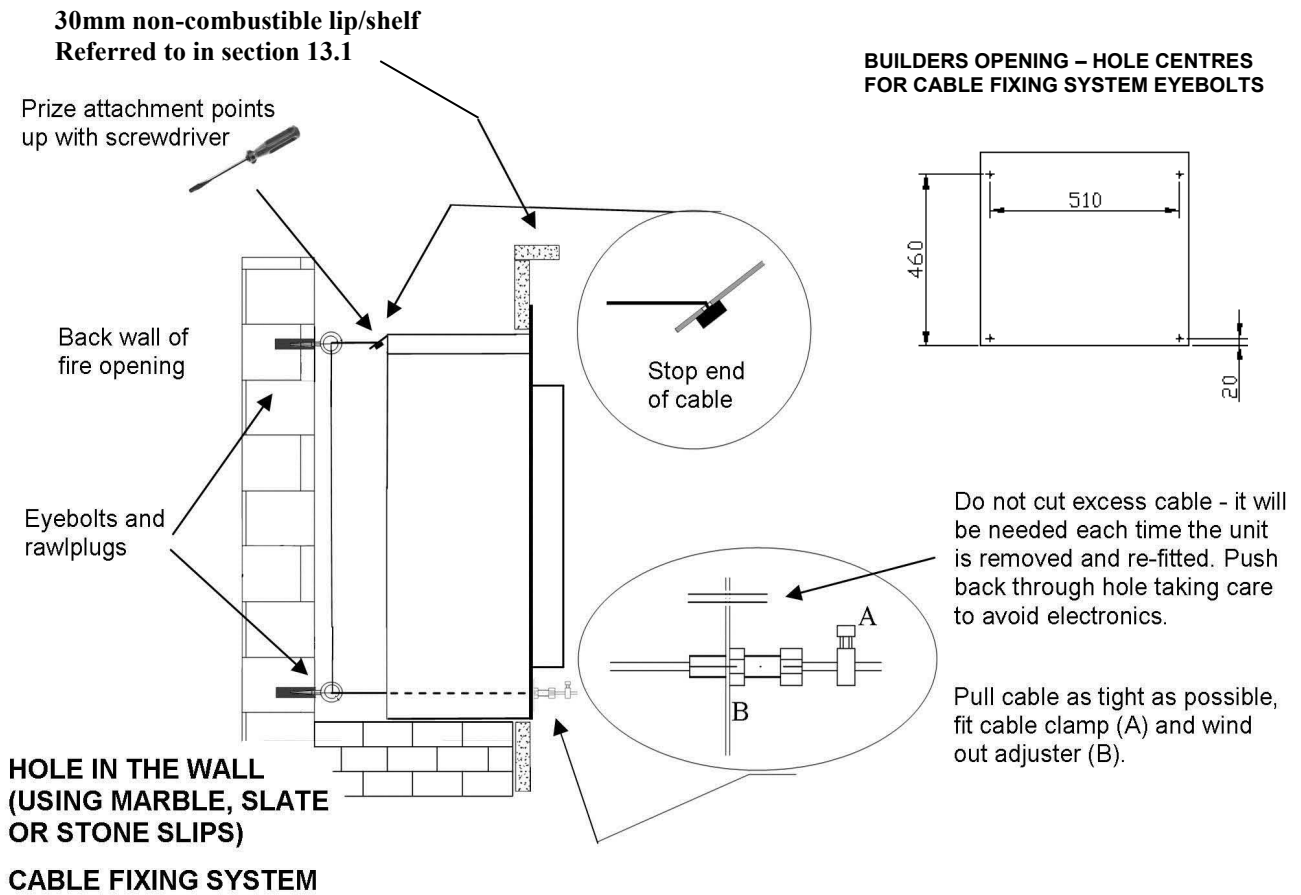

**NOTE: Tensioning nut wound fully back to allow maximum adjustment**



**FINISHED & ADJUSTED**  
Do not over tighten - just enough to seal

## 14. HOLE IN THE WALL INSTALLATIONS - WHEN USING MARBLE, SLATE OR STONE SLIPS If a Wall Mounted Television is being Considered Also Make Reference to Section 16

This Hole in the Wall Application is suitable for all Trim Models without a Sealing Frame however for the Synergy Ellesse CF Glass Trim Option the Glass Shelf Must be used.

### 14.1 - SLIPS & WALL COVERINGS

It is essential to use marble, slate or stone slips, fitted around the builders opening. The slips must have a temperature rating of 150°C and we recommend that they form a border around the fire of at least 100mm see Section 7b to determine the Slip sizes to match the Trim being used. In order to direct the flow of heated air away from the wall with the Steel or Glass Trims Options we recommend that a non combustible shelf (lip) is also fitted above the top slip, protruding 30mm – see diagram in section 13.4.

With any form of heating appliance convection air will rise up through the fire carrying particles of dust that will in time result in varying degrees of wall staining. The non-combustible shelf is designed to minimise this by deflecting the airflow away from the wall. However, over time some staining might occur and we therefore suggest not using patterned paper around the fire.

Due to the heat output of The Synergy Range it is **not recommended** to use blown vinyl wall covering around the fire.

Where the Chimney Breast is made of Stone, Slate or other Suitable Non Combustible Material with NO wall coverings then Slips are Not Required but the Dimensions of the Builders Opening must be as shown below and a Flat Surface as detailed in Section 8b will be required for the Trim Option being considered to allow the Trim to be fitted and provided a flat area around the opening for sealing.

In this Application as Slips are being used we supply a Cable Fixing System as Drill Fixing may result in cracking of the slips, which may not show until the fire as got hot and then cooled down over a number of operations.

**Nu-Flame will not accept responsibility for Cracked Slips due to Drill Fixing.**

### 14.2 HOLE IN THE WALL APPLICATION (WHEN USING MARBLE SLATE OR STONE SLIPS)

#### BUILDERS OPENING FOR HOLE IN THE WALL APPLICATION (WHEN USING MARBLE, SLATE OR STONE SLIPS)

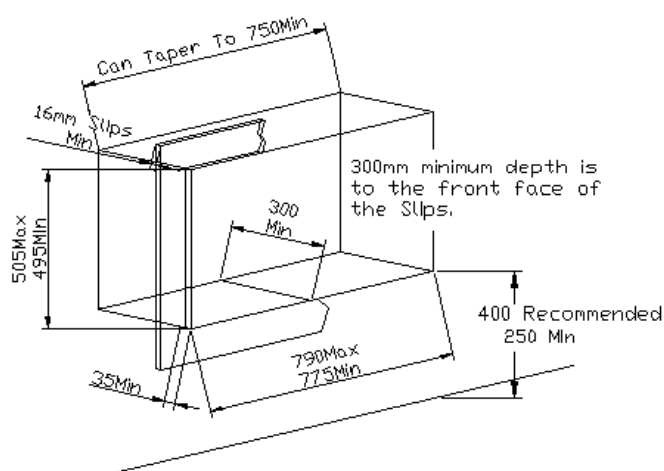

- It is recommended that a qualified builder constructs the builders opening.
- It is recommended that a lintel is fitted above the builders opening, structural check may be required
- The builders opening must be constructed from Non-combustible materials.
- No** combustible materials must present in the builders opening.
- The base of the builders opening must be flat, level and square to the wall.
- The builders opening should have provision for a gas supply through the rear, see Section 11 Gas Supply.
- There must be a flat surface around the builders opening of sufficient area to enable the slips to be securely fitted. The slips should be fitted to the wall in such a way that they form a seal to stop air from the room being drawn behind the slips into the builders opening. We recommend a high temperature silicon sealant.
- The **recommended** height for the base of the Builders Opening is 400mm above floor level. The **minimum** height for the base of the Builders Opening is 250mm above floor level.
- The fire is fitted with Electronic Equipment, which is sensitive to dampness and high humidity so it is very **important** that any rendering/building work is allowed to thoroughly dry out before Installation.

**Note: The builders opening can taper towards the back to a minimum of 750mm and must be 300mm deep.**

**! IMPORTANT !** Dry lined walls – ensure that any air gaps between the back of the plasterboard and wall are sealed around the builders opening or fireplace as this can affect flue pull and wall staining.

**! IMPORTANT !** When fitting the slips ensure they are flush and form a flat surface around the builders opening.

### 14.3 - CLEARANCES TO SHELVES & COMBUSTIBLE MATERIALS

- We do not recommend the use of a combustible shelf in this application.
- We do not recommend the use of a non-combustible shelf in this application other than the non combustible shelf /lip mentioned in section 13.1 and the diagram shown in 13.4.
- Any combustible sidewall must be at least 500mm from the inside of the builders/fireplace opening.
- With all heating appliances, soft furnishings, decorations and wall coverings may discolour or scorch if placed too close.
- No combustible material, e.g. curtains must be closer than 500mm to the builders opening.



## 14.4 - FITTING THE FIREBOX & USING THE CABLE FIXING SYSTEM

Reference should be made to the illustrations below.

- There is silicone sponge sealing strip already affixed to the relevant surfaces to ensure a good seal. Ensure this silicone sealing strip stays in place during installation.
- A cable fixing system is supplied to secure the unit into the Builders Opening. The cable fixing system will also pull the unit tight back against the slips to make a good seal. This is very important to ensure efficient operation of the fire.
- There are 2 cables supplied; 1 to be used each side of the unit. Working at 510mm centres in the builders opening drill the lower holes 20mm up from the base and drill the higher holes 460mm up from the base - see drawing on below. Secure the 4 Eyebolts supplied with the Rawplugs to the back of the fireplace. Ensure the Eyebolts are fully screwed in.
- There are 2 cable attachment point tabs on the top of the main casing; 1 each side at the rear. They are part of the folded lip of the top section prize these up with a screwdriver to enable them to be used. Feed a cable downwards through the hole in the tab.
- Taking care not to damage the slips, rest the Fire in the builders opening so that you can still gain access to the cables and eyebolts. Feed the cables through the eyebolts on either side and then through the hole in the back of the fire near the base
- Slide the Fire **part way** into the Builders Opening (leaving it sticking out approximately 50mm) ensuring the gas supply pipe and isolation/pressure test elbow clears through the cut out in the rear of the Main Casing and does not foul on the control.
- Lift the Fire slightly and slide it home ensuring that the sealing strips on the underside of the front of the Fire and the rear of the Fire outer frame stay in position to make a seal against the top edge of the slip at the base of the builders opening and the front face of the slips where they locate against the rear of the Fire outer frame. While sliding the unit into the Builders Opening pull on the excess cable.
- Referring to the illustrations below feed the cables through the two loose cable clamp brackets. The adjuster and lock screw can now be fitted onto the cable and through the large hole in the cable clamp bracket. Position the brackets one either side of the fire towards the bottom of the channel between the Main Casing and the Inner Fire Casing. By use of the adjuster and lock screw tighten up the cable to tension the fire back into the fireplace. The fire should be secure and not liable to movement.  
*Surplus fixing cable MUST NOT be cut off and must be tucked back through the small hole in the cable clamp bracket to keep it well away from any electronics.*
- If any of the silicone sealing strips are not compressed and/or if there are gaps they must be filled with a suitable sealant, fireclay or high temperature silicone.
- Refit the burner mounting plate assembly by first putting the Receiver through the opening then tilt the assembly and slide it into the fire and secure with the 4 screws. Take care not to mark the liners in the fire. Place the Receiver to the left side at the front.
- Connect the isolation/pressure test elbow to the control valve and with it fully open check the joint for gas soundness.
- Check that all gas connections are sound. The appliance has been factory tested; however the connections may have been disturbed in transit or storage.

**IMPORTANT NOTE !** Always reseal the pressure test point and check that it is gas tight. (This accounts for a lot of recalls.)

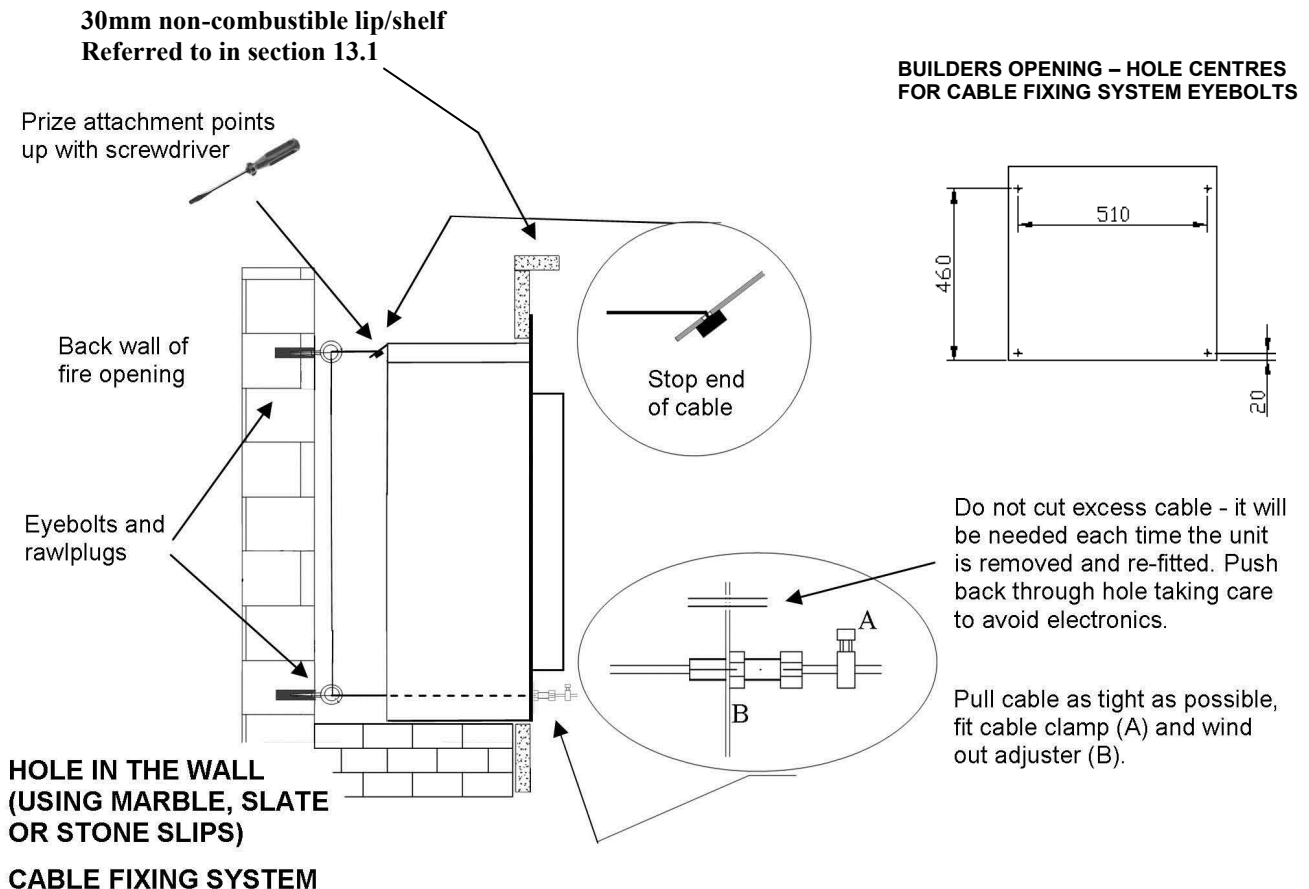

**NOTE:** Tensioning nut wound fully back to allow maximum adjustment

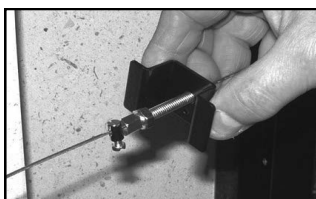

**FINISHED & ADJUSTED**  
Do not over tighten - just enough to seal

## 15. FIRE SURROUND INSTALLATIONS - Steel & Glass Trim Options with Riser Plate

If a Wall Mounted Television is being Considered Also Make Reference to Section 16

The Echo Trim Style is Not considered suitable for a Traditional Fire Surround and will require a Bespoke Design.  
Any design should allow for a 150mm minimum deep shelf if a Wall Mounted Television is being considered.

This Application does not require the Sealing Frames & with the Synergy Ellesse CF Glass, the Glass Shelf.

For This Application a Riser Plate is Fitted That Raises The Fire To Enable The Door To Be Opened  
Therefore The Fireplace Opening is 30mm Higher.

In this Application as a fire surround is being used we supply a Cable Fixing System as Drill Fixing may result in cracking of the back panel, which may not show until the fire has got hot and then cooled down over a number of operations.

**Nu-Flame will not accept responsibility for Cracked Back Panels due to Drill Fixing.**

### 15.1 FIRE SURROUND APPLICATIONS

#### CUTOUT SIZE FOR FIRE SURROUND APPLICATION

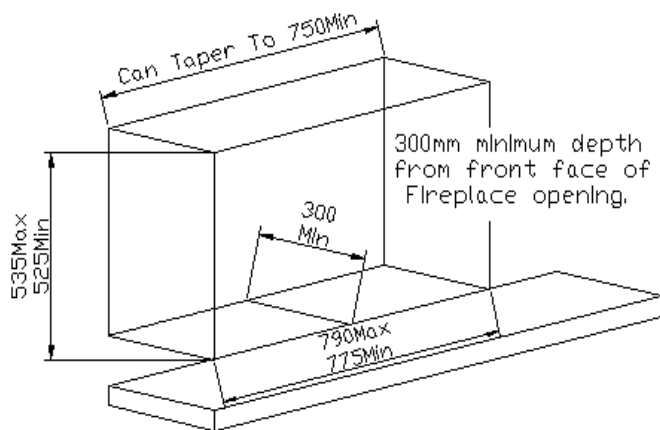

#### FIREPLACE CONSTRUCTION

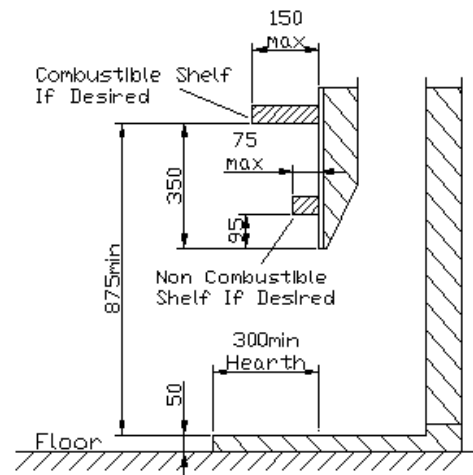

**Notes:** There must be no combustible materials inside the builders opening.

The builders opening can taper towards the back to a minimum of 750mm and must be 300mm deep.

### 15.2 - FIRE SURROUND REQUIREMENTS

- If the Fire is to be fitted into a purpose made Fire Surround it must have a temperature rating of 150°C. Take care with some micro marbles and the adhesives used claiming 150°C rating as they can be prone to blistering and can give off odour.
- The Fire requires a non-combustible hearth of at least 12mm thick.
- The surface of the hearth must stand at least 50mm above the floor and level with the fireplace opening.
- The hearth must project at least 300mm in front of the fireplace opening and 150mm either side (1080mm minimum width).
- The base of the fireplace must be flat, level and square to the face of the fireplace opening.
- There can be **no** up stand around the hearth as the door of the fire has to be opened.
- The surround must cater for a minimum flat surface around the Fireplace Opening allowing 100mm above the opening and 125mm on each side. This is essential in order to achieve a good seal between the face of the Surround back panel and the Fire sealing Flange.
- The fire is fitted with Electronic Equipment, which is sensitive to dampness and high humidity so it is very **important** that any rendering/building work is allowed to thoroughly dry out before Installation.

**! IMPORTANT !** Dry lined walls – ensure that any air gaps between the back of the plasterboard and wall are sealed around the builders opening or fireplace as this can affect flue pull and wall staining.

### 15.3 - CLEARANCES TO SHELVES & COMBUSTIBLE MATERIALS (Ref: Diagram Above)

- A **non combustible** shelf can be fitted above the fire and should be positioned at least 95mm above the builders opening. We recommend the depth of the shelf should be a maximum of 75mm as anything deeper will reduce convection air and the efficiency of the fire. For deeper non-combustible shelves they must be raised a further 25mm for every extra 25mm of depth.
- A 150mm **combustible** shelf can be fitted above the fire but must be positioned at least 350mm above the builders opening. (1025mm minimum from base of fireplace opening). For deeper combustible shelves they must be raised a further 25mm for every extra 25mm of depth.
- Any combustible sidewall must be at least 500mm from the inside of the builders/fireplace opening, however with a combustible fire surround it can be 150mm from the inside of the builders/fireplace opening provided it does not protrude more than 150mm and must be increased by 25mm for every extra 25mm of depth.
- With all heating appliances, soft furnishings, decorations and wall coverings may discolour or scorch if placed too close.
- No combustible material, e.g. curtains must be closer than 500mm to the builders opening.
- Any combustible wall claddings (wall paper) must be cut back to the perimeter of the shelf and slips or to a height of 875mm and 140mm either side of the Fireplace Opening.

## 15.4 - FITTING THE FIREBOX (With Riser Plate)

Reference should be made to the illustrations below.

- There is silicone sponge sealing strip already affixed to the relevant surfaces to ensure a good seal. Ensure this silicone sealing strip stays in place during installation.
- When used in a fireplace the Fire is supplied with two factory-fitted 30mm riser channels which are required to raise the fire to allow convection and cooling air to the appliance.
- A cable fixing system is supplied to secure the unit into the fireplace. The cable fixing system will also pull the unit tight back into the fireplace to make a good seal. This is very important to ensure efficient operation of the fire.
- There are 2 cables supplied; 1 to be used each side of the unit. Working at 510mm centres in the builders opening drill the lower holes 50mm up from the base and drill the higher holes 460mm up from the base see drawing below. Secure the 4 Eyebolts supplied with the Rawplugs to the back of the fireplace. Ensure the Eyebolts are fully screwed in.
- There are 2 cable attachment points on the top of the main casing; 1 each side at the rear. They are part of the folded lip of the top section prize these up with a screwdriver to enable them to be used. Feed a cable downwards through each cable attachment point.
- Protect the hearth against scratching with cardboard or a dust sheet and position the Fire on the protected hearth.
- Feed the cables through the eyebolts on either side and then through the hole in the back of the fire near the base
- Slide the Fire **part way** into the fireplace (leaving it sticking out approximately 50mm) ensuring the gas supply pipe and isolation/pressure test elbow clears through the cut out in the rear of the Fire and does not foul on the control.
- Lift the Fire slightly and slide it home ensuring that the sealing strips on the underside of the front riser channel and the rear of the Fire outer frame stay in position to make a seal against the base of the fireplace and the fireplace back panel. While sliding the unit into the fireplace opening pull on the excess cable.
- Referring to the illustrations below feed the cables through the two loose cable clamp brackets. The adjuster and lock screw can now be fitted onto the cable and through the large hole in the cable clamp bracket. Position the brackets one either side of the fire towards the bottom of the channel between the Main Casing and the Inner Fire Casing. By use of the adjuster and lock screw tighten up the cable to tension the fire back into the fireplace. The fire should be secure and not liable to movement.  
*Surplus fixing cable MUST NOT be cut off and must be tucked back through the small hole in the cable clamp bracket to keep it well away from any electronics.*
- If any of the silicone sealing strips are not compressed and/or if there are gaps they must be filled with a suitable sealant, fireclay or high temperature silicone.
- Refit the burner mounting plate assembly by first putting the Receiver through the opening then tilt the assembly and slide it into the fire and secure with the 4 screws. Take care not to mark the liners in the fire. Place the Receiver to the left side at the front.
- Connect the isolation/pressure test elbow to the control valve and with it fully open check the joint for gas soundness.
- Check that all gas connections are sound. The appliance has been factory tested; however the connections may have been disturbed in transit or storage.

**! IMPORTANT NOTE !** Always reseal the pressure test point and check that it is gas tight. (This accounts for a lot of recalls.)

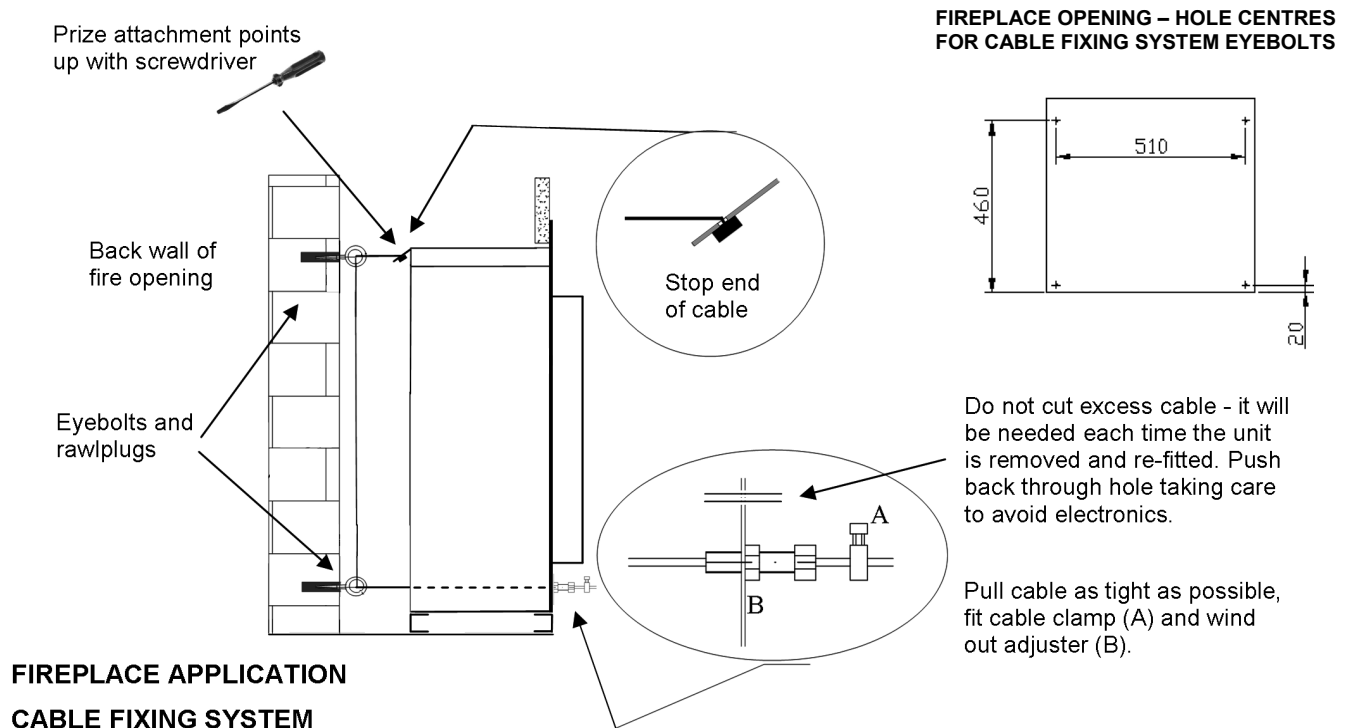

**NOTE:** Tensioning nut wound fully back to allow maximum adjustment

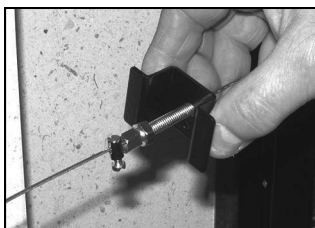

**FINISHED & ADJUSTED**  
Do not over tighten - just enough to seal



## 16. INSTALLATION INSTRUCTIONS FOR WALL MOUNTED TELEVISIONS ADDITIONAL REQUIREMENTS

**IMPORTANT: THE STEEL TRIM OPTION WHEN WALL MOUNTED IS NOT SUITABLE FOR A WALL MOUNTED TELEVISION.**

These Instructions detail the Installation Requirements for Wall Mounted Televisions when Installed above the Fire and should be considered with all other Installation Requirements of the Fire.

**IMPORTANT: Due to the High Heat Output of the Fire The Installation Requirements of these Instructions MUST be Adhered To For Wall Mounted Televisions.**

**IMPORTANT: The Fire and Trim Style will affect the height and position of the Television therefore it is important to check what height position options are possible and acceptable.**

### 16.1 - GENERAL

Before continuing with the Television Installation it is important to determine if there is the likelihood of the Chimney Breast becoming hot when the Fire is in operation. Some of these checks will only provide assistance if a fire has been previously installed. The following checks will assist but are not conclusive.

- Typically Class 1 flues with Dry Lined Walls will normally have acceptable Wall Temperatures provided the air gap is fully sealed around the builders opening.
- If a gas fire was installed and the chimney breast shows any signs of over heating e.g. discoloured wall paper, then do not consider Installing a Wall Mounted Television as the Temperatures are likely to be too high.
- If a gas fire was installed and the Chimney Breast is finished in Wall Paper and shows no signs of temperature damage then the Wall Temperatures are likely to be acceptable so the Installation can proceed.
- A Wall Mounted Television Must Not be sunk into the wall as it will not be in an acceptable ventilated position and this is only acceptable if additional fan cooling ventilation is provided. It is also likely that higher temperatures from the flue within the Chimney Breast will occur.
- The Wall Mounted Television must be mounted on a suitable bracket or angled bracket that meets the Television Manufacturer's requirements and spaces the Television at least 35mm away from the Chimney Breast.
- After reading the Installation Requirements you should compare this with the preferred height position of the Television.

### 16.2 - TELEVISION GLASS HEAT SHIELD INSTALLATION REQUIREMENTS

Reference Must Also Be Made to the Installations Requirements for Each Type of Trim as Detailed on the Following Pages Where the Installation requires the fitting of the Television Glass Heat Shield the following instructions apply.

**Important** - Before proceeding with the Installation of the Television Heat Shield confirm the preferred Height Position of the Television with the Customer.

- It is recommended that, for aesthetic reasons, due consideration is given prior to Installation for the provision of mains electric, aerial, sound and any other Connections that may wish to be hidden behind the Television.  
A Qualified Electrician/Specialist should be consulted.
- Reference should be made to the diagram below for the position of the hole fixings which should be above the minimum height as shown in the different Installation Requirements on the following pages.
- Determine the height position to the base of the Television Heat Shield from the relevant Installation Diagrams on the next page and draw a line for reference ensuring it is level.
- Mark out the holes as shown in the diagram but before drilling recheck your dimensions ensuring the height of the Television is correct and the distances will be as required.
- Before drilling the holes check for the positions of any wires within the wall
- Ensure the wall is sound and the fixings will be secure for the Television Heat Shield before proceeding with fitting.

**Television Heat Shield Fixing Hole Centres  
Ensure the Base is at the Correct Distance**

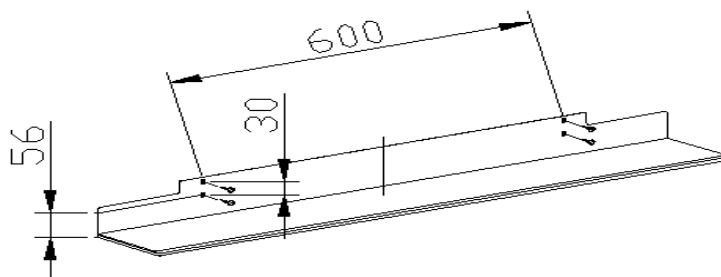

## 16.3 - TELEVISION INSTALLATION REQUIREMENTS FOR WALL MOUNTED FIRES SYNERGY ELLESSE CF GLASS TRIMS

**Note:** The Fire Must have been specified for a Wall Mounted Installation and for Use with a Wall Mounted Television.

The Fire should have then been Supplied With a Glass Shelf and Television Glass Heat Shield.  
**Important :** These Parts Must Be Obtained before the Installation can be started.

**Important:** Due to the High Heat Output of the Synergy Range The Installation Requirements of these Instructions Must Be Adhered To For Wall Mounted Television Applications.

**Important:** Taking account of the minimum distance requirements in the diagrams below it is important that the preferred position for the Television is determined before any building work is carried out.

- The Temperature above the Wall Mounted Fire with Glass Shelf and Television Glass Heat Shield have been verified by BSI to provide an actual Ambient Temperature of 90° Fahrenheit (32° Centigrade) when the Synergy is Installed as detailed in the Fire's Installation Instructions and the Installation meets the Minimum Dimensions as detailed in the Diagrams below.
- You **Must** take account of the Television Manufacturer's Installation requirements provided within their Instructions.
- The Glass Shelf with Television Glass Heat Shield **Must** always be used if a Television is to be Mounted above the Synergy Range of Gas Fires.
- The preferred height position for a Wall Mounted Television **Must** meet the Installation Requirements of these Instructions.
- The Nu-Flame Television Glass Heat Shield is only suitable for the Nu-Flame Synergy Range of Gas Fires.
- The Television Shelf fixings will be hidden behind the Television so this should be fixed prior to the final fixing.
- Check First for the positions of any wires within the wall before drilling for the fixings.
- The **Minimum** Dimensions for the position of the Television Glass Heat Shield and Television **Must** be used as shown in the diagrams.
- The Television can be Mounted Vertically if desired with a suitable Wall Bracket.
- Alternatively to help provide the preferred viewing position a 15° Angled Wall Mounting Bracket can be used for the Television Installation. A wall bracket with a larger angle **Must Not** be used.
- It is recommended that, for aesthetic reasons, due consideration is given prior to Installation for the provision of mains electric, aerial, sound and any other Connections that you may wish hidden behind the Television.
- Ensure the wall is sound and the wall fixings are secure and able to take the weight of the Television.
- The Glass Shelf and Television Glass Heat Shield ensure thermal protection through the critical central area therefore will still be suitable for Wider televisions, however all other requirements of these instructions must also be adhered too.
- Now Proceed and fit the Television Heat Shield as detailed on the previous page

**Wall Mounted Fire and Television Installations with Glass Trim**

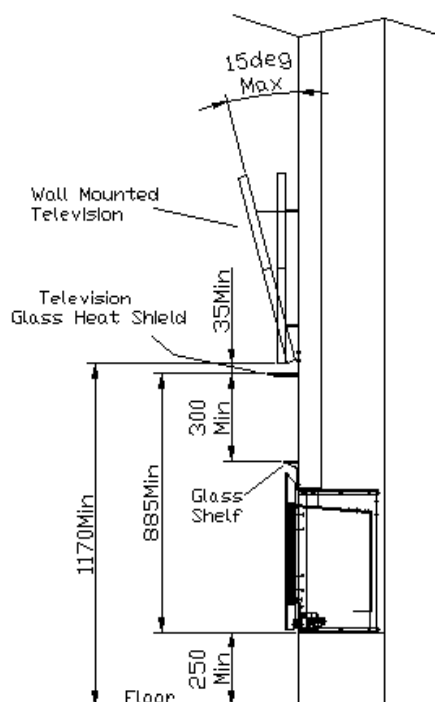

**Wall Mounted Fire and Television Installations with Echo Trim**

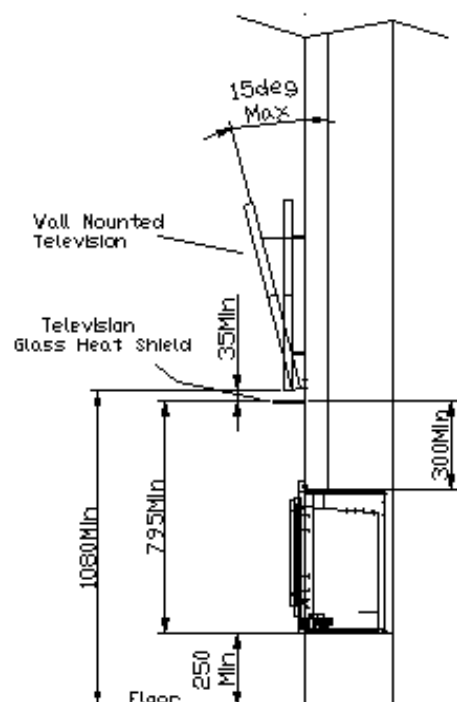

## 16.4 - TELEVISION INSTALLATION REQUIREMENTS FOR FIRES INSTALLED IN FIRE SURROUNDS (Combustible or Non Combustible Fire Surround)

The Echo Trims Styles are Not suitable for a Traditional Fire Surround and will require a Bespoke Design. As part of this design the 150mm minimum deep shelf and minimum height of 100mm must be maintained.

**Note:** The Installation Requirements for Combustible (e.g. Wood Mantel) are different to a Non Combustible (e.g. Stone Surround). Refer to the Relevant Diagram Below.

**Important:** Due to the High Heat Output of the Synergy Range The Installation Requirements of these Instructions Must Be Adhered To For Fire Surrounds with a Wall Mounted Television.

**Important:** Taking account of the minimum distance requirements in the diagrams below it is important that the preferred position for the Television is determined before any building work is carried out.

Provided the shelf of the Fire Surround is at least 150mm deep then a Wall Mounted Television can be wall mounted without a Television Glass Heat Shield or Top Shelf, however we would recommend that the Television is mounted at least 100mm above the Surround.

### Additional Requirements

- The Temperature above a Fire Surround has been verified by BSI to provide an actual Ambient Temperature of 90° Fahrenheit (32° Centigrade) when the Synergy is Installed as detailed in the Fire's Installation Instructions and the Fire Surround meets the Minimum Dimensions as detailed in the Diagrams Below.
- You **Must** take account of the Television Manufacturer's Installation requirements provided within their Instructions.
- The preferred height position for a Wall Mounted TV may only be possible with a specific design of Fire Surround.
- The Fire surround **Must** meet the Minimum Dimensions shown in the Diagrams to be suitable for a Wall Mounted Television.
- The Television can be Mounted Vertically if desired with a suitable Wall Bracket.
- Alternatively to help provide the preferred viewing position a 15° Angled Wall Mounting Bracket can be used for the Television Installation. A wall bracket with a larger angle **Must Not** be used.
- It is recommended that, for aesthetic reasons, due consideration is given prior to Installation for the provision of mains electric, aerial, sound and any other Connections that you may wish hidden behind the Television.
- Check First for the positions of any wires within the wall before drilling for the fixings.
- Ensure the wall is sound and the wall fixings are secure and able to take the weight of the Television.
- The Fire Surround and fixing requirements provided will ensure thermal protection through the critical central area therefore will still be suitable for Wider televisions, however all other requirements of these instructions must also be adhered too.

**Combustible Fire Surround Installation e.g.  
Wood Mantel**

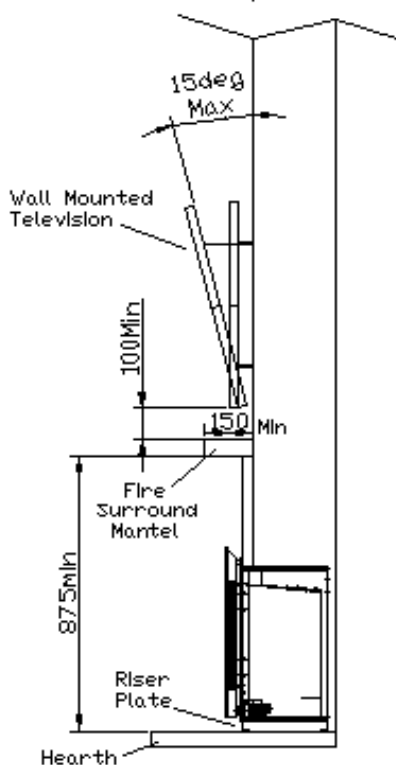

**Non Combustible Fire Surround  
Installation e.g. Stone Mantel**

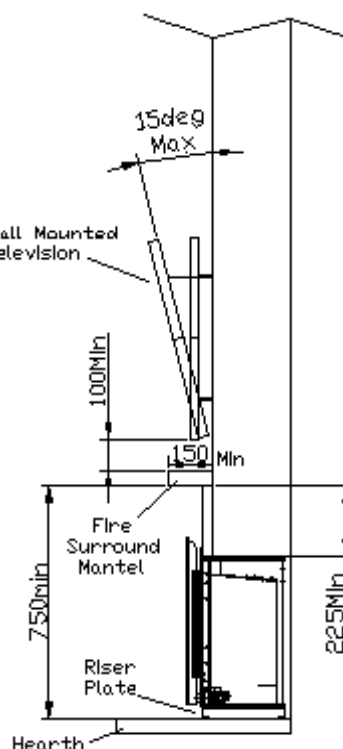

## 17. ARRANGEMENT OF THE FUEL EFFECT (Logs, Vermiculite and Bark Chips).

### Health & Safety Advice Refractory Ceramic Fibre (RCF)

#### Advice when working with Fuel Bed Components including Installing, Servicing and Disposal.

The Fuel Effect parts and possible Linings of this fire are made from Refractory Ceramic Fibre (R.C.F.) a Class 2 Carcinogen which is a material designed for this Application. Excessive exposure to these types of materials may cause temporary irritation to eyes, skin and respiratory tract. Therefore take care when handling these articles to ensure dust is kept to a minimum. It is not necessary to wear protective clothing when handling these articles but we do recommend you follow the normal hygiene rules of not smoking, eating or drinking in the work area, and always wash your hands before eating or drinking. To minimise the release of RCF fibres during installation and servicing a HEPA filtered vacuum is recommended to remove any dust accumulated in and around the fire both before and after working on it. When Servicing and if replacing these parts we do not recommend they are broken up but are sealed within a heavy duty polythene Bag and labelled as "RCF waste". This is not classified as "hazardous waste" and may be disposed of at a local licensed landfill site.

#### The fire is available with either a Dark Log or Silver Birch Log Set and the fitting is the same.

a. Open the Glass Door of the Fire by removing the 2 screws to the left of the door with the Pozidriv screwdriver provided.

b. Ensure the Fuel Tray is in position.

**! TIP !** Ensure the cut-out in the Fuel Tray at the back is positioned over the pilot shield.

**! TIP !** Take care not to damage liner panels with edge of fuel tray.



c. Much of the fire's appearance is achieved by the placement of the Fuel Bed, e.g. Vermiculite, Bark Chips, Embaglow and Logs.

d. Gently shake the bag of vermiculite granules so that the dust settles to the bottom of the bag.  
**Do not use the dust from the bottom of the bag.**

e. Firstly, carefully place natural coloured vermiculite granules (from large bag) into the central tray area on the burner sufficient to fill it to the top (5mm depth). Secondly, sprinkle a small quantity of black vermiculite granules (from small bag) on top, retaining some for later (see 14 section 'o'). Any granules that fall onto the ported (holes) in burner top must be removed. No granules should be left around the pilot area.



f. Carefully remove the Logs from the box; the logs are numbered on the base from 1 to 6. Logs 4, 5 and 6 have holes in the base for location onto the pegs on the fuel tray.

g. Place the large rear log No.1 to the rear of the fire on the fuel tray ensuring that the cut-out in the log sits behind the pilot shield and that it is central about the burner.



h. Place log No.2 on the left so that it sits in the cut out on the rear log and locates on the support at the front.



- i. Place log No.3 next to log no2 so that it sits on its peg and locates in the groove on the rear log.



- j. Working from the right of the fuel tray now place log No.6 so that it rests on the rear log and locates on the log support at the front.



- k. Place log No.5 next to log No.6 locating it on the peg and the cut out in the rear log.



- l. Place the last log No.4 so that it locates on the central peg and rests in the cut outs in logs 3 and 5.



- m. Place the black and sand coloured bark chips around the fuel tray and in the spaces between the logs hiding the metal flange of the fuel tray.  
**Do NOT place any Bark Chips on the Burner.**





- n. Firstly, carefully place the remainder of the natural coloured vermiculite granules (from the large bag) around the bark chips and logs so that none of the fuel tray is visible. Secondly, sprinkle the remainder of the black vermiculite granules (from the small bag) over the same area.



**Ensure that any Vermiculite granules that fall onto the ported (holes) area of the Burner are removed.**

**Important: Check that No Vermiculite Granules or Bark Chips are on the ported (holes) area around the burner.**

- o. Remove the Embaglow from the packet provided and now thin out the strands of material. Working between the logs place strands on top of the Vermiculite on the central Burner area. Placing the material between the logs will allow the flames to make the material glow.

**Note.** Ensure that no stray Embaglow material is left close to the pilot. The spark from the ignition system will track down even a single strand of Embaglow and prevent the spark from arcing to the pilot.

- p. Before sealing the glass outer door with the 2 screws and the Pozidriv screwdriver provided, check the condition of the glass and ensure it is clean and free from any finger marks. If the fire also has an outer glass door repeat the procedure.

**Note :** The Emberglow material is a consumable material and as a limited life. You can buy replacements through your local Nu-Flame Ltd Stockist or Installer.

- q. **For Synergy Perspective Glass - Wall Mounted Installations Only**

**Fitting the Glass Shelf (The Glass Shelf Will Have to be Fitted prior to Testing Commissioning & Use)**

Fit the Glass Shelf by first locating the outer 2 holes over the Rivet Stems at the left and right corners of the Case and fixing with the 2 screws provided, see diagram. The Outer Door is fitted later.

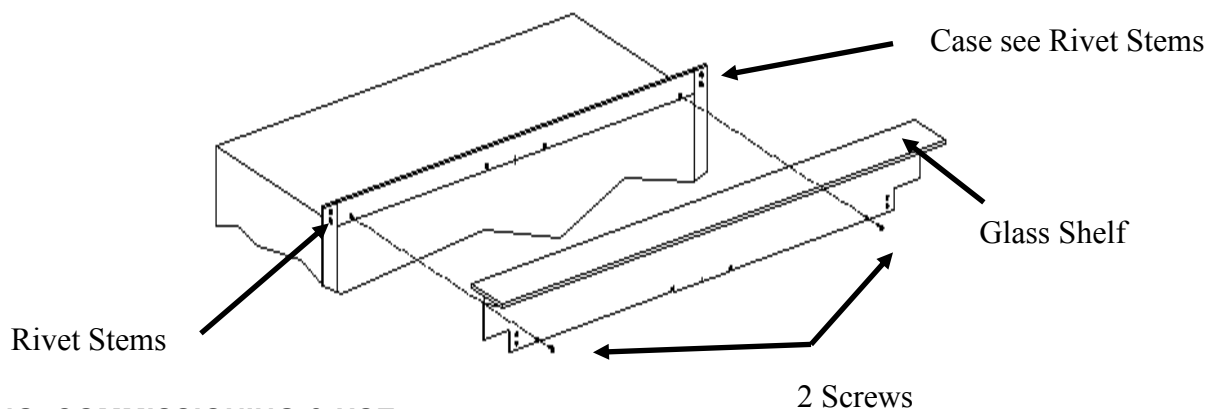

## 18. TESTING, COMMISSIONING & USE

**Important:** During its first period of use any protective coatings and oils will burn out of the fire and it is wise to ventilate the room for the first hour; also advise the customer that this may persist for the first few days until the fire is fully burnt-in.

### 18.1 - LIGHTING THE FIRE

- a. Reference to Section 2 in the Users Instructions 'Lighting & Controlling the Fire' will show how to light and operate the fire.  
b. Check that the supply pressure to the fire is at the pressures required, 20mbar (Natural Gas G20) or 37mbar (Propane G31) when set at high.

**IMPORTANT:** Ensure that the pressure test point used is sealed and gas tight.



## 18.2 - TESTING FOR SPILLAGE

- a. A restrictor is supplied with the fire for flues that have an effective height greater than 3 meters. The restrictor is fitted into the duct above the glass door with the 2 screws provided, see below.
- b. Once the fire is operational the installer must check for spillage. Carry out the lighting procedure and turn the fire to high. Allow to warm up for 5 minutes and then using a smoke match, joss stick or similar, place it centrally above the glass door as shown. The majority of the smoke must be drawn into the duct. Some small whiffs of smoke may be expelled and this is quite normal. Be careful not to introduce too much smoke (i.e. by using a pellet). A smoke match tube can be used to make holding of the match easier.  
(See drawing overleaf.)

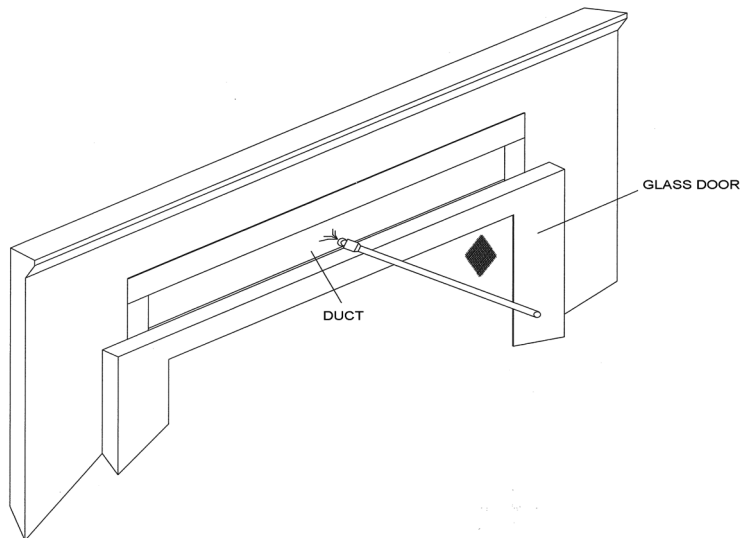

- c. Repeat the test with doors and windows to the premises/room both open and closed, and with any extractor fans in the same room or adjacent rooms running at high. The fire should continue to clear its combustion products. Also operate any other flued appliance in the same or neighbouring rooms and ensure they continue to function satisfactorily as multiple flues can work against one another.
- d. If spillage is detected during this procedure, remove the restrictor if fitted and repeat the tests.
- e. If spillage is detected and no restrictor is fitted, let the fire operate for a further 10 minutes and re-check.
- f. If the fire continues to spill, it could indicate a faulty flue or lack of ventilation. If the problem cannot be rectified immediately, disconnect the fire, affix a label and advise the customer not to use it until the problem has been resolved.
- g. **It is an offence to use or allow the use of a dangerous appliance.**

## 18.3 - FITTING THE OUTER DOOR OPTIONS

Different Trims and Outer Doors are Provided please refer to the Appropriate Heading for the Trim Ordered.

**Option - Synergy Ellesse CF with Steel or Glass Door (see photographs below and on next page)**

- a. Fit the décor panel above the glass door onto the magnets as shown.



- b. Fit the outer door (Steel or Glass) with the 2 hinge pins provided to the right hand side, the door should then be closed and held shut by the magnetic catches.

**Important: With the Glass Door version take great care when fitting the door as it is quite heavy and cumbersome.**



**Option - Synergy Ellesse CF with Echo Trim Version with Metal or Glass Door (see photograph below)**

- a. Re-fit the Outer Trim with the 4 screws.
- b. Fit the outer door (Steel or Glass) with the 2 hinge pins provided to the right hand side.
- i) The Upper Hinge Pin is fitted upward, and lower one fitted downward.
  - ii) Now secure the upper Hinge Pin with the fixing screw provided as shown, the door should then be closed and held shut by the magnet catches.

**Very Important: The Hinge Pin Screw Must be fitted to ensure the upper hinge pin does not fall out.**

**Important: With the Glass Door version take great care when fitting the door as it is quite heavy and cumbersome.**



**18.4 - FIREGUARDS**

A fireguard is not supplied with the appliance however it is **recommended** that a fireguard is fitted if the fire is to be used in the presence of **young children, the elderly, the infirm and pets.**

**! VERY IMPORTANT !**

**THE INNER GLASS PANEL AND ALSO FOR MODELS FITTED WITH AN OUTER GLASS DOOR THEY WILL BECOME VERY HOT DURING OPERATION SO WE WOULD STRESS THE USE OF A FIREGUARD IN SITUATIONS AS DETAILED ABOVE.**

## 19 - BRIEFING THE CUSTOMER

- a. The installer should brief the customer on the Operation of the Control System and all aspects of the User Instructions.
- b. The instructions/with the door release tool should be handed to the customer for their safe keeping and future servicing.
- c. Show the customer how to open the outer door by pulling at the centre of the left hand side.
- d. Show the customer how the firebox glass door can be opened for cleaning with the Pozidriv screwdriver provided. Stress that the fire must not be operated with the firebox glass door open.
- e. Explain and demonstrate to the customer that the batteries in the receiver and hand set should be replaced annually as the fire may stop working.
- f. The customer should be briefed on the need for regular servicing; this will normally be once a year.
- g. Advise the customer that, apart from batteries, there are no user replaceable parts in the fire but for servicing and spares to contact the local Nu-Flame Stockist.
- h. Advise the customer that under no circumstances must the fire be used if the firebox glass door of the fire is in any way chipped, cracked or damaged.
- j. Advise the Customer that the **Glass Panels** on the fire will become **Very Hot** during operation and that we recommend that a **Fireguard** is fitted if the fire is to be used in the presence of **Young Children, the Elderly, the Infirm and Pets**.
- i. Advise the Customer that with the Thermostatic Thermotronic System if Programmes are added to operate the fire when they are not present no soft furnishing must be close to the fire and they must take account of 'j' above.
- j. Ensure the Customer understands that the Automatic Modes will only function with the fire either on or in the standby setting and with the Handset Screen showing either TEMP or TIME, which ever is required and has been programmed.
- k. If the Handset is set at Man or the fire is turned Off the Programs will not operate the fire.
- l. Advise that the Embaglow material on the fuel bed is a consumable product and will need replacing.

**ABOUT THE FLAME PICTURE: THE SYNERGY RANGE HAVE A UNIQUE BURNER SYSTEM WHERE THE FLAME SIZES AND COLOURS WILL CHANGE LIKE A REAL FIRE AND WILL VARY FROM FIRE TO FIRE.**

### IMPORTANT WARNINGS

**THE THERMOSTATIC THERMOTRONIC CONTROL SYSTEM PROVIDES THE MEANS FOR UNATTENDED OPERATION IF THE FIRE PROGRAMS OR THERMOSTATE SETTINGS ARE USED AND THIS COULD POSE A DANGER IF COMBUSTIBLE MATERIALS ARE TOO CLOSE TO THE FIRE OR IF YOUNG CHILDREN, THE ELDERLY, INFIRM OR PETS ARE LEFT UNATTENDED. THE GLASS PANEL ON THIS FIRE WILL BECOME VERY HOT DURING OPERATION. IT IS PERFECTLY NORMAL FOR THE FIRE TO MAKE POPPING & BURBLING NOISES WHEN LIT.**

## 20 - SERVICING

### 20.1 - GENERAL

**Note: Servicing must be carried out by a registered installer.**

- a. The fire does not have to be removed for Servicing.
- b. Check the operation and ignition of the fire before servicing.
- c. Ensure the fire is cold before proceeding.
- d. Lay a dust sheet on the floor before proceeding.
- e. Carry out a gas soundness test before servicing.
- f. Open the outer door and turn off the gas supply to the fire at the isolation/pressure test elbow.
- g. If any parts need replacement, use only genuine parts supplied by Nu-Flame Ltd. Some components may look similar to those used in other gas fire, but these are not necessarily the same due to performance variations and must not be used.  
**This applies particularly to the ODS Pilot System, Gas Control and Log Set.**
- h. Disconnect the gas pipe to the control, before proceeding.

### 20.2 – ANNUAL SERVICING

**Carry out the operations in 20.1 General before proceeding**

- a. Open the Outer Door and using the Pozidriv screwdriver tool provided open the glass door and check the glass panel for any damage, it must be replaced if there are any chips, cracks or any damage before the fire can be used.
  - b. Referring to the Section 17, 'Arranging the Fuel Arrangement' and working in reverse order, collect the Embaglow (wire wool material) off the burner area, remove the bark chips, vermiculite and logs.
  - c. Remove the fuel tray.
  - d. In the base of the fire pull the electronics box and infrared sensor off their Velcro mounting.
  - e. Remove the 4 screws securing the burner mounting plate assembly; then lifting at the rear, swing the whole assembly out and clear of the fire. Take care not to mark the liners in the fire.  
This will now allow access to all gas carrying parts for maintenance checks, fault finding and or replacement.
  - f. Brush clean the burner of any vermiculite.
  - g. Brush clear the pilot area of any vermiculite; check that the aeration hole in the pilot is clear of dust removing the 2 screws securing the pilot shield if necessary for easier access.
  - h. Check and remove any debris; (by working through the hole left by the burner mounting plate) remove the 4 screws securing the debris plate at the back of the fire.
  - i. Refit in reverse order; brushing the logs clean of any soot, checking gas soundness, ignition and spillage as detailed in the relevant sections.
- Note. Ensure that no stray strands of the Embaglow material is left close to the pilot. The spark from the ignition system will track down even a single strand of Embaglow and prevent the spark from arcing to the pilot.**
- j. Check the Condition of the Glass Panel and Door Seal and replace before further use if damaged.
  - k. Clean the outer glass panel before sealing the door.
  - l. Replace the batteries in both the handset and receiver see Section 3.4. and check the operation of the Control.

**ALWAYS CONDUCT A GAS SOUNDNESS AND SPILLAGE CHECK AFTER SERVICING.**

**ALWAYS RESEAL THE PRESSURE TEST POINT AND CHECK THAT IT IS GAS TIGHT.** (This accounts for a lot of recalls.)

**ALWAYS CHECK THAT THE GLASS IS CLEAN AND FREE FROM FINGERPRINTS.** (This accounts for a lot of recalls.)

## 21 - FAULT FINDING GUIDE, SYMPTOMS AND POSSIBLE CAUSES

**Important :** In instances where it is indicating that the main control system needs changing, (specifically either of the Thermatronic Control Systems), you should investigate returning the whole Burner Control Assembly to Nu-Flame for rectification as this could be the least cost option.

- a. Prior to any Servicing ensure that you have carried out the procedures in Section 20.1 General (Servicing).
- b. Check the supply pressure at the isolation elbow.
- c. **Important :** With either of the Thermatronic Systems always change the batteries before carrying out any Fault Finding.
- d. Check the supply pressure at the isolation elbow.

### 21.1 - RESETTING THE ELECTRONIC CONTROL (Applies to Thermatronic RF System Only)

**Full Reset** - If a new handset is obtained the control system will need to learn the handset's unique code via a Full Reset.

Also, if the fire is not working and the Basic Reset (described on page 7) has not worked a Full Reset can be carried out as follows:

- a. Open the outer door by pulling at the left side to release it from the magnetic catches and open the outer door, locate the electronic Receiver Box.
- b. Locate the Reset Hole on the side of the Receiver and using a pen press and hold in the Reset button until you hear two beeps.
- c. The first beep is short and the second beep is long. After the second beep release the Reset Button.
- d. Now on the Handset, within the next 20 seconds press and hold the Small Flame Button until you hear two additional short beeps confirming the code is set in the Receiver.
- e. If you hear one long beep the Code as not been set so repeat the procedure.
- f. If the Handset still does not work check the wiring and or replace the Receiver and Handset .

### 21.2 - NO SPARK IGNITION

- a. Replace the batteries in the receiver and handset see Section 3.4 and check the Control.
- b. Check there is no vermiculite shorting out the electrode or blocking gas from the pilot.
- c. Check that no stray Embaglow material is near the pilot as the spark will track down a single strand of Embaglow and prevent the spark arcing to the pilot.
- d. Check the condition of the Ignition lead and ensure it is connected to both the ignition electrode and receiver. Replace if required.
- e. Check that gas is flowing from the pilot during the ignition sequence. Clean or Replace as required.
- f. Listen to the control to hear if the pilot gas solenoid is opening.
- g. Change the receiver and the handset at the same time and/or gas control. Refer to Diagram for Cable connections in section 22.

**Important :** In instances where it is indicating that either of the main control systems need changing, you should investigate returning the whole Burner Control Assembly to Nu-Flame for rectification as this could be the least cost option.

### 21.3 - PILOT GOES OUT AFTER FIRST LIGHTING

- a. Check there is no vermiculite blocking the flame to the thermocouple.
- b. Check the thermocouple is tightly connected to the control.
- c. Change the pilot assembly as a new thermocouple may be required.
- d. Change the receiver and the handset at the same time and/or the gas control. Refer to Diagram for Cable connections on in section 22.
- e. Also see Section 21.2 & 21.4

### 21.4 - PILOT LIGHTS BUT MAIN BURNER DOES NOT LIGHT

- a. Check there is no vermiculite blocking the flame from the pilot to the main burner.
- b. Check if the main control knob on the control is turning to the high setting and listen to hear if the solenoid valve is opening. Change the receiver, infrared sensor and the handset at the same time and/or the gas control. Refer to Diagram for Cable connections in Section 31. Check c. (below) before replacing any parts.
- c. Check if the main injector is blocked. Clean or Replace.
- d. Both of the Thermatronic Controls have a pressure point to allow the Burner Pressure to be checked.

It is at the left side of the Control and is the rear Pressure Test Point. Ensure the Screw is gas tight after the test.

**Important :** In instances where it is indicating that either of the main control systems need changing, you should investigate returning the whole Burner Control Assembly to Nu-Flame for rectification as this could be the least cost option.

### 21.5 - PILOT FLAME SHORTENS, OR GOES OUT WHEN MAIN BURNER IS SELECTED

- a. Monitor the supply pressure at the isolation elbow as the main burner lights. If pressure drops, check gas pipe sizing, quality of pipe bending. Check for debris in the gas supply and or gas filter if fitted.
- b. Check that another appliance is not affecting the gas supply pressure.

### 21.6 - POOR FLAME PICTURE

- a. Check the supply pressure is correct at the isolation elbow. If the pressure is low, check gas pipe sizing, quality of pipe bending. Check for debris in the gas supply and or gas filter if fitted.
- b. Both of the Thermatronic Controls have a pressure point to allow the Burner Pressure to be checked. It is at the left side of the Control and is the rear Pressure Test Point. Ensure the Screw is gas tight after the test.
- c. Check that another appliance is not affecting the gas supply pressure.
- d. Check there is not a flue/ventilation problem – carry out a spillage test.
- f. Check fuel bed layout as detailed in Section 17.

**ABOUT THE FLAME PICTURE: THE SYNERGY RANGE HAS A UNIQUE BURNER SYSTEM WHERE THE FLAME SIZES AND COLOURS WILL CHANGE LIKE A REAL FIRE AND WILL VARY FROM FIRE TO FIRE.**

**IT IS PERFECTLY NORMAL FOR THE FIRE TO MAKE POPPING & BURBLING NOISES WHEN LIT.**

### **21.7 - THERMOSTATIC THERMOTRONIC HANDSET NOT WORKING**

- a. Check the handset as been programmed correctly as detailed in Section 3.5 and works correctly.
- b. Ensure the Customer understands that the Fire must be either on or set at Standby (pilot lit) and the Handset Screen set at either TEMP or TIMER to enable the Programs to function.
- c. Check that all other functions on Handset work.
- d. Change the Handset and or Receiver and or Burner Control System.

**Important** : In instances where it is indicating that either of the main control systems need changing, you should investigate returning the whole Burner Control Assembly to Nu-Flame for rectification as this could be the least cost option.

**ALWAYS CONDUCT A GAS SOUNDNESS AND SPILLAGE CHECK AFTER SERVICING.**

**ALWAYS RESEAL THE PRESSURE TEST POINT AND CHECK THAT IT IS GAS TIGHT.** (This accounts for a lot of recalls.)

**ALWAYS CHECK THAT THE GLASS IS CLEAN AND FREE FROM FINGERPRINTS.** (This accounts for a lot of recalls.)

## 22 - ENERGY CLASS & PRODUCT FICHE (Natural Gas Models)

### SYNERGY ELLESSE CF (Natural Gas ) Standard Remote Control

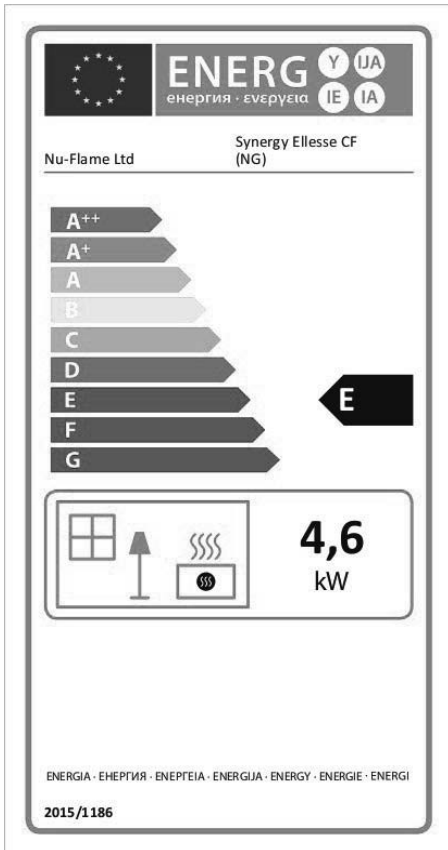

Supplier	Nu-Flame Limited
Model	Synergy Ellesse CF (NG)
Energy Efficiency Class	E
Direct Heat Output	4.6kW
Energy Efficiency Index	69.0
Useful Energy Efficiency at Maximum	80.0%
Useful Energy Efficiency at Minimum	76.0%

The fire must be Installed & serviced by a properly qualified (in accordance with Local & National Codes) Installation Engineer and in accordance with these Installation Instructions

### SYNERGY ELESSE CF (Natural Gas ) Thermostatic Remote Control

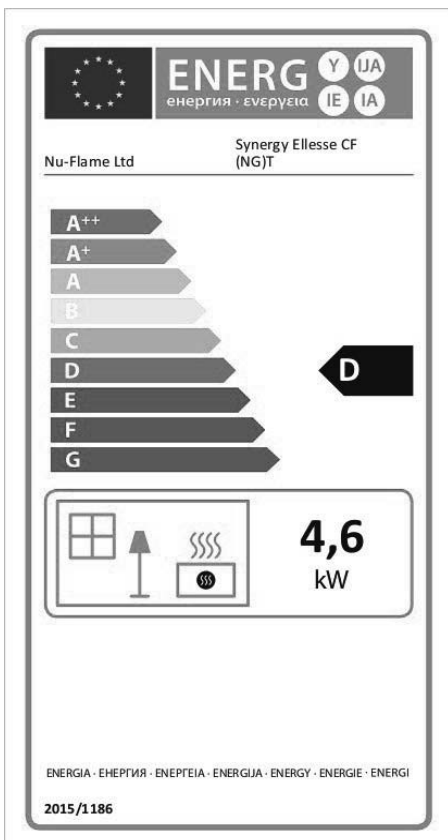

Supplier	Nu-Flame Limited
Model	Synergy Ellesse CF (NG) T
Energy Efficiency Class	D
Direct Heat Output	4.6kW
Energy Efficiency Index	74.0
Useful Energy Efficiency at Maximum	80.0%
Useful Energy Efficiency at Minimum	76.0%

The fire must be Installed & serviced by a properly qualified (in accordance with Local & National Codes) Installation Engineer and in accordance with these Installation Instructions

## 22 - ENERGY CLASS & PRODUCT FICHE (Propane Models)

### SYNERGY ELLESSE CF (Propane) Standard Remote Control

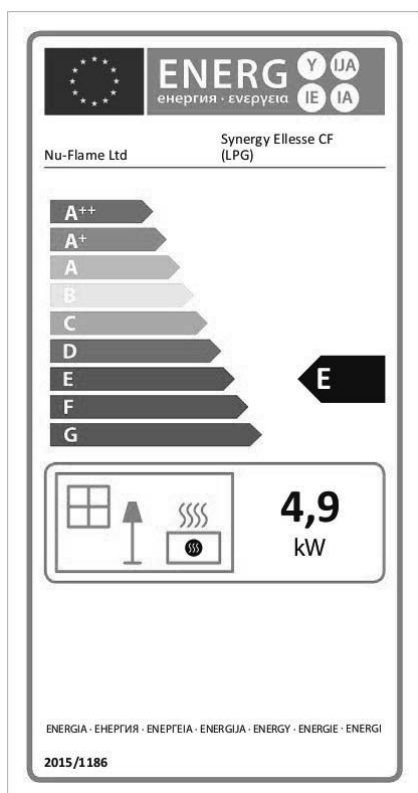

Supplier	Nu-Flame Limited
Model	Synergy Ellesse CF (LPG)
Energy Efficiency Class	E
Direct Heat Output	4.9kW
Energy Efficiency Index	68.7
Useful Energy Efficiency at Maximum	79.7%
Useful Energy Efficiency at Minimum	73.1%
<p>The fire must be Installed &amp; serviced by a properly qualified (in accordance with Local &amp; National Codes) Installation Engineer and in accordance with these Installation Instructions</p>	

### SYNERGY ELLESSE CF (Propane) Thermostatic Remote Control

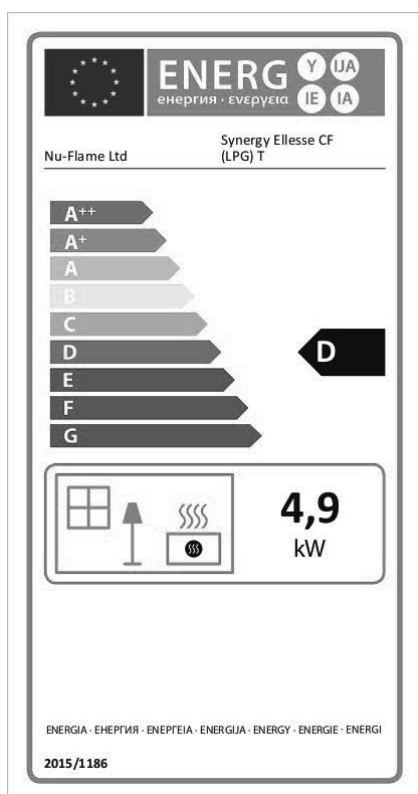

Supplier	Nu-Flame Limited
Model	Synergy Ellesse CF (LPG) T
Energy Efficiency Class	D
Direct Heat Output	4.9kW
Energy Efficiency Index	73.7
Useful Energy Efficiency at Maximum	79.7%
Useful Energy Efficiency at Minimum	73.1%
<p>The fire must be Installed &amp; serviced by a properly qualified (in accordance with Local &amp; National Codes) Installation Engineer and in accordance with these Installation Instructions</p>	



## EU Declaration of Conformity

**Name of the Client** : Nu-Flame Ltd  
Address of the Client : Unit 4  
: Kimpton Trade & Business Centre  
: Minden Road  
: Sutton  
: Surrey  
: SM3 9PF

Telephone : 020 8641 9992

Manufacturing Location : As above

**This declaration of conformity is issued under the sole responsibility of the manufacturer above for:**

Product : Synergy Ellesse CF

Certificate Number : CE688450

**The object of the declaration described above is in conformity with relevant harmonized legislation**

Gas Appliance Regulation (EU) 2016/426

The following harmonised standards and technical specification have been applied:

BS 7977-1: 2009 + A1: 2013 Specification for safety and rational use of energy of domestic gas appliances – Part 1: Radiant/convectors

**Where the Essential Requirements of the GAR have been met and approved by Notified Body:**

Responsible Test House : BSI Group  
Address : Holywell Park  
: Ashby Road  
: Loughborough  
: LE11 3AQ  
: United Kingdom

Authorized Signature of Manufacturer:



Date of Issue: 21<sup>st</sup> April 2018

### 23. DIAGRAM OF INFRARED CONTROL SYSTEM

**MERTIK MAXITROL**

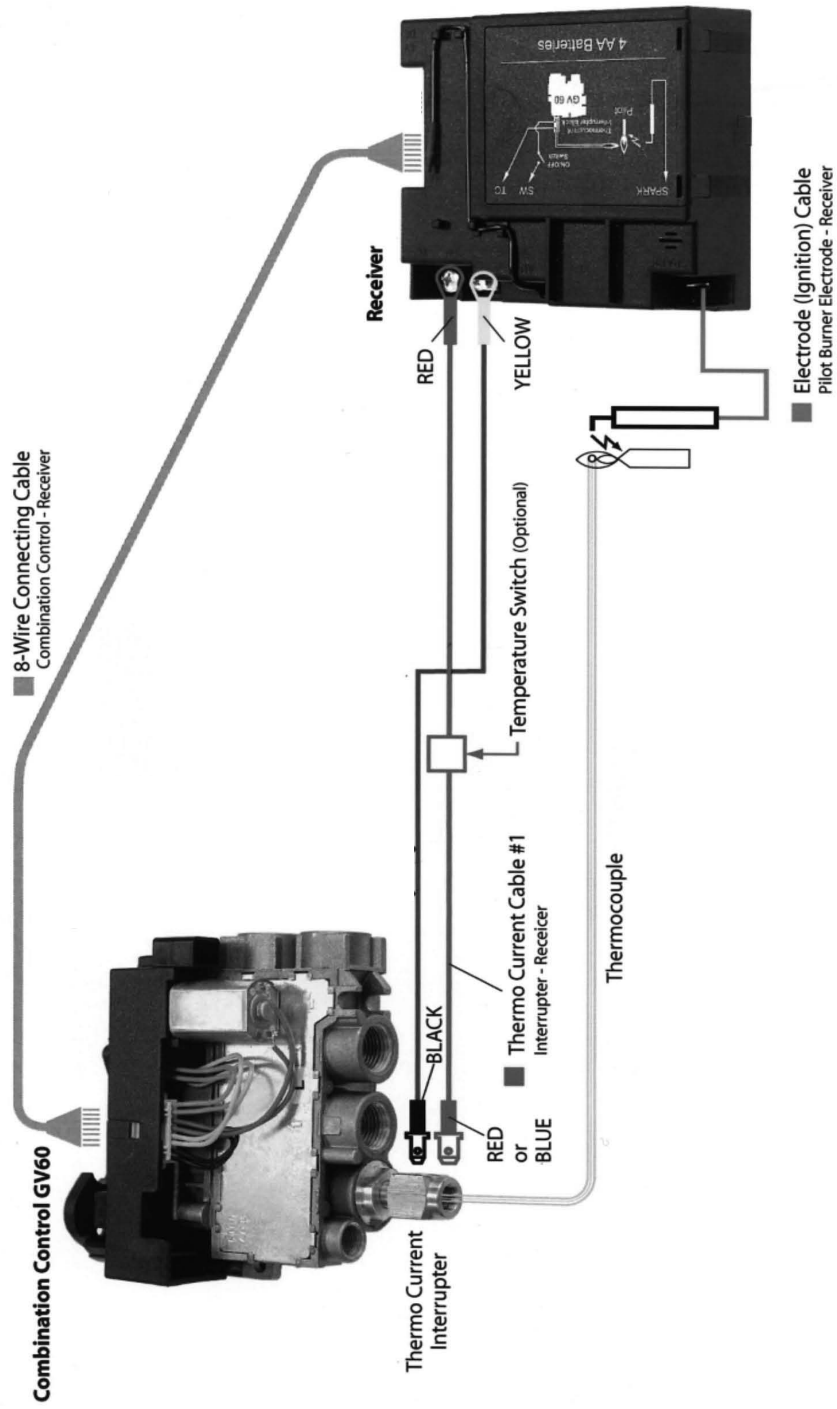



**Telephone 020 8254 6802**

**Nu-Flame Warranty and Repair Procedure for The Synergy Ellesse CF.**

The Nu-Flame Synergy Ellesse CF is guaranteed for 1 year from the date of purchase. During that time our guarantee is to send replacement parts for a fire that proves to have faulty components or workmanship. At our option we may decide to repair, or replace, at no charge a fire that proves to have faulty components or workmanship.

**Telephone Help Line.** In the event of a problem with a fire the first course of action should be to telephone our technical department on 020 8254 6802 during normal working hours 9 - 5.30 Monday - Friday (closed 1 - 1.30). If possible this should be done before the installer leaves site as we may well be able to resolve the problem over the phone, and, in any event it will save the installer a return visit to site. If we are not able to resolve the problem over the phone we will decide the most expedient way of resolving the problem and this is likely to be to send replacement parts. It is possible that we will ask you to return the fire or parts of the fire and if this is the case we will log your details and give you a return reference number.

**Returning the Fire and parts thereof.** After assessment we might consider it best to return part of the appliance, such as the burner only, for testing. In this example the burner can then be thoroughly inspected and any signs of installation faults can be reported back to you. After any repair work is carried out the flow rates can be checked and re-set if necessary in order to fully comply with CE approval. **Note:** It is a condition of the warranty that you do not return any parts to us unless we request you to do so. For example if we request that the burner only is returned and you send the entire appliance, the fuel bed and other items could be damaged or lost during the return delivery to us. We will not be liable for any such breakages, or losses

Under no circumstances should any attempt be made to repair the burner on site without our express knowledge and approval during the warranty period.

This guarantee is given subject to the following provisions:

1. That the installation is carried out by a GAS SAFE registered installer (we may require their registration details).
2. That the appliance is installed and used in accordance with our Installation & User instructions.
3. That the gas supply pressure at the appliance is not more than 3mbar below the gas pressure stated on the data plate when the appliance is running on high flame, with any other major gas appliances also running.
4. That the fireplace and flue system conform to relevant local codes, building regulations and British Standards.
5. This Guarantee is not transferable and relates to the original installation only.
6. The appliance has not been subject to misuse or accident or been modified or repaired by any person other than the authorised employee or authorised representative of Nu-Flame Ltd.
7. The Record Data section on the front of the Installation & Servicing Instructions is to be completed on installation.
8. Nu-Flame Ltd accepts no liability for any consequential loss or damage arising from the use or failure of the product or any information provided, including, but not limited to, economic or financial loss, damage to peripheral equipment or products, loss of use, productivity or time.
9. That the serial no. data plate on the burner is intact.

This guarantee in no way reduces your statutory rights.

This guarantee supersedes any previously published guarantees.

**Chargeable Repairs During And After The Warranty Period**

If a repair is chargeable during the warranty period, due to installation faults we will inform you and where possible give you a quote, or if this is not possible, a price guide before starting work. We cannot always give a firm cost until we commence the repair as it is not always possible to tell which components have been damaged.