

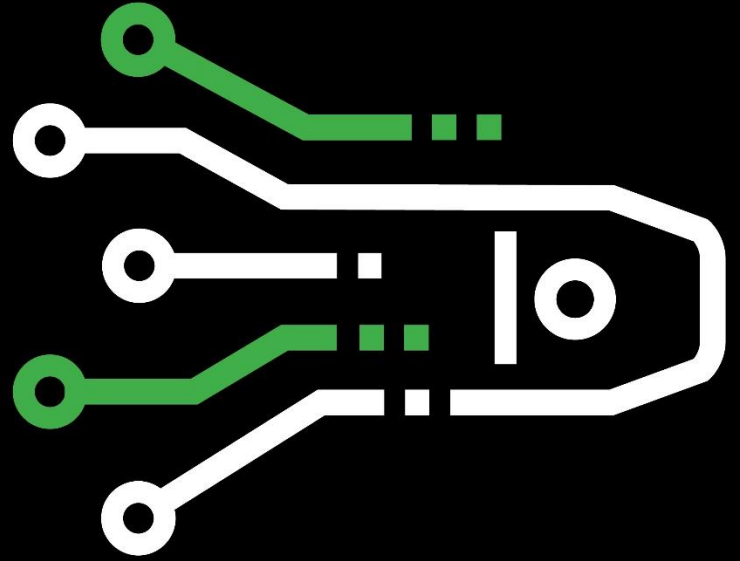

RAW DATA. REFINED RESULTS.

OPERATIONS MANUAL



SENSORS

ST350 - STRAIN TRANSDUCER

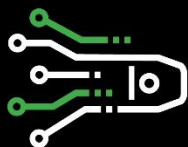

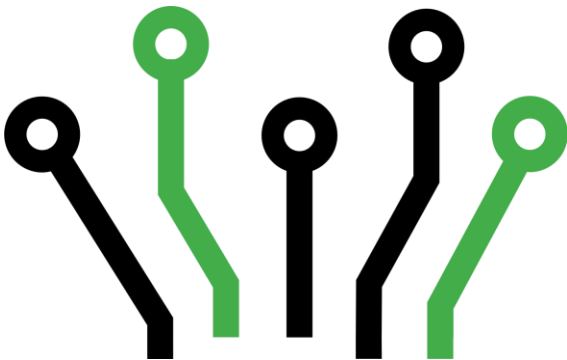

Document Revision History

Version	Date	Changes
1.0	5/15/2012	Initial release document
2.0	6/7/2012	<ul style="list-style-type: none"> ▪ Updated to reflect the change in hardware ▪ Document formatting updated
2.1	1/2/2013	Interim version-minor changes to formatting
2.2	4/2/2013	<ul style="list-style-type: none"> ▪ Updated to reflect the recent CE compliance approval ▪ Power ratings updated
3.0	7/20/18	<ul style="list-style-type: none"> ▪ Updated to include new corrosion protection ▪ Minor changes to specifications ▪ New template and styles were applied

No part of this operations manual may be reproduced, by any means, without the written consent of BDI.

The information contained within this manual is believed to be accurate and reliable. However, BDI assumes no responsibility for errors, omissions or misinterpretations. The information herein is subject to change without notification.

Copyright © 1989 – 2018
 Bridge Diagnostics, Inc. (dba BDI)



WARRANTY INFORMATION

BDI warrants its products to be free from defects in materials and workmanship under normal use and service for thirty-six (36) months from date of shipment. This warranty shall be void if any products have been subjected to modification, misuse, neglect, accidents of nature, or shipping damage. Batteries have no warranty.

All equipment manufactured by BDI is intended for use by a qualified professional only. Under this warranty BDI's obligation is limited to repairing or replacing (at BDI's option) of defective products. In no event shall BDI be liable for punitive, exemplary, special, indirect, incidental, or consequential damages and the customer shall assume all costs of removing, reinstalling, and shipping of defective products. EXCEPT AS STATED HEREIN, BDI MAKES NO WARRANTIES, EXPRESSED OR IMPLIED, AND SPECIFICALLY DISCLAIMS ANY IMPLIED WARRANTY OF FITNESS FOR A PARTICULAR PURPOSE OR MERCHANTABILITY.

Before returning any product, BDI technical support must be contacted at +1-303-494-3230 or by visiting BDITEST.COM/contact and submitting a request. A technician will help determine the nature of the problem and if it cannot be resolved, authorization will be given to return the item. A return merchandise authorization (RMA) will be sent to the customer to be filled out and shipped back with the equipment. BDI will not accept shipment of any product without prior authorization as provided herein.

Ship all equipment to:

BDI

ATTN: TECHNICAL SUPPORT

740 S PIERCE AVE UNIT 15

LOUISVILLE CO 80027

+1.303.494.3230

TABLE OF CONTENTS

- 1. Introduction7
 - 1.1 About the ST350 Strain Transducer7
 - 1.2 About this manual.....7
- 2. ST350 Overview.....8
 - 2.1 Technical Specifications8
 - 2.2 Options and Accessories9
 - 2.3 Applications10
- 3. Operation.....10
 - 3.1 Theory of Operation10
 - 3.2 Potential Strain Measurement Issues11
 - 3.2.1 Temperature Variation.....11
 - 3.2.2 Instrumentation Cable Issues12
 - 3.3 Connecting to Data Acquisition Systems12
 - 3.3.1 Excitation Voltage12
 - 3.3.2 Electrical Connections.....12
 - 3.3.3 Applying Calibration Factors13
 - 3.4 Verifying ST350 Output13
 - 3.4.1 Resistance Test13
 - 3.4.2 Resolution/Noise Test.....14
 - 3.4.3 Sensor Response Test14
 - 3.4.4 Field Adjusting Excessive Offsets.....15
 - 3.5 Verifying Accuracy15
 - 3.5.1 Factory Calibration15
 - 3.5.2 Items for Consideration for User Verification Tests.....15
- 4. Installation.....17
 - 4.1 General Installation Guide.....17
 - 4.1.1 Prepare Mounting Area17
 - 4.1.2 Installation.....18
 - 4.2 Installation on Steel Members.....19
 - 4.1 Installation on Concrete Members23
 - 4.1.1 Concrete Mounting Studs23
 - 4.1.2 Attaching ST350 with Extension to R/C Members.....24
 - 4.1.3 Attaching Extension to the ST350.....25
 - 4.2 Installation on Other Surfaces.....29
 - 4.2.1 Timber Members.....29
 - 4.2.2 Composite Materials29
- 5. Maintenance & Recalibration29
 - 5.1 Maintenance Considerations29
 - 5.2 Recalibration29

LIST OF TABLES

Table 1: ST350 Specifications	8
Table 2: ST350 Options and Accessories	9
Table 3: Typical Applications for ST350 strain transducers	10
Table 4: ST350 Wiring Designations & Intelliducer Pinout	12
Table 5: ST350 Extension Limits.....	24
Table 6: Gage Extension Factors	24
Table 7: Maximum Strain Ranges	25

LIST OF FIGURES

Figure 1: ST350 Drawing (inches)	8
Figure 2: ST350 Schematic.....	11
Figure 3: Noise levels of the ST350 on a 24-bit data acquisition system	14
Figure 4: Typical Smooth Output Response and Zero Offset	14
Figure 5: Alignment Marking for ST350 Installation	18
Figure 6: Mounting Position & Surface Preparation Marks.....	18
Figure 7: Typical ST350 Installation.....	19
Figure 8: Identifying Metric vs. Imperial Tabs.....	19
Figure 9: Mounting Tabs on the ST350 using the Tab Jig.....	20
Figure 10: Marking ST350 Center Mounting Location.....	20
Figure 11: Tab Removal Tool (TRT).....	21
Figure 12: TRT with a Tab Inserted	22
Figure 13: Removing a Tab with the TRT.....	22
Figure 14: ST350 Concrete Drilling Jig.....	23
Figure 15: ST350 Extension Mounting Jig	26
Figure 16: ST350 Extension Mounting Diagram	26
Figure 17: Aligning ST350 and Extension in the Jig	27
Figure 18: Extension Alignment Tab	27
Figure 19: Attaching Tab to Extension.....	27
Figure 20: ST350 With Extensions Attached to an R/C Structure	28

1. INTRODUCTION

1.1 ABOUT THE ST350 STRAIN TRANSDUCER

The ST350 strain transducers have been designed for recording dynamic and other induced strains on all types of structural members and to be compatible with most data acquisition systems. While mostly used in rugged field applications, they are also suitable for many laboratory and manufacturing scenarios. The ST350 internal circuitry consists of a full Wheatstone Bridge with four fully-active 350Ω foil gages optimized to provide a high electrical output for a given strain magnitude. Each transducer is individually calibrated with a highly-accurate, N.I.S.T.-traceable calibration system.

Each unit is fully sealed, designed to exceed the IP67 rating, and equipped with two pre-drilled mounting holes to keep the gage lengths consistent for all installations. Based on the structure's material and length of time the ST350 is to be installed, various mounting techniques can be used including adhesives, welding, expandable anchors, and screws.

1.2 ABOUT THIS MANUAL

This is a comprehensive document that explains the functions and features of the ST350. BDI also manufactures two types of data acquisition systems, which will be referenced throughout the manual.

1. **Structural Testing System (STS):** Rugged, wireless, battery powered DAQ that includes an intelligent (Intelliducer) connector design, which makes the system extremely easy to deploy on a variety of field projects.
2. **Structural Monitoring System (SMS):** Modular system with 4- or 16-channel nodes that can be used in laboratories or on permanent large scales monitoring projects.

The following highlighted message blocks will periodically appear and contain important information that the user should be aware of.



STOP: This symbol and corresponding message represents information regarding the device that if not followed could lead to damaging the device! Pay close attention to this message.



WARNING: This symbol and corresponding message represents vital information and is critical for the device operation and/or the operational settings/configuration.



INFORMATION: This symbol and corresponding message represents general information and/or tips on successfully operating/configuring the device.

2. ST350 OVERVIEW

2.1 TECHNICAL SPECIFICATIONS

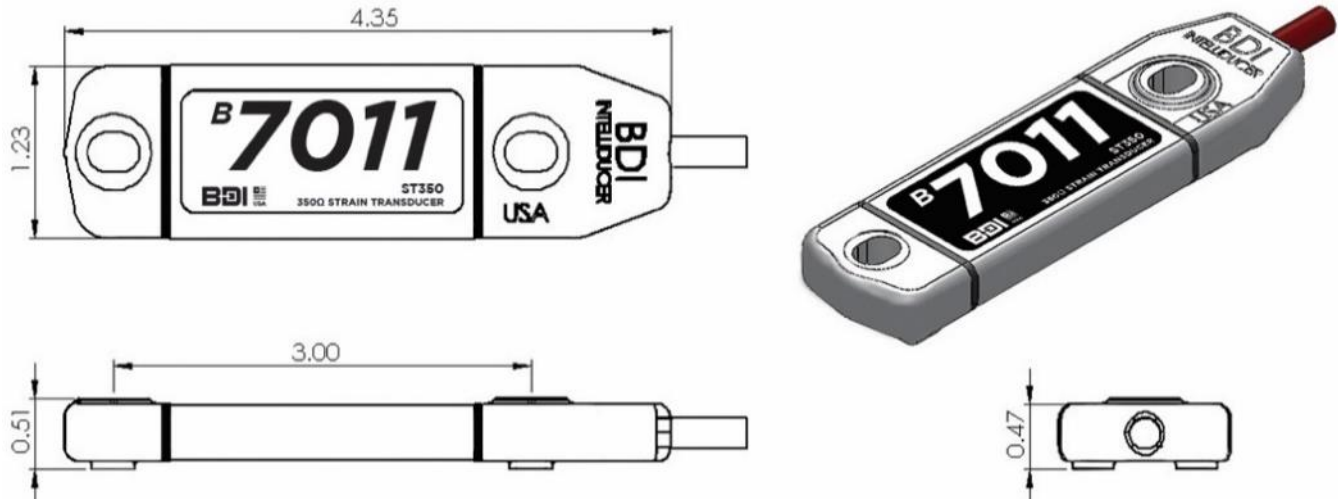

Figure 1: ST350 Drawing (inches)

Table 1: ST350 Specifications

MODEL	ST350
TYPE	350Ω
CIRCUIT	Full Wheatstone bridge with 4 active 350Ω strain gages
EXCITATION VOLTAGE	+1.0 to +10.0 Vdc
OUTPUT	mV level, ratiometric to Excitation Voltage
OFFSET	< 1.5 mV at time and temperature of calibration
POWER RATING: MAX TYPICAL INTELLIDUCER¹	300 mW 72 mW @ +5.0 Vdc 13 mW @ +5.0 Vdc
STRAIN RANGE	±4,000 $\mu\epsilon$ (Calibrated to ±2,000 $\mu\epsilon$)
FORCE REQUIRED FOR 1,000$\mu\epsilon$	~17 lb (~76N)
TYPICAL SENSITIVITY	~500 $\mu\epsilon$ /mVout/Vin
ACCURACY²	< ±1%
CALIBRATION	Individually calibrated using N.I.S.T.-traceable automated system. Calibration curve & factor provided
THERMISTOR (OPTIONAL)	3 kΩ - NTC
EFFECTIVE GAGE LENGTH	3.0 in (76.2 mm) [Gage Extensions available for R/C structures]
CABLE	Custom lead cable length made to order: IC-02-187 [22 AWG, 2 shielded pair, drain wire, red PVC jacket] IC-02-250 [22 AWG, 2 shielded pair, drain wire, blue PVC jacket] IC-03-250 [24 AWG, 3 shielded pair, drain wire, black PVC jacket]
HOUSING	Machined 6061 Aluminum Alloy

CORROSION PROTECTION	Hard Anodized Clear (MIL-A-8625 Type III)
WEATHER PROTECTION	Designed to exceed IP67 Optional 100 ft (30 m), waterproofing available
TEMPERATURE RATING³	-58° to +176 °F (-50° to +80 °C)
SIZE	4.38 in x 1.25 in x 0.50 in (111 mm x 32 mm x 12.7 mm)
WEIGHT	0.19 lb (85 g)
MOUNTING HOLES	Through holes for ¼ in (M6) bolts or anchors Reusable mounting tabs (gluing/welding)

¹ Intelliducer connector required with STS Intelliducer data acquisition nodes.





² Accuracy defined at the calibrated ±2,000 µε range.

³ Temperature limit based on instrumentation cable operating temperatures, call BDI for wide temperature range cable options.

2.2 OPTIONS AND ACCESSORIES

The ST350 is supported by several available options and accessories depending on the application and use. See Table 2 for a list of options and accessories that we supply.

Table 2: ST350 Options and Accessories

OPTIONS AND ACCESSORIES	
	Intelliducer Connector – Required for use with STS data acquisition nodes, cable is connected and potted for a weatherproof seal
	Integrated Thermistor – Temperature range of -55 °C to +220 °C, ±0.5 °C accuracy
	Reusable Mounting Tabs – ¼-20 or M6, zinc plated steel mounting tab
	Tab Jig – Machined aluminum jig for safely attaching mounting tabs to the strain transducer; Includes either 7/16 in or M10 end wrench
	Gage Extension – Machined aluminum 24 in (610 mm) gage length extension with 3.0 in (76 mm) increments

	<p>Extension Jig – Aluminum mounting jig for safely accurately attaching Gage Extensions</p>
	<p>Installation Jigs – Welding or concrete drilling jigs</p>
	<p>Protective Covers – Insulated aluminum protective covers</p>

2.3 APPLICATIONS

Table 3: Typical Applications for ST350 strain transducers

<p>HIGHWAY AND RAILWAY BRIDGES</p>	<ul style="list-style-type: none"> + Static and Dynamic Live Load Testing + Moveable Bridge Operation Forces + Overload Detection
<p>RIVER CONTROL STRUCTURES</p>	<ul style="list-style-type: none"> + Navigation Lock Gate Load Responses (Lift, Miter, Radial) + Tainter Gates (Trunnion Friction) + Mechanical Drive Components (Torque, Force)
<p>CABLE FORCES</p>	<ul style="list-style-type: none"> + Individual force & group balancing – static
<p>LABORATORY TESTING</p>	<ul style="list-style-type: none"> + Classroom teaching tool + Measure responses for structural members and components + Integrate with existing A/D systems
<p>BUILDINGS</p>	<ul style="list-style-type: none"> + ASTM Standard Floor Load Tests + Construction Vibration Monitoring + Concrete Curing Temperature Tracking + Earthquake Response Monitoring

3. OPERATION

3.1 THEORY OF OPERATION

The internal components of the ST350 consist of a custom-manufactured 350-Ohm Wheatstone bridge foil transducer-class strain gage mounted inside a flexible proving ring. The four active arms are arranged inside the ring in such a manner that the total output provides approximately 3.5 times the output compared to a typical 1/4-bridge foil gage under the same induced strain level.

The ST350 produces a voltage potential across opposing Wheatstone Bridge corners (Figure 2) which varies with tension and compression. The sensitive (longitudinal) axis is parallel to the face of the serial plate on the top of the sensor housing (direction of the cable exit).

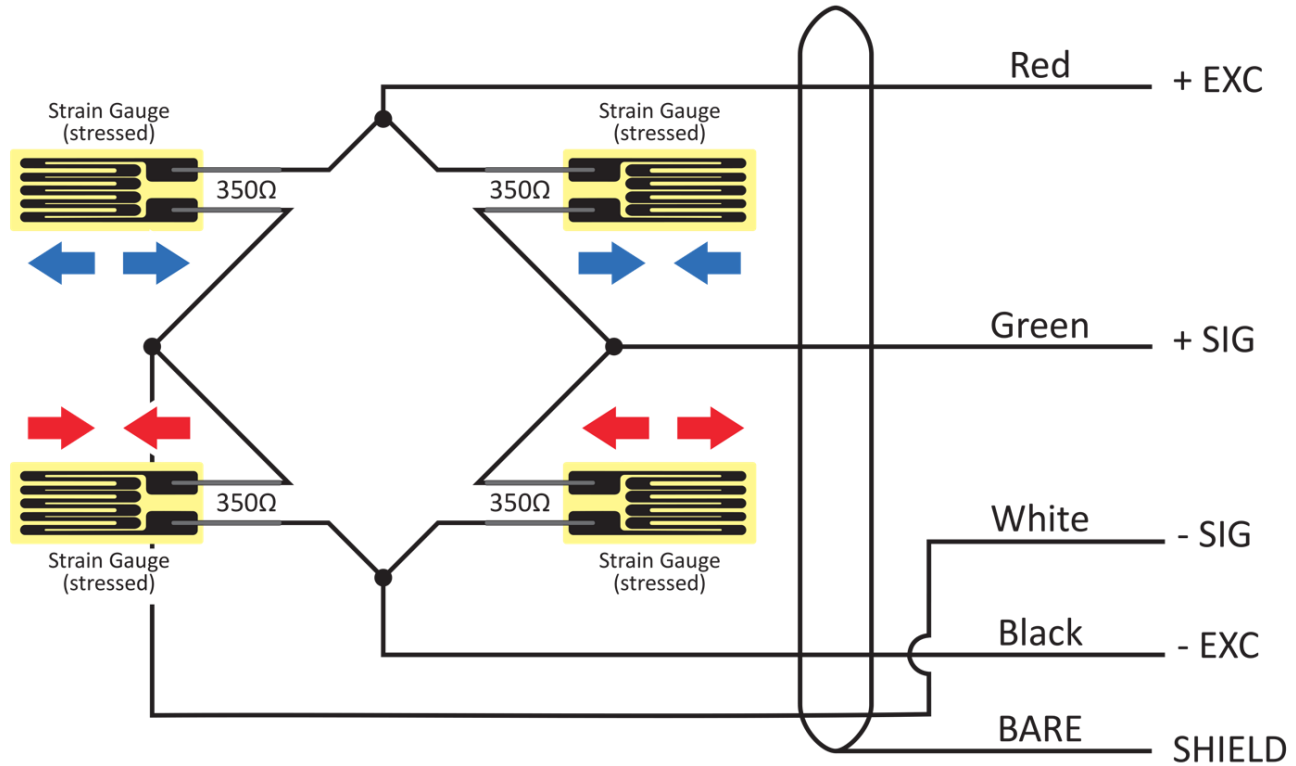

Figure 2: ST350 Schematic

STOP: It is important to note that the portion of the ST350 housing that the label is affixed to (the lid) is actually “floating” and is only held in place through the weatherproof potting material that is used. Be cautious while handling and while installing the ST350 not to put excessive pressure on the lid.

3.2 POTENTIAL STRAIN MEASUREMENT ISSUES

3.2.1 Temperature Variation

STOP: It is important to note that the ST350 was designed for short-term testing applications where changes in temperature are generally small enough to not affect the output of the strain measurement. We have not developed temperature compensation curves for the ST350 and therefore recommend that the sensors be periodically zeroed during any long-term monitoring project and the focus on of the measurement be geared toward the short-term live-load responses of the structure.

When the ST350 is attached to a structure subjected to temperature variations, the sensor is forced to undergo the same temperature-induced deformations as the structural member. In the case of an increase in ambient temperature, the member will expand. However, since the transducer ends are anchored to the structural member and the “temperature inertia” of the ST350 is much less, (heats up and cools much faster than the large member) the gage will attempt to expand between the anchored end blocks, which creates a compression (opposite of expected). The same goes for a temperature drop, which, since

the gage cools off faster than the member, will register tension. If the sensor is to be mounted on the structure for an extended period of time, it will need to have its zero-offset reset periodically as it drifts around with temperature changes.

If the ST350 is exposed to direct sunlight during live-load tests, such as on truss members or on top of a concrete slab, significant temperature drift can be experienced during short periods of time due to changing cloud cover and/or breezes. Covering the ST350 with foam and aluminum tape can usually reduce or eliminate this problem. BDI also supplied insulated aluminum covers that help reduce these effects greatly.

3.2.2 Instrumentation Cable Issues

The output responses for the ST350 will vary slightly depending on the length of the instrumentation cable due to resistance of the lead wires. To address this, ST350s are calibrated with the instrumentation cable installed, meaning that this resistance has automatically been taken into account through the calibration process. If, however, the user splices a significantly long cable to the cable that has been supplied with the unit, a small error that is approximately the ratio of the additional resistance to the gage resistance will be introduced. Therefore, BDI always recommends calibrating the transducer with the cable that is going to be used in the field.

3.3 CONNECTING TO DATA ACQUISITION SYSTEMS

This section outlines how to connect and test the ST350 for most standard data acquisition systems that are designed to handle a differential voltage output.

3.3.1 Excitation Voltage

It is recommended that the Wheatstone bridge excitation voltage be at or below +10 Vdc since higher voltages can cause drift and stability issues due to gage heating. For example, the BDI STS/SMS data acquisition systems uses a regulated +5 Vdc excitation voltage which provides excellent results. Allowing the electronics and the gages to warm up for several minutes is also recommended. A small amount of drift will be detected during the warming process, but should stabilize within several minutes.

3.3.2 Electrical Connections



INFORMATION: When using the ST350 with any STS data acquisition node, the connection has already been pre-wired to the twist-lock plug and no further action is necessary.

The ST350 uses a standard Wheatstone Bridge 4-wire hookup. [Table 4](#) outlines the wiring color/signal connections and includes the pinout for Intelliducer connectors used with the STS data acquisition nodes.

Table 4: ST350 Wiring Designations & Intelliducer Pinout

INSTRUMENTATION CABLE TYPE		SIGNAL	INTELLIDUCER PINOUT
IC-02-187 & IC-02-250	IC-03-250		
RED	RED	+ Excitation	G
BLACK	BLACK (PAIRED W/ RED)	- Excitation (GND)	K
GREEN	GREEN	+ Signal	C
WHITE	BLACK (PAIRED W/ GREEN)	- Signal	J
BARE	ALL BARE WIRES	Shield/Drain (Earth GND)	Integrated into pin K
N/A	WHITE	+ Temp	B
N/A	BLACK (PAIRED W/ WHITE)	- Temp	Integrated into pin K

3.3.3 Applying Calibration Factors

Each ST350 is supplied with a N.I.S.T.-traceable calibration factor. Since this sensor is a ratiometric sensor and can be supplied a range of excitation voltage, the supplied calibration factor is normalized for excitation voltage. To calculate the proper calibration factor for the data acquisition system, the excitation voltage that is used must be multiplied by the General Gage Factor (GGF). The following is an example of the supplied calibration factor:

$$\text{GGF} = \text{### } \mu\epsilon / \text{mV}_{\text{out}} / \text{V}_{\text{exc}}$$

Where:

GGF = General Gage Factor

= Numeric Calibration Factor

$\mu\epsilon$ = microstrain (strain x 10-6)

mV_{out} = Output Voltage in Millivolts DC

V_{exc} = Excitation Voltage supplied to sensor in Volts DC

Example of applying the GGF:

This example is using a ST350 with a supplied $\text{GGF} = 504.32 \mu\epsilon / \text{mV}_{\text{out}} / \text{V}_{\text{exc}}$. The data acquisition system supplies a +5.0 Vdc excitation and reads the output in volts so the GGF must be adjusted to $\mu\epsilon / \text{V}_{\text{out}}$ before applying the GGF in the results. The current reading on the data acquisition system is $3.2312 \times 10^{-3} \text{Vdc}$.

Step 1: Convert GGF to $\mu\epsilon / \text{mV}_{\text{out}}$

$$\text{GGF} = 504.32 \mu\epsilon / \text{mV}_{\text{out}} / \text{V}_{\text{exc}} \div 5 \text{V}_{\text{exc}} \times \frac{1000 \text{mV}_{\text{out}}}{\text{V}_{\text{out}}} = 100,864 \frac{\mu\epsilon}{\text{V}_{\text{out}}}$$

Step 2: Apply GGF to output voltage from data acquisition system

$$\text{Reading} = \text{V}_{\text{out}} \times \text{GGF} = 3.2312 \times 10^{-3} \text{V}_{\text{out}} \times 100,864 \frac{\mu\epsilon}{\text{V}_{\text{out}}}$$

$$\text{Reading} = 325.9 \mu\epsilon$$



STOP: Insure that the measured output is in terms of millivolts (mV), or the calculated strain values can be off by orders of magnitudes.

3.4 VERIFYING ST350 OUTPUT

It is important to periodically verify the integrity and output of each ST350. Below is a list of tests that we recommend to help verify that the ST350 is working correctly:

3.4.1 Resistance Test

Using a multimeter, read the Wheatstone Bridge opposing node resistances (black and red leads and then the green and white leads). Both readings should be very close to 350Ω ($< \pm 2\Omega$). If the resistances vary significantly from the 350Ω value, the unit may have been deformed by being dropped or mishandled and should be returned to BDI for evaluation.

The ST350 has been designed to minimize the amount of maintenance required to keep it operational. Before each use it is recommended that every sensor be visually inspected for damage and powered on to ensure it is working properly. This should be done two to three weeks before any scheduled testing in case any repairs are required.

3.4.2 Resolution/Noise Test

Ensure the ST350 resolution and electronic “noise” levels are as low as possible for the DAQs analog-to-digital convertor (A/D). Run a short test (approximately 15-20 seconds) at approximately 30 Hz or higher and collect data from the sensors while not being loaded or handled in any way. An example of an output seen for this test can be seen in [Figure 3](#) which illustrates the typical “noise level” with a 24-bit Analog to Digital (A/D) data acquisition system to be around $\pm 0.2\mu\epsilon$. Note that the noise level of the sensor will vary depending on the resolution of the user’s DAQ.

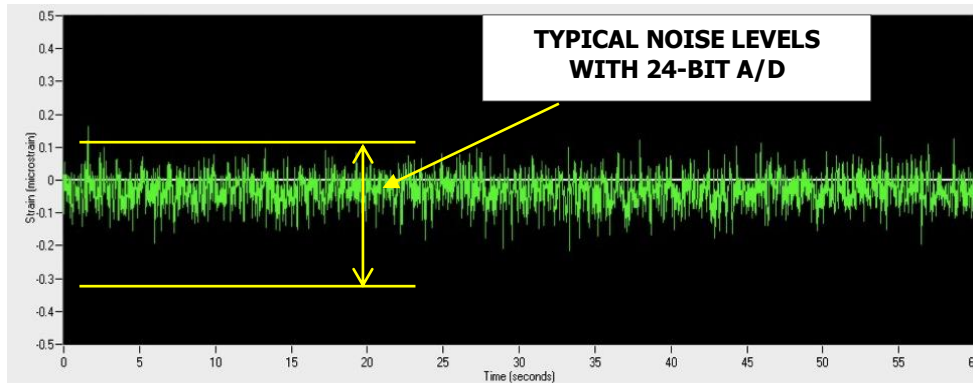

Figure 3: Noise levels of the ST350 on a 24-bit data acquisition system

3.4.3 Sensor Response Test

This test is to ensure the ST350 is producing a smooth output and is returning to its original position. Also ensures that the responses correspond to typical structural testing (positive for tension and negative for compression). Run a test at a sample frequency higher than 30 Hz and apply a smooth tension force (gently pulling on each end) followed by a smooth compression force (gently pushing each end). The output returned should be a tension spike followed by a compression spike and should not appear “stair-steppy”. An alternative test would be to attach the ST350 to a piece of steel or aluminum and then clamp that to a rigid desktop so there is a cantilevered portion where the gage is attached. Run the data acquisition system as described above and then slowly pull up on the “beam” followed by slowly pushing down on the beam. A typical response output for this type of test is shown in [Figure 4](#).

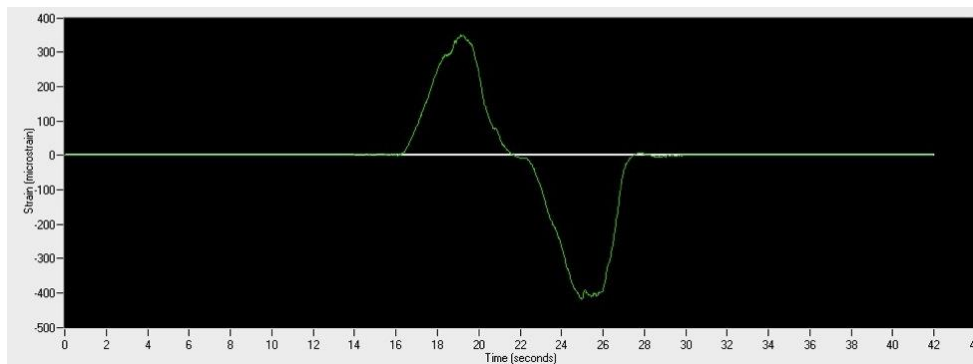

Figure 4: Typical Smooth Output Response and Zero Offset

Using this test data, also ensure the sensor returned to very near zero. In some cases, it may not return exactly to zero due to the sensor being heated up from being handled and/or not being placed on the work surface in the same position as it was sitting before being handled. If a significant offset remains after such a test, this can be an indication of possible damage and the unit should be returned to BDI.

3.4.4 Field Adjusting Excessive Offsets

If it is determined that zeroing the Wheatstone bridge circuit cannot be accomplished with the DAQs circuitry, then it is possible that the ST350 has either been deformed to a point where it is providing too much offset. Note that the sensor is in compliance if offset is within ± 2.5 mV. In cases where there is not time to send the sensor to BDI for evaluation and adjustment, the offset can often be managed in the field after the gage has been installed through the following steps:

1. Loosen the free end of the gage (end opposite of where the cable exits).
2. Put the DAQ in real time monitoring mode and gently push or pull the transducer's free end as required to bring the it into the DAQs balancing range.
3. While holding the free end in place, tighten the mounting nut to specification.
4. Double check that balance can be achieved with the DAQ.

If enough force cannot be applied with the gage attached to the structure to allow it to be balanced, remove the gage and gently apply a tensile or compressive force at both ends by hand. Hopefully, while watching the gage in a real-time output mode, the gage can be brought into the DAQs balancing range.

If excessive offset cannot be removed, please return the ST350 to BDI for evaluation.

3.5 VERIFYING ACCURACY

Often, our customers like to verify the accuracy of their new ST350, something that we encourage them to do. In general, the best way to verify most sensor responses is to use them in a system with well-known responses under load. For example, pressure transducer outputs can be verified through the use of a known height of a column of water.

However, measuring strain involves such extremely small deformations that there are several pitfalls that can be made while trying to evaluate accuracy. In almost all cases we have seen, the measurements have been proven to be correct, but the assumptions made in the "strain application system" have been either incomplete or incorrect.

Remember that these accurate sensors have been designed to help obtain the structure's overall behavior since most evaluations are controlled by flexural, compressive, or shear forces rather than localized stresses at a connection. Therefore, it is best practice to avoid mounting transducers at possible stress concentrations or structural non-uniformities. For measuring local strains in tight areas, either a small foil strain gage or an alternative method such as photo-elasticity is required.



STOP: It is important to understand that the stated resolution and accuracy of a sensor does not guarantee that a measurement can be taken in the field at the stated resolution or accuracy. The physical and mechanical conditions of a test will often impart a practical limit of resolution and accuracy that can be measured. It is the duty of the person responsible for the test to determine where such practical limits apply when using any sensor from BDI or other manufacturers.

3.5.1 Factory Calibration

BDI manufactures an Automated Strain Transducer Calibration System (ASTCS), which has been designed to accurately calibrate the ST350 strain transducers using a precision linear stage coupled with a pair of extremely accurate LVDT transducers. A NIST-traceable calibration kit is used to perform annual accuracy verification procedures. The result is that each ST350 is supplied with a calibration certificate generated by the ASTCS.

3.5.2 Items for Consideration for User Verification Tests

Under no circumstances should loads be applied directly to the ST350. The ST350 is designed with a very flexible geometry, which enables large strains to be measured with little axial load being transmitted through the ST350. Therefore, when testing

typical structural members, the stiffness of the ST350 is inconsequential. The ST350 is intended to provide a measure of strain; it is not a load cell.

Often, the first verification test to be performed is either on a bending beam or compression/tension specimen in a laboratory testing machine, with the results compared to the output of a foil strain gage or the theoretical strain value. Remember that these sensors are designed to measure "axial strain", flexural bending on structural members can be determined via axial strain measurements as long as the applied curvature is relatively small such that the small angle theory is applicable ($\sin \theta = \theta$). This means that if bending stresses are to be measured, it is best to use a beam with a minimum depth of approximately 12 in (305 mm) or more, since the ST350 will actually be offset from the beam surface slightly due to the thickness of the mounting tabs. However, with the beam depth of 12 in (305 mm) or more, this difference is minimal. Another thing to watch out for during a beam bending test; is that it is very difficult to apply the load to the beam without inducing torsion or lateral bending. This occurs because the beam was not perfectly "straight" or because the end conditions are not perfectly level with one another. To minimize this, the ST350 should be mounted with the tab/adhesive technique to the center of the flanges, rather than with C-Clamps on the edge of the flanges.

Attempting to measure strain on a thin strip of metal mounted as a cantilever beam is not a good verification test for these sensors. The primary problem with a thin bending specimen is that a large degree of curvature is required to obtain a small level of surface strain. In other the words, the ST350 will simply be bent rather than elongated. Furthermore, the actual location of the ST350 will be relatively far from the neutral axis compared to the surface (exaggerated again by the thickness of the tabs if they are used). Therefore, significant errors are induced when comparing surface strains obtained by a foil strain gage and the ST350 reading.

For calibration purposes, it is highly recommended that strains be compared at constant moment regions rather than at locations with significant moment gradients. For the "bending beam" type of test, we recommend a beam at least 10 to 12 feet (3 to 4 m) long, with a shorter beam 4 to 6 feet (1 to 2 m) set on top (with "pins" under each end), and the load cell above that. This "4-point" type of setup will supply a constant moment region at mid-span. Remember, the strain measured from the ST350 is averaged over the 3 in (76.2 mm) gage length. Therefore, any error in gage placement or in the assumed strain gradient will cause errors in subsequent data comparisons.

In almost every case we have seen, a specimen that is supposedly undergoing tension only is actually bending as well. A popular test is to use a "dog bone" with the ST350 mounted on one side and then the whole assembly put into tension. It is almost impossible to get pure tension in this setup since the specimen may be slightly bent to begin with and "straightens out" slightly. Also, since the ST350 themselves have a small amount of stiffness, they will cause a non-symmetrical system. Another consideration is the distance of the centroid of the ST350 to the specimen's neutral axis. Since bending will most likely occur, the output from the ST350 may be reduced or amplified since its centroid is about $\frac{1}{4}$ in (6.4 mm) away from the foil gage (further from the neutral axis), and this might be the "compression" or "tension" side of the specimen. This phenomenon is very critical on small laboratory specimens, but insignificant on larger structures where the depths of the sections are usually much bigger.

For the tension test to be successful, the ST350 should be mounted on both sides of the specimen (on all four sides if the stiffnesses are similar in two directions) and the output averaged to determine the tension strain. In addition, the specimen should be relatively stiff compared to the ST350.

If a compression test is being attempted, then the ST350s need to be at least two-member depths away from the ends, (a criterion for plane strain), with ST350's mounted on both sides of the specimen and the data averaged. For compression specimens, it may be necessary to place ST350's on all four sides since it can often be difficult to know the exact orientation of the neutral axis if the stiffness is approximately the same in both directions.

Using reinforced concrete as a test specimen material is a poor choice since inaccuracies in the reinforcement locations and variations in the concrete's elastic modulus (often up to 20%) can cause larger errors than the accuracy range of the ST350. For example, more aggregate near the surface of one gage will affect the modulus in that area. BDI addresses these issues with reinforced concrete by using BDI gage extensions (which effectively multiply the strain over anywhere from two to eight gage lengths). This approach amplifies the signal, thus also improving the signal to noise ratio. With a gage length that is too short, stress concentrations, micro-cracking, or local effects might have an unusually large effect on the measurements.

For reinforced concrete structures (non-pre-stressed or post tensioned), because of the margins of unknowns in concrete modulus, load magnitudes, placement of reinforcement, etc., in general, we prefer not to use measurements where the maximum strain is less than about $30\mu\epsilon$ if we are making conclusions based on the magnitude of strain. (Note that $2\mu\epsilon$ is almost 10% of a $30\mu\epsilon$ peak). This translates into only about 100 psi in concrete and 1ksi in steel, which is quite accurate for analytical

modeling and load rating reinforced concrete structures. For these types of structures, numbers that are claimed to be more accurate are probably suspect. Using the ST350 on pre-stressed concrete will usually provide excellent measurements, not only because there shouldn't be any cracking, but also the concrete modulus usually tends to be more uniform.

We understand that concrete strains are not as accurate as those taken on steel structures and therefore attempt to maximize the accuracy with the gage extensions.

MEASURING THE APPLIED STRAIN OR LOAD:

Often, the output of a strain gage-based load cell is used in a testing machine as the basis for comparisons in tension/compression tests. However, we have found that many of these units may not have been calibrated with N.I.S.T. traceable equipment for years and may be producing inaccurate results. If a gage is manually read for hydraulic pressure, then the result will be sensitive to jacking friction. Also, if stress and strain are being calculated ($\sigma = E \cdot \epsilon$, $\sigma = My/I$, etc.), then very accurate measurements of the cross-sectional areas are required.

MAGNITUDE OF APPLIED LOADS:

Calibration tests should always be run up near the maximum safe linear range of the system. This will give the required confidence that the output from the ST350 is indeed linear over the range of stresses interest.

We are confident that if the above precautions are taken, the ST350 will provide very accurate and reproducible results. If you have any questions on the above discussion or have a lab testing "pitfall" experience that you would like to have us investigate or think it may help other users, please contact us.

4. INSTALLATION

There are several alternative mounting methods that can be used depending on the orientation, location, material being mounted to (steel, concrete, timber), and the length of test (hours, weeks, months, years). Due to the large number of variables associated with adhesive use (thermal cycles, UV exposure, vibration, impact, moisture, corrosion of base steel, etc.,) adhesive is recommended for temporary testing and monitoring applications only. Please contact BDI for further mounting alternatives.

4.1 GENERAL INSTALLATION GUIDE

The ST350 can be installed on many structure types and in all types of applications, so it is impossible to outline all the details for each installation. However, with practice and experience, the user can select from a combination of the mounting techniques that BDI has developed over the years depending on the application. There are several alternative mounting methods that can be used depending on the orientation, location, material being mounted to (steel, concrete, timber), and the length of test (hours, weeks, months, years). Please contact BDI for further information.

4.1.1 Prepare Mounting Area

The ST350 only measures strain in the axis in which it is aligned with, therefore the more accurate the alignment, the more accurate the measurements will be. The easiest way to align the ST350 is to mark a "grid" type pattern for both the proper foot placement and measurement axis. First, locate the center-line of the gaging area in both the longitudinal and transverse directions. For example, if measurements are to be obtained at the mid-span of a joist, locate the midpoint between the supports and the center-line of the joist. The longitudinal mark should be about 8 in (203 mm) long and the transverse mark about 4 in (102 mm) long. This will allow the marks to be seen while the ST350 is being positioned. This can be seen in [Figure 5](#).

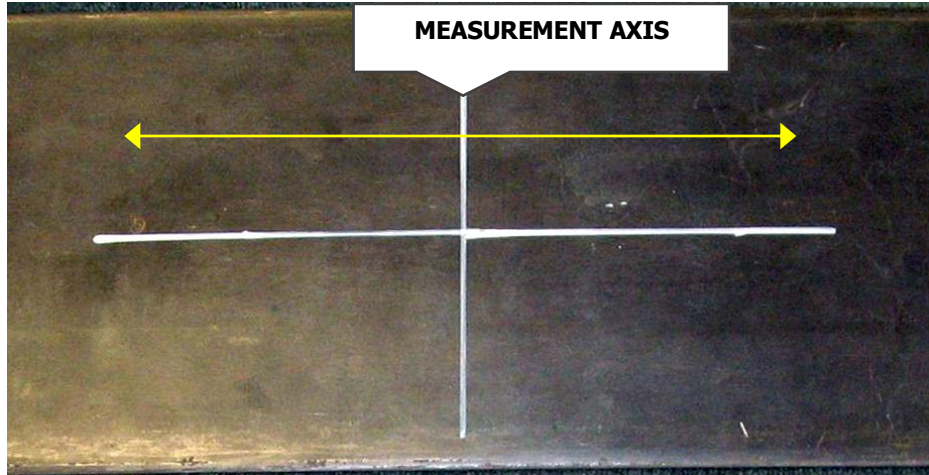

Figure 5: Alignment Marking for ST350 Installation

From the transverse mark, make two additional marks at 1.5 in (38.1 mm) on either side of the centering mark in Figure 6. The rectangular areas below are the portions of the member that the necessary surface preparations must be performed.

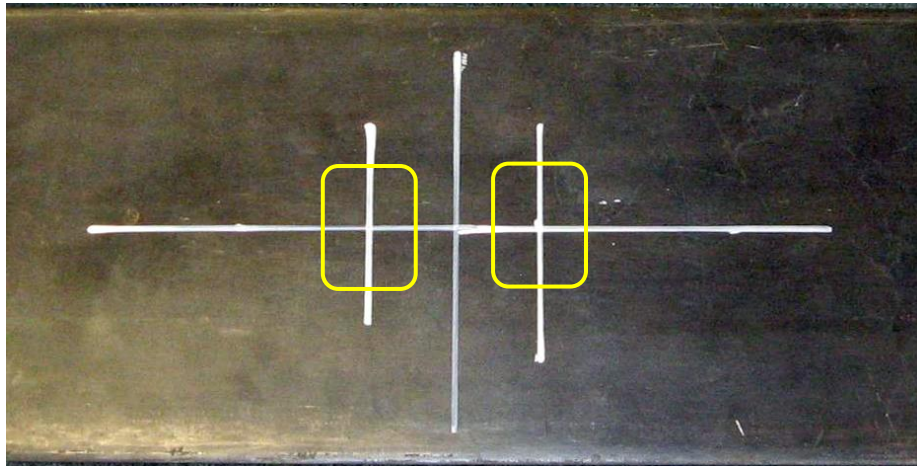

Figure 6: Mounting Position & Surface Preparation Marks

4.1.2 Installation

Once surface preparation is complete, the ST350 can be installed using the selected mounting technique (see Sections 4.2 and 4.3). The two marks 1.5 in (38.1 mm) from the center-line are used to locate the ST350 longitudinally; align these marks with the center of the ST350 feet. Notice that the front of the ST350 (end opposite of the cable) has been machined to a slight point. This point, along with the cable exit on the rear of the ST350, should be aligned with the measurement axis line to ensure that strain is being measured parallel to the measurement axis. An installed ST350 can be seen in Figure 7. Note that if a ST350 extension is used, the longitudinal mark will need to be 30 in (762 mm) long in order to be seen behind the ST350 with an extension installed (see Section 4.1.2). It is important that this line is drawn carefully as the strains are inherently more susceptible to error due to misalignment as the gage length increases.

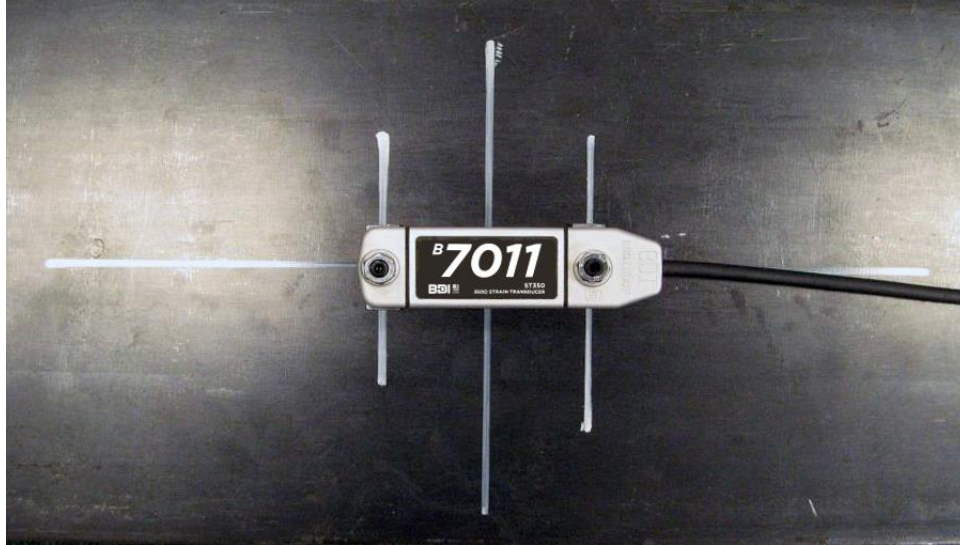

Figure 7: Typical ST350 Installation

4.2 INSTALLATION ON STEEL MEMBERS

In most situations, the most efficient method of mounting an ST350 is using the tab/glue method as it is the least invasive and is truly a “non-destructive testing” technique. The following section outlines an installation for a steel surface.



INFORMATION: BDI manufactures both Imperial (1/4-20) and metric (M6) tabs. To easily distinguish them from each other, BDI has scribed all metric items as seen in Figure 8.

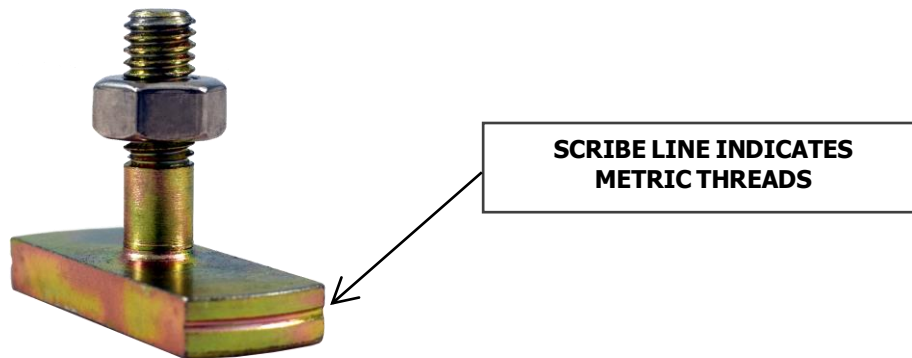

Figure 8: Identifying Metric vs. Imperial Tabs

Place tabs in the machined slots of the ST350 Tab Jig and then place the ST350 on the positioned tabs as seen in Figure 9. Thread on the 1/4-20 (or M6) nut and tighten to approximately 40 in-lb.



Figure 9: Mounting Tabs on the ST350 using the Tab Jig



WARNING: Be careful not to over tighten the nuts on the tabs, over tightening may result in bending the ST350. If the ST350 has been bent out of alignment, please send the ST350 back to BDI for realignment and recalibration.

1. Locate the centerline of the gaging area in both the longitudinal and transverse directions. First, locate the midpoint and draw two centerlines as shown in Figure 10. The longitudinal centerline should be approximately 4 in (100 mm) long and the transverse centerline should be approximately 2 in (50 mm) long. This will allow the marks to be seen while the strain gage is being positioned.

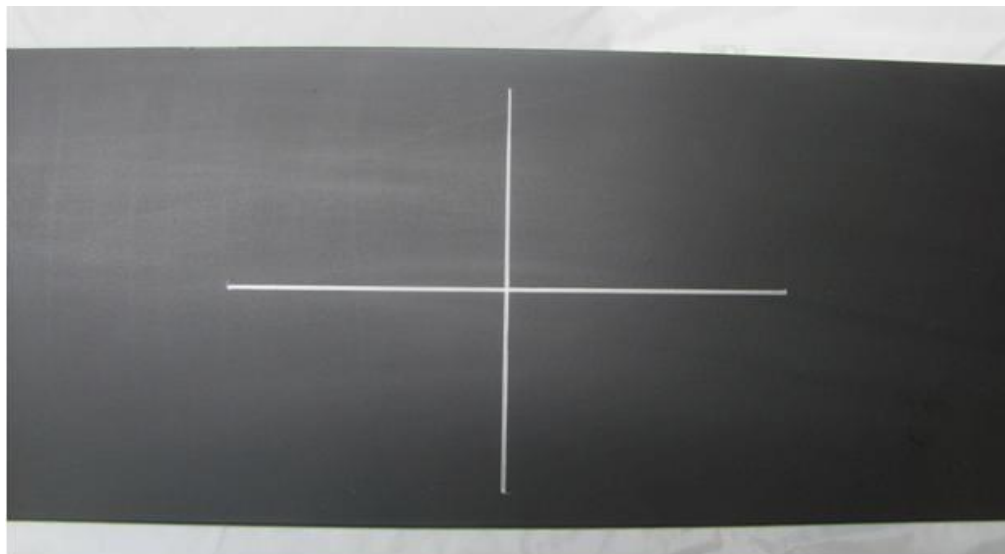

Figure 10: Marking ST350 Center Mounting Location

2. Remove paint or scale from the area where the two lines intersect using a power grinder until a clean metal surface is obtained.



CAUTION! Proper personal protection equipment such as safety glasses, ear plugs, and face masks should be utilized during grinding operations! Also, grinding steel will produce sparks that can ignite flammable liquids and other materials, so be careful!

3. Next, very lightly grind the bottom of the tab that has already been mounted to the sensor to remove any oxidation and/or other contaminants. Before mounting, set the sensor in the location it is to be attached, and ensure that the unit is flush to the surface as this is important for achieving a good bond and that the measurement axis is perpendicular to the surface.
4. Apply a thin line of adhesive to the bottom of the tab (see "Information" below) about ¼ in (6.4 mm) wide. Mount the sensor in the marked location, and then pull it away. This action will apply adhesive to the structural member at tab location.
5. Spray the adhesive spot on the structural member with a "light shot" of the adhesive accelerator (Loctite Tak Pak 7452, Part # 18637 in 0.7 oz aerosol spray container).
6. Very quickly, mount sensor in its proper location and apply a light force to the top of the tab for approximately 15-20 seconds.



INFORMATION: Loctite 410 is suggested to be used for short installations, such as a load test.

Loctite H4500 suggested for applications where Loctite 410 is not adequate, such as longer duration load tests, high force application, or temporary monitoring applications.

To find the closest Loctite Distributor please call 1 (800) 243-4874 or visit www.loctite.com

If the above steps are followed, it should be possible to mount each sensor in approximately five minutes. Often, the above approach will make removing the tabs very difficult from steel members due to the strength of the glue. BDI has developed a Tab Removal Tool (TRT) to help reduce the possibility of damaging sensors and tabs (see Figure 11). Each TRT has a hex head machined into bottom face for tightening and/or loosening the designated nut size, and the small hole in the face of the hex head has been threaded to capture the threaded stud.

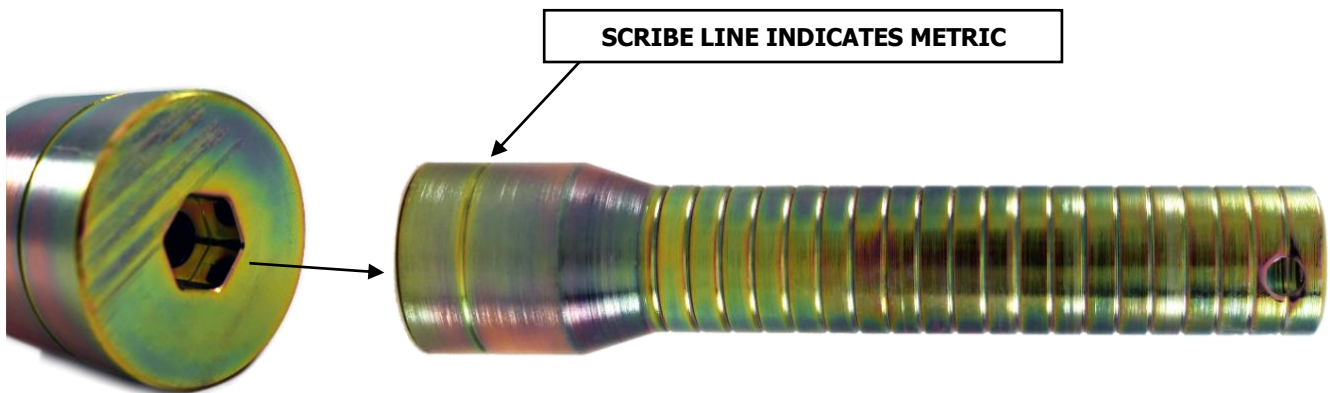

Figure 11: Tab Removal Tool (TRT)



INFORMATION: Please remember that BDI manufactures both imperial (1/4-20) and metric (M6) tabs. Ensure that the matching TRT threads are used with the tabs.

The following instructions describe the method used to remove a sensor that has been mounted to a steel surface. If a TRT is not available, a pair of vise grips can be used to remove the tabs, but there is a greater chance of damaging the tabs using a vise grip.

1. Use the cutout in the TRT or an end wrench; remove the nuts from the tabs. Carefully slide the ST350 from the tabs.

- Thread the TRT on to the tab until the face is flush with the foot of the tab as seen below. If a gap remains between the TRT and the tab foot, there is a high likelihood that the stud will be bent in the next step. Also, do not over tighten the tab into the TRT or it will be hard to remove the tab from the TRT. After a few tries this process will become a simple procedure.



Figure 12: TRT with a Tab Inserted

- In the direction of "thin" axis of the tab, give the TRT a quick tug or tap and the tab should pop off the member surface. Depending on how well the tab is fixed, particularly on a steel surface, more force may be required. In this case, simply hit the handle of the tool with a small rubber mallet. Note that holes in the top of the tool have been supplied so that a lanyard can be added if necessary.

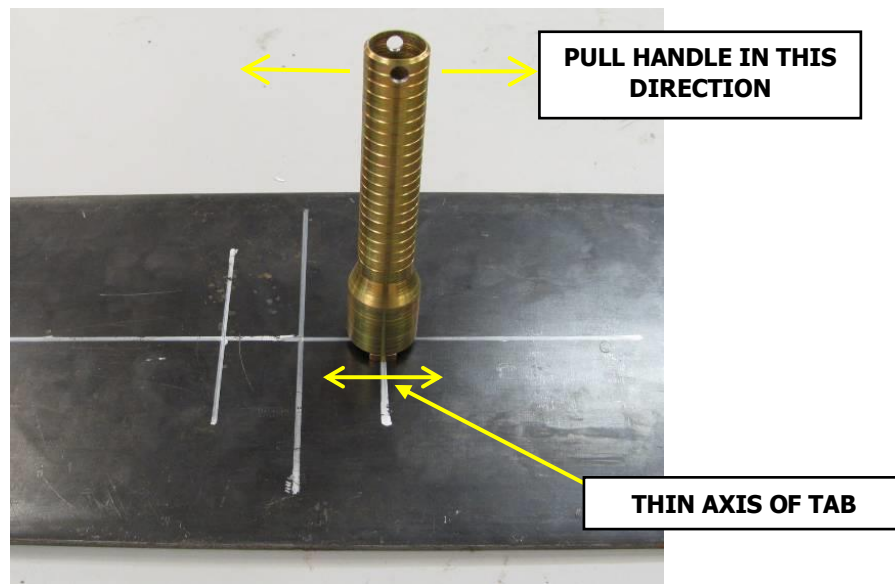

Figure 13: Removing a Tab with the TRT

- Unthread the tab from the TRT and continue with the other sensors. If the tab remained with the sensor during removal, use vice grips to hold the foot of the tab while loosening the nut.

The tabs can be re-used by soaking them in acetone for 30-40 minutes to remove the hardened adhesive. Be sure to cover the container since the acetone will evaporate quickly and is very flammable! The mounting tabs have been designed to be reusable by simply dissolving the glue with acetone. Acetone can be reused multiple times, but if it becomes too saturated with glue it will start leaving a thin layer of glue in the threads of the mounting tabs. Also, sometimes when the mounting tabs are removed from a structure, the top threads can be chipped. If it becomes hard to thread nuts onto the mounting tab stud, run a $1/4$ -20 (or M6) die down the threads to remove these chips and glue from the threaded stud.

4.1 INSTALLATION ON CONCRETE MEMBERS

In general, the basic “tab and glue” technique described above is suitable for most concrete member applications, however, if any of the following parameters exist; BDI recommends using mechanical anchors rather than glue:

- + If concrete is moist or wet
- + If the sensor must remain in place for more than a day or two
- + If the instrumented areas are directly over automobile or train traffic where if the sensor came loose, it could create a hazard.
- + If the instrumented area is difficult to re-access during the testing period in case sensor comes loose.
- + If it is judged that the tab/glue system is sufficient, some extra steps should be followed when using this method for concrete members. The primary concern when mounting sensors on either reinforced or pre-stressed concrete is that the surface must be clean, dry, and dust-free in order for the glue to adhere to. Therefore, it is highly recommended that compressed air (either in cans or from an air compressor) be used to remove the dust after grinding has been completed. Follow the above steps as outlined for steel, except just prior to applying the glue to the tabs, use the compressed air to clean any surface dust away from the mounting point.

4.1.1 Concrete Mounting Studs

If it is judged that the conditions warrant a more secure mounting system, then threaded mounting studs can be used. These will require holes to be accurately drilled 3 in (76.2 mm) apart in the concrete with a hammer drill as described below.

Locate the first gaging point on the structure and using a concrete drill, drill a 1/4 in hole approximately 1 in deep. If mounting to pre-stressed concrete, ensure to avoid drilling into the pre-stressing tendons.

1. Drop in a 1/4-20 x 1.5 in Power Fasteners Power-Stud or similar and lightly tap in with a hammer to set.
2. Slide on the short side of the ST350 drilling jig on to the stud and tighten the jig in-place and make sure it is properly aligned with the gage installation markings (see [Figure 14](#)). Tightening the ST350 concrete jig will also serve to set the anchor into the concrete properly.



Figure 14: ST350 Concrete Drilling Jig

3. Use the second open hole in the ST350 concrete drilling jig to drill the second hole for the concrete stud.
4. Once the hole is drilled, remove the ST350 concrete drilling jig and insert the second drop in a 1/4-20 x 1.5 in Power Fasteners Power-Stud or similar and lightly tap in with a hammer to set and then tighten the stud in-place with a large washer and nut to set the stud in the concrete.
5. Remove the nut and washer and slide the sensor over the studs.

6. While holding the sensor in place, screw the nuts on the stud and tighten with an open-end wrench or torque wrench to approximately 40 lb-in.

Special aluminum gage-lengthening extensions have been designed for use with the ST350 generally used to measure surface strains on reinforced concrete (R/C) structures; however, they can also be used to mechanically amplify the sensor output. The aluminum extensions simply increase the ST350 gage length to allow an “averaged” strain value to be recorded with the presence of cracks associated with most R/C structures. These units allow seven additional gage lengths, each one an integer multiple of the original 3 in (76.2 mm) ST350 gage length.

4.1.2 Attaching ST350 with Extension to R/C Members

There are three items to consider when selecting an appropriate gage length for a particular R/C member. The first is that it must be long enough to minimize the effects of flexural cracks. There are several factors that control crack formation in concrete, primarily the beam depth, steel ratio, concrete strength, and bond strength. While there are no precise methods for determining a minimum crack spacing, it has been determined experimentally that a gage length equal to the member depth (d) is satisfactory for slabs and rectangular beams and 1.5 times the depth is suitable for T-beams. The second item to consider is that the gage length should be short enough that the measured strains are not significantly affected by moment gradients and curvature. An upper limit of $1/20^{\text{th}}$ the span length (L) will usually maintain the gradient below 5%. In general, it is desired to obtain as long a gage length as possible without exceeding the upper bound. Table 5 provides the recommended lower and upper gage length limits for R/C members.

Table 5: ST350 Extension Limits

RECOMMENDED LOWER AND UPPER GAGE LIMITS		
STRUCTURE TYPE	LOWER LIMIT	UPPER LIMIT
SLABS & RECTANGULAR BEAMS	1.0 X DEPTH OF MEMBER	LENGTH OF SPAN / 20
T-BEAMS	1.5 X DEPTH OF MEMBER	LENGTH OF SPAN / 20

To reduce the strain data, remember that the recorded strains have been “amplified” by the integer multiple of the gage length. For example, if the longest possible gage length is used 24 in (610 mm), this is eight times the standard gage length. Therefore, the data will need to be divided by eight to arrive at the correct “averaged” strain. In addition, an amplification factor of 1.1 will need to be applied to the output to account for the extension effect.

Example of adjusting the output to account for Gage Extension use:

This example is using a ST350 with an 18 in extension. All data was collected using the calculated calibration factor and the output is in engineering units. The applied multiplier is calculated as follows, see Table 6 for the factors to apply:

$$Reading = \frac{Reading}{Ext. Multiplier} \times Amplification Factor$$

Table 6: Gage Extension Factors

GAGE EXTENSION LENGTH	EXT. MULTIPLIER	AMPLIFICATION FACTOR
6 in	2	1.1
9 in	3	1.1
12 in	4	1.1
15 in	5	1.1
18 in	6	1.1
21 in	7	1.1
24 in	8	1.1



INFORMATION: In most cases, the live-load strain magnitudes recorded on reinforced concrete structures have been less than 100µε.

Another item to consider is the available strain range of the ST350. As the gage length is progressively increased, the force on the ST350 imposed by the extension is increased as well for a given amount of strain. This has the effect of reducing the available strain range for the ST350 with extension assembly. The upper limit of the strain range recommended for the ST350 is approximately ±4000µε. However, to minimize the force in the system and to avoid the mounting tabs from popping off the concrete members during loading, BDI recommends keeping the maximum strain in the ST350 to about 1,000µε. Table 7 has been developed to indicate the maximum strain ranges for each available gage length. Higher strains can of course be measured; however, special attention should be paid to the gain settings on the data acquisition equipment being used.

Table 7: Maximum Strain Ranges

EXT. MULT.	ACTUAL GAGE LENGTH WITH EXTENSION	MAXIMUM STRAIN RANGE	APPROX. CONC. STRESS FOR F'C = 3,000 PSI (20.7 MPa)	APPROX. CONC. STRESS FOR F'C = 4,000 PSI (27.6 MPa)	APPROX. CONC. STRESS FOR F'C = 5,000 PSI (34.5 MPa)	APPROX. STEEL RE-BAR STRESS
1	3 in (76.2 mm)	±1000 µε	3.1 ksi (21.4 MPa)	3.6 ksi (24.8 MPa)	4.0 ksi (27.6 MPa)	30 ksi (207 MPa)
2	6 in (152.4 mm)	±500 µε	1.6 ksi (11.0 MPa)	1.8 ksi (12.4 MPa)	2.0 ksi (13.8 MPa)	15 ksi (103 MPa)
3	9 in (228.6 mm)	±330 µε	xx ksi (6.9 MPa)	1.2 ksi (8.3 MPa)	1.3 ksi (9.0 MPa)	9.9 ksi (68.3 MPa)
4	12 in (304.8 mm)	±250 µε	780 psi (5.3 MPa)	900 psi (6.2 MPa)	xx ksi (6.9 MPa)	7.5 ksi (51.7 MPa)
5	15 in (381.0 mm)	±200 µε	625 psi (4.3 MPa)	720 psi (5.0 MPa)	800 psi (5.5 MPa)	6.0 ksi (41.4 MPa)
6	18 in (457.2 mm)	±160 µε	500 psi (3.4 MPa)	575 psi (4.0 MPa)	650 psi (4.5 MPa)	4.8 ksi (33.1 MPa)
7	21 in (533.4 mm)	±140 µε	440 psi (3.0 MPa)	500 psi (3.4 MPa)	560 psi (3.9 MPa)	4.2 ksi (29.0 MPa)
8	24 in (609.6 mm)	±125 µε	390 psi (2.7 MPa)	450 psi (3.1 MPa)	500 psi (3.4 MPa)	3.8 ksi (26.2 MPa)

4.1.3 Attaching Extension to the ST350

Once a gage length has been determined, there are three possible scenarios for mounting the ST350 with extension to the structure:

- 1. Adhesive/tabs on both ends:** If conditions are dry, the concrete surfaces relatively smooth, and testing will not last more than a day, the tab/adhesive system will usually work fine as described in the previous sections. This is the preferred method of BDI, generally with a good air compressor the surface can be dried off enough to allow the glue to set properly.
- 2. Adhesive/tab on ST350 end and a masonry anchor on the extension end:** Again, if conditions are dry, then the adhesive/tab system on one end will be sufficient for a couple of days of testing, as long as the other end is securely mounted with a mechanical anchor. It is highly recommended to use masonry screws such as 1/4-20 x 3.25 in concrete studs or another type of masonry anchor (readily available at most hardware stores) to install ST350/extension assembly due to the additional weight of the extension.
- 3. Anchor/masonry anchor on both ends:** Use this approach only when the structure is wet and/or very rough.

i

INFORMATION: In any of the above scenarios, the steps outlined in the previous section should be used for surface preparation and mounting procedures. The extension jig is used to ensure that the ST350 is aligned properly with the extension. If using the anchor mounting on both ends, omit the mounting tabs.

Using the ST350 extension jig (Figure 15), insert a tab into the slot on the end of the jig. Set the ST350 over the tab into using the mounting hole closest to the cable exit and loosely thread on a nut.



Figure 15: ST350 Extension Mounting Jig

There is a machined hole in the non-cabled end of the ST350 that will capture a standard ¼-20 (or M6) hex head bolt (see Figure 16). Simply insert the bolt through the bottom of the ST350 and twist until the bolt head drops into the hole. There is a relief cut in the back of the extension to accept the protrusion on top of the gage. This will ensure that the gage is positioned correctly.

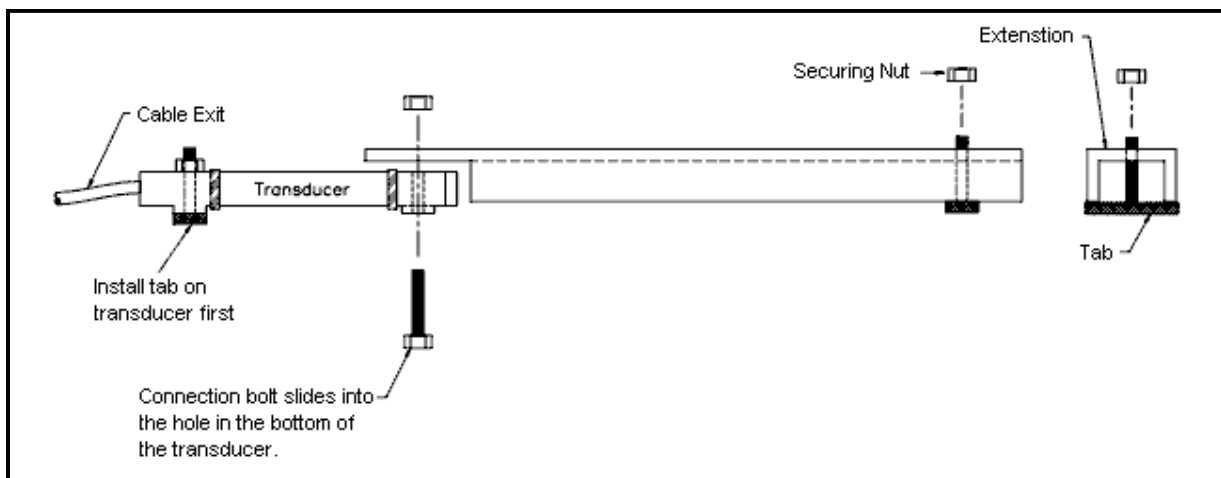

Figure 16: ST350 Extension Mounting Diagram



Figure 17: Aligning ST350 and Extension in the Jig

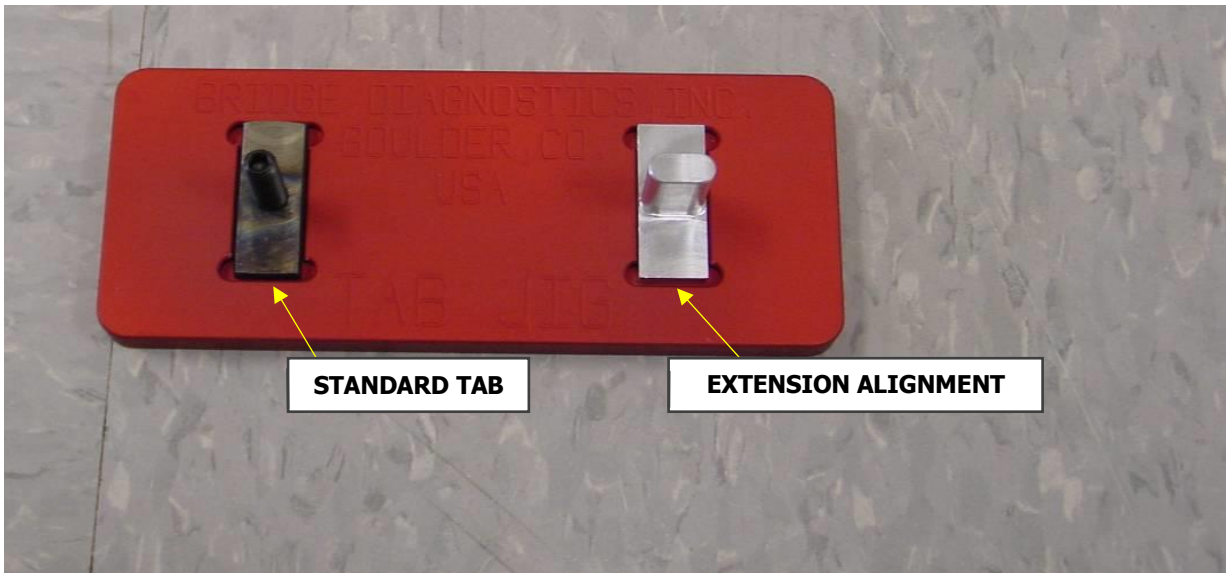

Figure 18: Extension Alignment Tab



Figure 19: Attaching Tab to Extension

X

CAUTION! Once the extensions have been installed, the ST350 is much more susceptible to damage during handling due to the large extension “lever”. To minimize possible damage, place the ST350/extension assemblies in a plastic five-gallon bucket with the extension ends down. This will allow for many assemblies to be carried at once and still be relatively protected.



Figure 20: ST350 With Extensions Attached to an R/C Structure

It may be noted during testing that there is significantly more drift due to ambient temperature changes once the extensions are installed. This is due to the relatively low thermal inertia of the ST350/extension assembly compared to that of the concrete structure. The best solution is to run the tests on a day when the temperature is remaining constant. This is not always possible; therefore, the drift can be minimized, particularly for assemblies that receive direct sunlight (on top of the deck, on the parapet, etc.), by covering the gage and extension with an insulating material. Often, a temporary cover of foam attached with aluminum tape can protect them from wind and direct sunlight. Alternatively, BDI can provide aluminum insulated gage covers that can be mounted temporarily or permanently.

After the test has been completed, extreme care must be taken in removing the securing nuts from the tabs, as often tabs will have a tendency to “twist off” at the glue line, particularly if the concrete is slightly rough or not cleaned off properly. Do not attempt to remove the extension from the ST350 while the assembly is still mounted to the structure. Back off the securing nut between the ST350 and extension by holding the extension only. If the tabs are still attached to the ST350 or extension after removal from the structure, use vice grips to hold the bottom of the tab while the securing nut on top is removed. Again, never use the ST350 as a lever!

i

INFORMATION: To find the closest Loctite Distributor please call 1 (800) 243-4874 or visit www.loctite.com

Loctite 410 is suggested to be used for short installations, such as a load test.

Loctite H4500 suggested for applications where Loctite 410 is not adequate, such as longer duration load tests, high force application, or temporary monitoring applications.

4.2 INSTALLATION ON OTHER SURFACES

4.2.1 Timber Members

If the ST350 is to be mounted to a timber member or other relatively soft materials, use a 1.5 in self-tapping screw and a power screwdriver. If the wood has any sort of glue laminated section or it has been chemically treated, it is recommended that a pilot hole be drilled.

4.2.2 Composite Materials

If attaching the ST350 to a composite material like Carbon Fiber Reinforced Material (CFRP), we recommend consulting with the manufacture on the correct procedure for removing any surface debris or manufacturing residue.

5. MAINTENANCE & RECALIBRATION

5.1 MAINTENANCE CONSIDERATIONS

The ST350 units themselves are sealed and cannot be serviced with the exception of being kept clean with a rag and something similar to window cleaner. Remove any adhesive carefully with a rag and very small amount of acetone.

5.2 RECALIBRATION

Calibration is performed on each ST350 and a unique Calibration Certificate is shipped with each sensor. This certificate certifies that the sensor is traceable to NIST Standards. If this sensor is out of specification or appears to be bent, it can be sent to BDI straightening and re-calibration. We recommend that the ST350 is recalibrated on an annual basis; however, this depends on the frequency of use.

In order to meet the IP67 weather resistant rating, the sensor has been potted with a non-re-enterable encapsulant. Due to this design, the only replacement part available for the sensor is the cable. For the cable to be replaced, the sensor should have at least twelve in of cable exiting the sensor body. This cable can be spliced to a new cable of the proper length.



INFORMATION: If a sensor is damaged beyond repair, the sensor may be replaced at a discounted price to the original purchaser. Please contact Bridge Diagnostics, Inc. or the local distributor to obtain authorization for return.



RAW DATA. REFINED RESULTS.

**DATA YOU CAN TRUST.
RESULTS YOU CAN BUILD ON.**

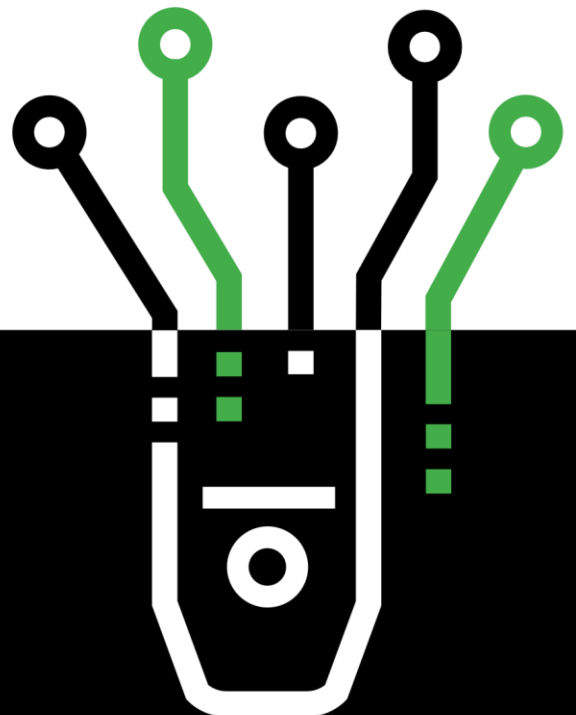

P +1.303.494.3230 740 S PIERCE AVE UNIT 15
F +1.303.494.5027 LOUISVILLE CO 80027

BDITEST.COM
sales@bditest.com