



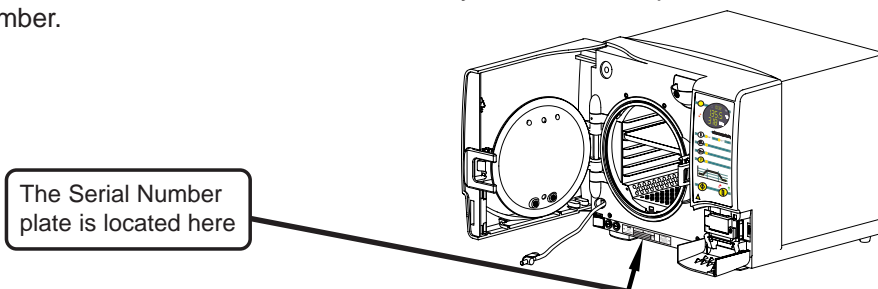
# Service Manual

## ***Read these Instructions before use***

**Keep this 'Service Manual' in a safe convenient place for future reference.**

## ***Eschmann After Sales Service Department***

The Eschmann After Sales Service Department is staffed and equipped to provide advice and assistance during normal office hours. To avoid delays when making enquires, please quote the Model and Serial Number of your Autoclave which is shown on the Serial Number plate, the location of which is shown below. Please ensure you include all alpha and numeric digits of the Serial Number.



**For further information visit [www.eschmann.co.uk](http://www.eschmann.co.uk)**

All correspondence relating to the after sales service of Eschmann Equipment to be addressed to :

### ***UK Customers***

**Eschmann Equipment, Peter Road, Lancing, West Sussex BN15 8TJ, England.  
Tel: +44 (0) 1903 765040. Fax: +44 (0) 1903 762006.**

### ***Overseas Customers***

**Contact your local distributor. In case of doubt contact Eschmann Equipment.**

## ***Patents and Trade marks***

The ESCHMANN name and logo are registered trade marks of Eschmann Holdings Limited.

"Eschmann Equipment" is a trading name of Eschmann Holdings Limited.

"LS5", "Little Sister", "QuickVac" and "SES2555" are trade marks of Eschmann Holdings Limited.

Patents : Patents Pending plus - Pat. US5090033 and Pat. GB2238407

## ***Copyright © 2003***

All rights reserved. This booklet is protected by copyright. No part of it may be reproduced, stored in a retrieval system or transmitted in any form or by any means, electronic, mechanical, photocopying, recording or otherwise without written permission from Eschmann Holdings Limited.

The information in this publication was correct at the time of going to print. The Company, however, reserves the right to modify or improve the equipment referred to.

**CE** If the CE mark is affixed to the product, it indicates compliance with Council Directive 0473 93/42/EEC of 14 June 1993 concerning medical devices.

### CONTENTS

#### **1 Introduction**

1 Introduction	4
----------------	---

#### **2 Description**

2 Description	4
---------------	---

#### **3 Operating controls & display**

3 Operating controls & display	4
Push buttons	4
Digital displays	5
Indicators	5

#### **4 Autoclave components**

4 Autoclave components	5
------------------------	---

#### **5 Operation cycle**

5 Operation Cycle	9
-------------------	---

#### **6 Cycle details**

6 Cycle Details	10
-----------------	----

#### **7 Maintenance**

7 Maintenance	12
7.1 Special functions	12
7.2 Protected functions	12
7.3 Errors and faults	12
Power failure	12
Aborted cycles and errors	12
Reset thermostat (overheat)	12
7.4 Calibration	13
7.5 LED Function test	13
7.6 Connections, air, water and electrical	13
7.7 Safety checks (Weekly & Annual)	13

#### **8 Part removal & replacement**

8 Part removal & replacement	30
8.1 General	30
8.2 Fuse renewal	30
8.3 Cover removal & replacement	30
8.4 Chamber solenoid valves	31
8.5 Reservoir	31
8.6 Mains transformer	32
8.7 Power board	32
8.8 Door microswitches	32
8.9 Door lock/open solenoids	32
8.10 Door lock magnetic catch	32
8.11 Chamber temperature sensors	32
8.12 Heating element	32
8.13 Door seal	32
8.14 Vacuum pump	33
8.15 Cooling fan	33
8.16 Bacterial air filter	33

8.17 Gauze filter	33
8.18 Printer	33
8.19 Safety valve	33
8.20 Band heater temp. sensor	33
8.21 Mains switch	33
8.22 Band heater	33
8.23 Chamber water level sensors	33
8.24 Reset thermostat (overheat)	34
8.25 Cycling thermostat	34
8.26 Thermal fuse	34
8.27 Display board	34
8.28 Mains fuse holders	34
8.29 Membrane key pad	34
8.30 Reservoir level sensor	34
8.31 Water pump	35
8.32 Test probe port and pressure gauge	35
8.33 Door	35
8.34 Band heater resettable thermostat	35
8.35 Vacuum pump maintenance	35
8.37 Pressure door lock	36

#### **9 Technical data**

9 Technical data	48
------------------	----

#### **Parts lists**

Parts list 1	
Electrical	39 - 41
Parts list 2	
Pipes and plumbing	43
Parts list 3	
General assembly	45 - 47

#### **Tables**

Table 1	Key to display A2	10
Table 2	Special functions	15
Table 3	Protected functions	17
Table 4	Fault diagnosis & error number details	22
Table 5	Protected function P7 quick reference	29

#### **Figures**

Fig.1a	Control panel (SES2555/LS5)	5 + 51
Fig.1b	Control panel (SES2555/QuickVac)	5 + 51
Fig.2	Main components (covers on)	6
Fig.3	Main components (covers off)	7
Fig.4	Main components (covers off, non-vacuum)	8
Fig.5	Pipe connections and identification	14
Fig.6	Vacuum pump part identification	35
Fig.7	Parts list 1 - Electrical	38 and 40
Fig.8	Parts list 2 - Pipes and plumbing	42
Fig.9	Sheet 1 Parts list 3 - General assembly	44
Fig.9	Sheet 2 Parts list 3 - General assembly	46
Fig.10	Schematic electrical diag. (non-vacuum)	49
Fig.11	Schematic electrical diag. (vacuum)	50

#### **Appendix 1**

Appendix 1	37
------------	----

## 1 Introduction

### WARNING

Read this service manual before servicing the autoclave and keep it in a safe convenient place for future reference. Always have at hand the 'Instructions for Use' as supplied with the autoclave and be familiar with the cautions and warnings contained within it. The servicing of this autoclave should be under the control of a competent person with sterilization training. The autoclave should only be serviced as specified by the manufacturer and detailed within these service instructions.

1.1 This service manual applies to the following autoclaves, fitted with software version 1.51 or later (software version is displayed briefly when the autoclave is switched 'on' or **B1** is pressed):-

**SES Little Sister 5 Autoclave** (from Serial Number L5NA3C1001) REF 87-060-01

**SES Little Sister 5 Vacuum Autoclave** (from Serial Number L5SA3C1001) REF 87-060-25

**SES QuickVac Vacuum Autoclave** (from Serial Number LQSA3D1001) REF 87-061-47

**SES 2555 Autoclave** (from Serial Number S5NA3C1001) REF 87-060-61

**SES 2555 Vacuum Autoclave** (from Serial Number S5SA3C1001) REF 87-060-73

**SES 2555 Vacuum Autoclave** (from Serial Number SQSA3D1001) REF 87-060-73

**SES 2555 Autoclave - Australian** (from Serial Number S5NA3C1001) REF 87-061-09

**SES 2555 Vacuum Autoclave - Australian** (from Serial Number S5SA3C1001) REF 87-061-21

**SES 2555 Autoclave - Singapore and New Zealand** (from Serial Number S5NA3C1001) REF 87-060-85

**SES 2555 Vacuum Autoclave - Singapore and New Zealand** (from Serial Number S5SA3C1001) REF 87-060-97

1.2 This Service Manual contains a technical description, complete maintenance procedures and an illustrated list of spare parts that are available from the Eschmann After Sales Service Department.

1.3 Ensure that routine servicing is carried out at regular intervals by either Eschmann trained personnel or suitably trained engineers only, otherwise the warranty could be infringed.

1.4 Keep the 'Instructions for Use' and this 'Service Manual' readily accessible for reference purposes prior to and during operation, cleaning and servicing of the autoclave.

### CAUTION

In common with other systems containing static water reservoirs, water used in this unit can become contaminated over a period of time, or following an aborted cycle, and should be treated as a potential risk of infection.

**Note:** When sterilizing lubricated dental handpieces, the reservoir water should be changed every week to prevent contamination of the door seal, and other elastomer components, used in the pressure system.

1.5 It is recommended that the reservoir is drained, allowed to dry and refilled with water\* every week. At every service interval the reservoir **must be removed, thoroughly cleaned and dried** (see section 8.5), and then refilled with water\*.

\* **DO NOT USE TAP WATER** Eschmann recommend the use of 'Sterile Water for Irrigation' alternatively clean distilled or deionized water, or water treated by reverse osmosis may be used.

## 2 Description

2.1 The autoclave is a portable steam unit heated by an electric element (or elements depending on the model). For sterilization of wrapped loads the vacuum unit creates a vacuum in the chamber. The unit is supplied to suit the mains electrical supply shown in the technical data section.

2.2 The autoclave is electronically controlled and has various sterilizing programmes as detailed in the 'Instructions for Use'. For typical sterilization cycle times, refer to the technical data section.

2.3 The required sterilizing cycle is selected by pressing various buttons on the control panel. LEDs illuminate to show which temperature and cycle have been selected. The cycle is started by pressing the start button. The sterilizing/drying cycle proceeds automatically until complete and the printer (if fitted) starts automatically when the start button is pressed.

2.4 Indication of cycle status or error codes during a cycle are provided by the digital display and printer (if fitted).

## 3 Operating controls & display

3.1 The following operating controls and displays are all positioned on the front of the unit. Their use is explained in greater detail within the 'Instruction for Use'.

**Mains switch** The symbol 'I' indicates 'on' and the symbol 'O' indicates 'off' (see 9, Fig. 2).

**Push buttons (see Fig. 1a and 1b)**

**B1 Display change button.** Press **B1** to display the cycle counter in display window **D1**.

**B2 Cycle temperature button.** Each time **B2** is pressed the cycle temperature alternates between 134°C and 121°C.

**B3 Unwrapped load (with drying) cycle button.**

**B4 Unwrapped load (without drying) cycle button.**

**B5 Programme 'P' button.** For details see Section 7.2.

**B6 Cycle start button.** (Always press and hold)

**B7 Open door button.** (Always press and hold)

**B8 Single wrapped load (with drying) cycle button.** (Vacuum autoclaves only)

**B9 Hollow instruments (without drying) cycle button.** (QuickVac and later SES2555 models only)

**Note:** During some maintenance procedures you can press and hold buttons to scroll display data quickly.

**Digital displays (see Fig. 1a and 1b)**

**D1 Time, cycle counter, error number display or minutes left during sterilization or drying phase.**

For more details on the error codes see Table 4.

**D2 Temperature display.**

**D3 Pressure display.**

**NOTE:** Displays may show other information in special functions mode, see the 'Special functions table'.

**Indicators (see Fig. 1a & 1b)**

**A1 Low water indicator.**

**A2 Process display indicator.** (See Table 1 in the instruction for Use).

**A3 Door unlocked indicator.**

**A4 Door locked indicator.**

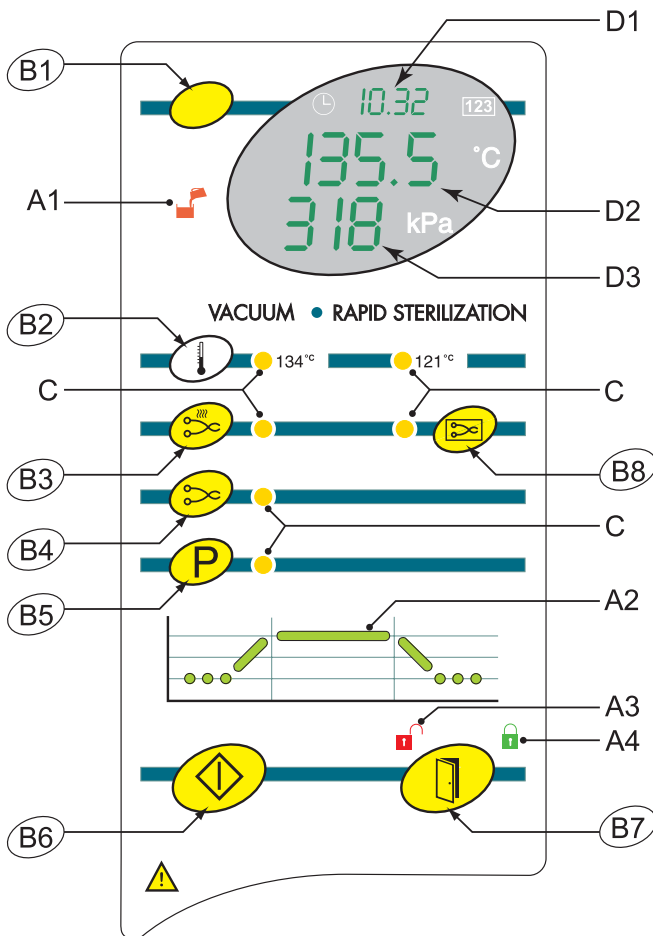
**C Selection indicators.** These indicators illuminate to show which function has been selected (cycle or temperature).

### 4 Autoclave components

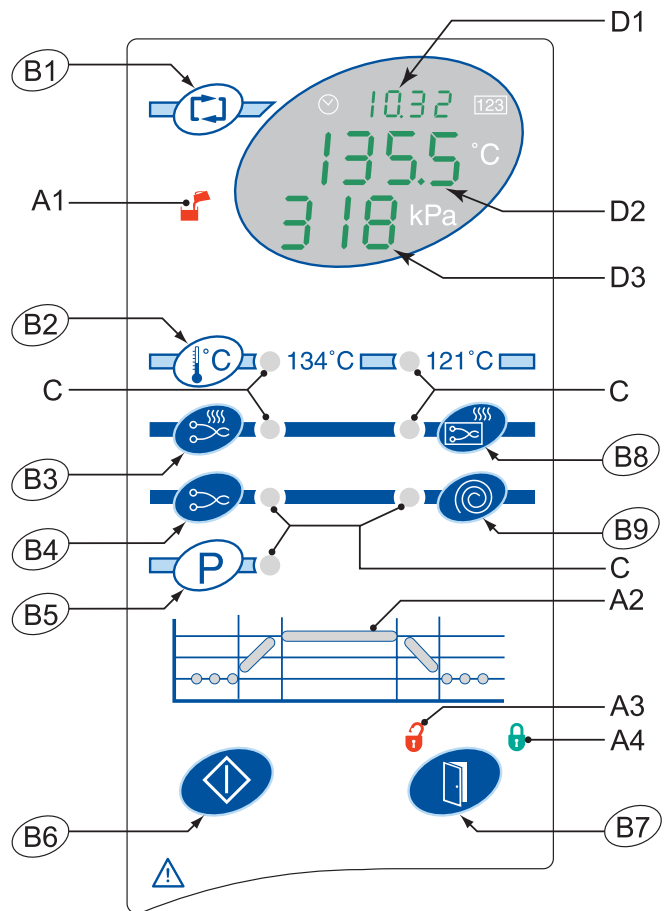
4.1 The following components and equipment are incorporated in the autoclave. They are illustrated in Fig.2, 3 and 4. Fig.2 shows the autoclave with covers on Fig. 3 and 4 with covers off. In Fig. 2 and 3 the vacuum unit is shown, some components are particular to the vacuum unit only (vacuum and QuickVac models are similar apart from the control panel). Fig.4 shows the position of components peculiar to the non-vacuum unit and some common components.

Door close solenoid, Fig.3 item 8. This is operated when the door closed microswitch (Fig.3 item 19) is actuated by closing the door. The lock (Fig.3 item 12) holds the door closed until the sterilizing cycle is complete. It will also keep the door closed under all fault conditions. As absence of power is also a 'fault' the unit power switch must be set to 'on' in order to open the door. (See errors and error clearing section).

**NOTE: FOR EASY REFERENCE THESE FIGURES (1a & 1b) ARE REPEATED ON A FOLD OUT AT THE BACK OF THIS MANUAL**

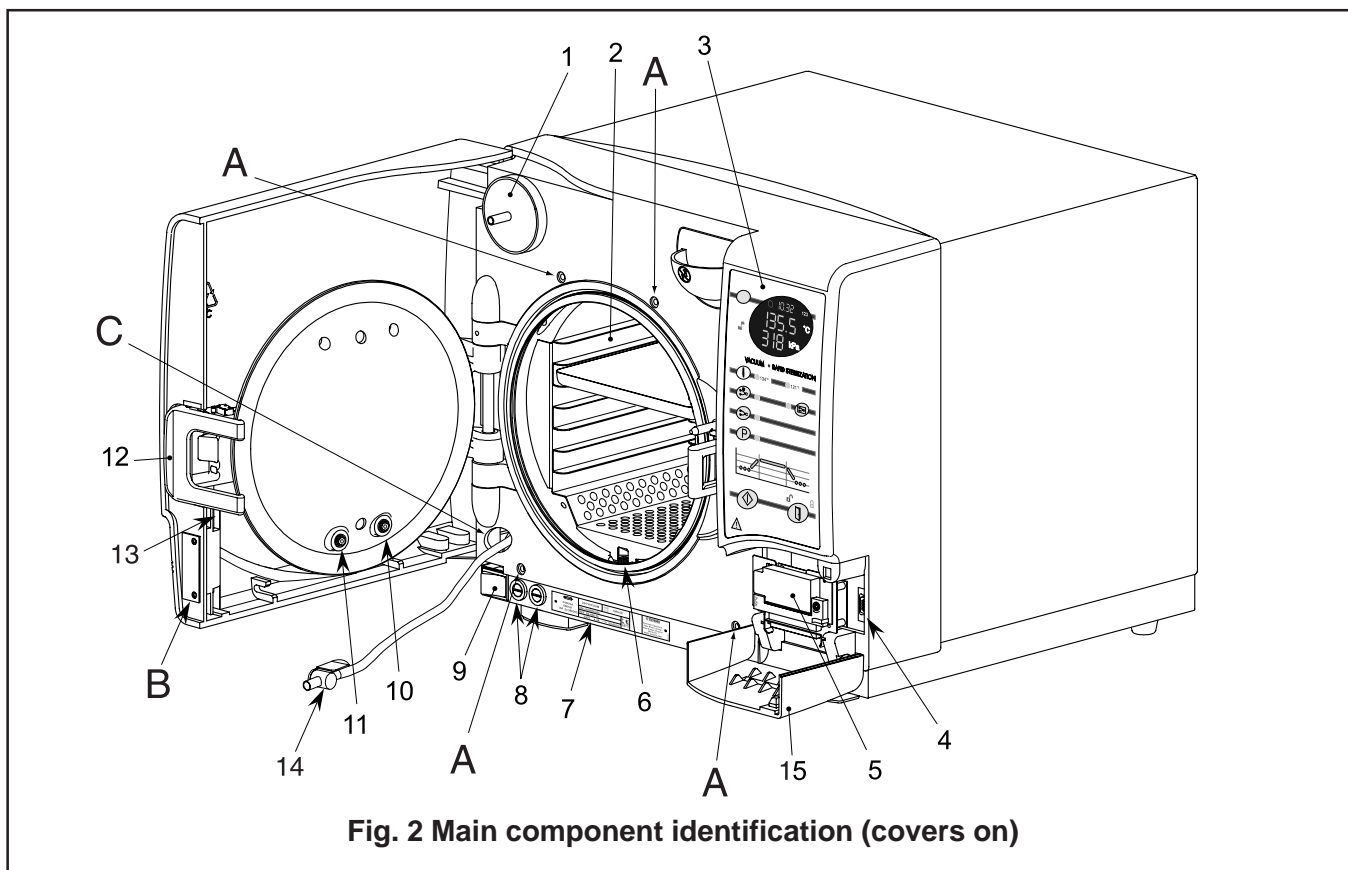


**Fig. 1a Control panel for SES2555 and LS5**



**Fig. 1b Control panel for QuickVac and later SES2555 Models**





**Fig. 2 Main component identification (covers on)**

Door open solenoid, Fig.3 item 6. This is operated when the door open button B7 is pressed to release the primary door lock, or the controller signals it to open the door onto the secondary catch during drying on non-vacuum autoclaves.

Secondary catch, Fig.2 item 12. To ensure that the door does not fly open should there be residual pressure in the chamber when the open door button is operated.

Primary door lock, Fig.3 item 12. Used to lock the door shut during all cycles, cannot be released until Pressure door lock (Fig.3 item 34) opens when pressure falls below 0.2Bar(Gauge).

Door closed microswitch, Fig.3, item 19. This is used to signal the controller that the door is properly closed. It should operate just as the door is fully closed.

Door locked microswitch, Fig. 3, item 18. This is used to signal the controller that the door is properly locked. It should operate just as the door is fully locked.

Chamber pressure gauge, Fig.3 item 21. Fitted behind the door cover, it indicates the approximate chamber pressure (without electrical power).

Water reservoir, Fig.3 item 5. This is used to hold water which is admitted into the chamber via the water fill valve (Fig.3, item 11). The water reservoir also receives hot water and steam vapour discharged from the chamber towards the end of the cycle, via the water discharge valve (Fig.3, item 16). The vacuum pump (Fig.3, item 9) on vacuum units also discharges into the water reservoir.

Reservoir water level sensor (fitted in base of reservoir position indicated in Fig. 4 item 1). The water level sensor in the reservoir will stop the cycle being started if there is insufficient water in the reservoir to complete a chamber fill. Indicator **A1** will be illuminated in a low water condition.

Gauze filter, Fig. 2 item 6. This filters the water leaving the chamber (easily removed for cleaning).

Mains switch, Fig. 2 item 9. This switch controls mains power to the autoclave.

Heating element, Fig.3 item 13, and Fig.4 item 4. The heating element consists of a single immersion element inside the chamber. The heating element is controlled by a solid state relay on the Power PCA (Fig.3, item 26) and protected from overheating by a manual reset thermostat (Fig.3, item 25). Refer to TECHNICAL DATA for heater element loading.

Power board, Fig.3 item 26. There are a number of key functions provided by the power board:

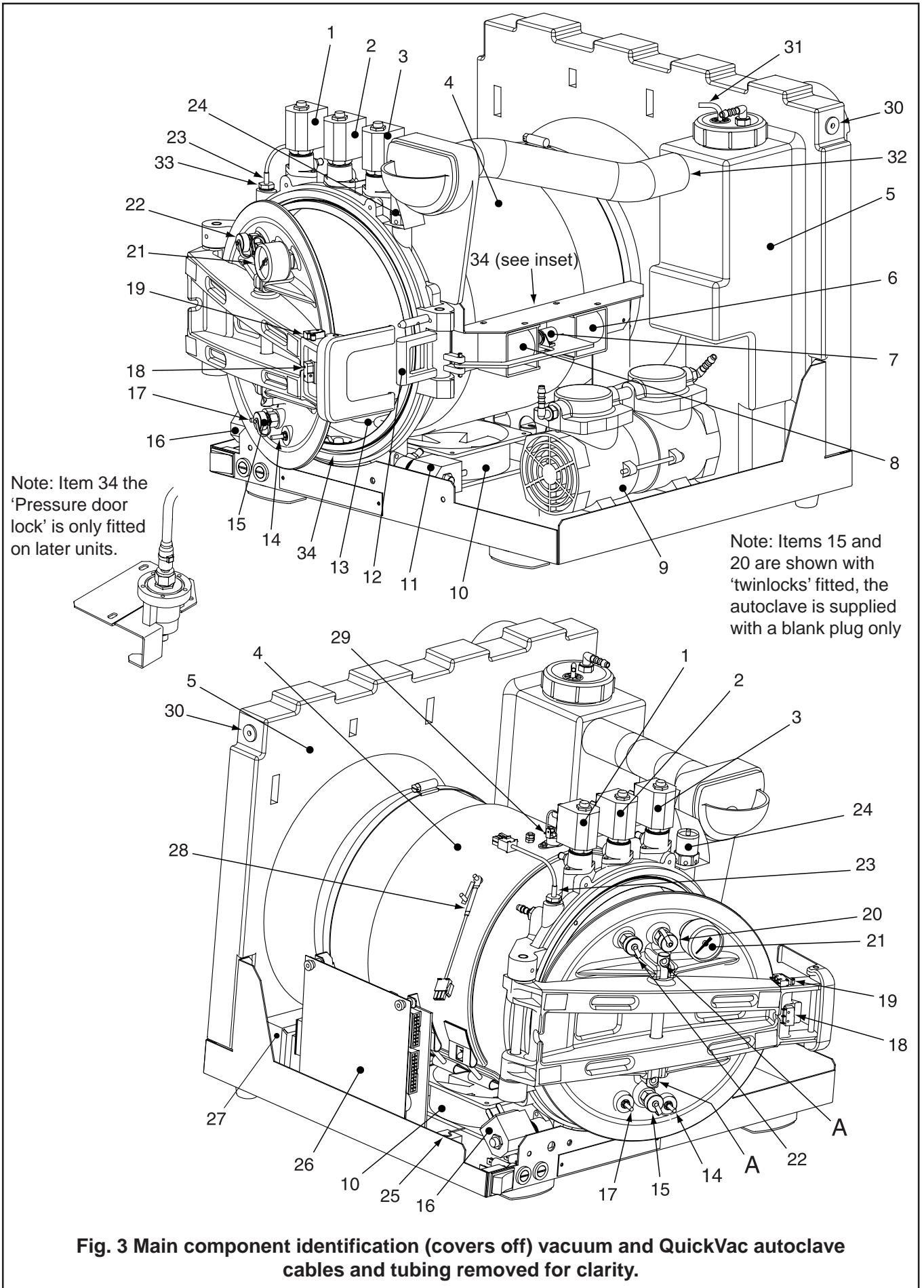
Solid state relays (SSR) control the mains supply to the water heater element (10A), band heater (10A) and vacuum pump (2A).

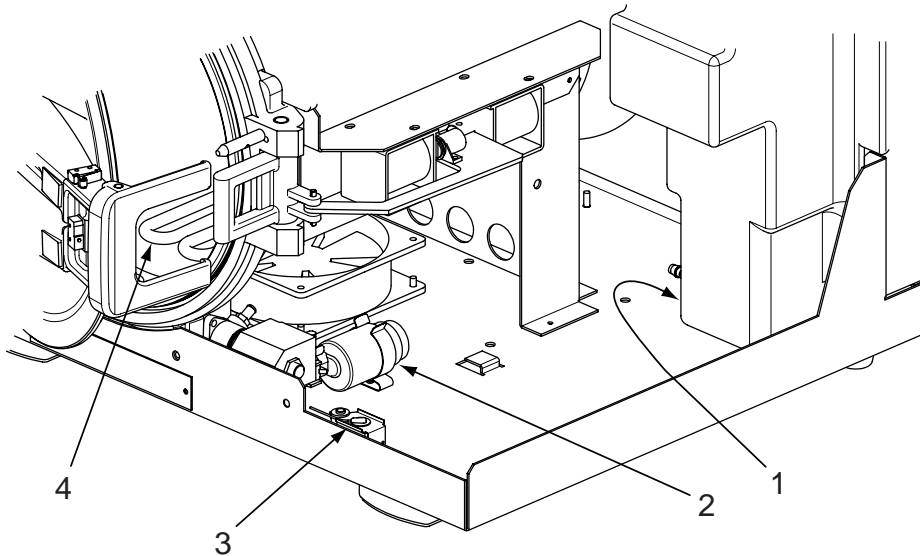
Mechanical relay provides additional safety for heaters and pump circuits.

Connections for display board (40-way ribbon cable, J1), 24 volts from transformer (J2), temperature sensors (J3), solenoid valve drives, door microswitches and water level sensors (J4), mains to heaters and vacuum pump (J5) and mains in (J6).

# LS5/SES2555 & QuickVac

VACUUM & NON-VACUUM AUTOCLAVES





**Fig. 4 Main component identification (covers off) non-vacuum autoclave with cables, pressure door lock and tubing removed for clarity (some parts common to vacuum autoclave).**

Fuse for protecting the 24V d.c. supply (T3.15A).

Two voltage regulators.

Autoclave bleeper.

Pressure transducer with connection via pipe to chamber neck ring.

Display board (fitted behind membrane key pad, Fig.2 item 3). The display board interfaces with the power board to control every aspect of autoclave management. The main features are:

7 segment displays (D1, D2 and D3 of Fig. 1) to provide time, temperature and pressure indication and other information for special and protected functions and error detail.

LEDs to indicate low water, cycle status and door status (A1, A2, A3 and A4 of Fig. 1)

LEDs to provide visual indication of cycle selection (C of Fig. 1).

Connections to Power PCA (40 way ribbon cable, J4), key pad (11 way ribbon cable, J3), printer (16 way ribbon cable, J5) and serial port (10 way ribbon cable, J2).

Battery to maintain real time clock.

Microprocessor to control the autoclave. This receives information from the front panel and all the sensors (temperature, pressure, door microswitches, chamber water level, reservoir level etc.). If any errors are detected they are shown on the display, and printed (if a printer is fitted) as error codes.

Reset thermostat (overheat). Fig.3 item 25. The reset thermostat is fitted underneath the unit and is connected in series with the chamber heater element. The reset thermostat is operated by a fluid-filled capsule clamped to the heating element, providing protection if the temperature of the heater surface exceeds 250°C. It will remake electrically if the reset

button underneath the cabinet is pressed, after giving the heater element time to cool. (Position is indicated by a label on the left-hand side of the unit).

Cycling thermostat, Fig.4 item 3. (Non-vacuum only) This is used to control the temperature of the chamber heating element, in conjunction with the microprocessor, during drying.

Band heater overheat cutout, Fig.3 item 29. (Vacuum units only). The band heater cutout is fitted on the band heater and is connected in series with the band heater. It contains a bimetallic disc thermostat which operates if the temperature of the heater surface exceeds 250°C. The cutout will remake electrically if the reset button is pressed when the heater has cooled.

Mains fuses, Fig. 2 item 8. Two fuses are on the front panel of the unit rated as shown in TECHNICAL DATA, connected in the 'mains supply' to the unit.

Transformer, Fig.3 item 27. The transformer converts the mains voltage to 20V a.c. It is rated at 75VA.

Water fill solenoid valve, Fig.3 item 11. The water fill solenoid valve controls the entry of water into the chamber. It is electrically operated from the 24V d.c. supply generated and signalled from the power board.

Water discharge solenoid valve, Fig.3 item 16. The water discharge solenoid valve is used at the end of the sterilizing cycle to allow water and steam vapour from the chamber to pass back into the reservoir. The valve is electrically operated from a 24V d.c. supply generated and signalled from the power board.

Steam bleed solenoid valve, Fig.3 item 2. The steam bleed solenoid valve is used at the beginning of the heating phase to allow air and steam vapour to pass back into the reservoir, and at the start of discharge to remove



pressure before the discharge valve opens. The valve is electrically operated from a 24V d.c. supply generated and signalled from the power board.

Safety valve, Fig.3 item 24. The safety valve is factory set [pressure rating 2.85Bar (Gauge)] to release excess elevated pressure from within the chamber. It is a primary safety device and must not be readjusted. It should operate between 2.72 and 3.13Bar (Gauge).

Air admit solenoid valve, Fig.3 item 1. (Vacuum units only)  
The air admit solenoid valve controls the admission of air (filtered by the Bacterial Filter, Fig.2 item 1) into the chamber during the drying phase.

Vacuum solenoid valve, Fig.3 item 3. (Vacuum units only)  
When open, this valve allows the vacuum pump to suck air and steam from the chamber. The valve is electrically operated from a 24V d.c. supply generated and signalled from the power board.

Vacuum pump, Fig.3 item 9. (Vacuum units only) The vacuum pump is a two stage diaphragm pump and used to suck air and steam from the chamber. The pump is electrically operated from the mains supply and signalled from the power board.

Bacterial Filter, Fig.2 item 1. (Vacuum units only) The bacterial filter filters the air entering the chamber during the drying phase.

Chamber temperature sensors, Fig.3 item 23. These are used to sense the chamber temperature. Two are provided within the single sensor unit to provide controller accuracy.

Band heater temperature sensor, Fig.3 item 28. (Vacuum units only) The band heater temperature sensor is used to control the band temperature during the drying phase.

Thermocouple entry port, Fig.3 item 22. Marked TT on the chamber door. This is used to insert a thermocouple into the chamber to allow the operating temperature to be measured and, if necessary, adjusted.

Pressure test port, Fig.3 item 15#. Marked PT on the chamber door. The pressure test port is for inserting a pressure probe to monitor chamber pressure.

Spare test port, Fig.3 item 20#. Spare temperature or pressure test port for use as required during test procedures.

Membrane key pad, Fig.2 item 3 & Fig.1a & 1b. Incorporates programme selector buttons, digital display windows and programme indicator LEDs. It is connected to the display board via an 11-way ribbon cable.

Pressure transducer (on the power board). The pressure transducer monitors the pressure in the chamber and generates chamber pressure signals for cycle monitoring, control, and display.

Printer, Fig.2 item 5. The printer, if fitted, starts automatically when a cycle is selected and will print out hardcopy of the sterilization cycle. Details of printer output is given in the 'Instruction for Use'.

Water pump, Fig.4 item 2. (Non-vacuum units only) Used to pump water into the chamber from the reservoir. The pump is operated from a 24V d.c. supply generated and signalled from the power board.

Fan, Fig.3 item 10. The fan draws air over the chamber for rapid cooling between cycles. The fan is electrically operated from the 24V supply and signalled from the power board.

Band heater, Fig.3 item 4. (Vacuum units only) The band heater heats the chamber during the drying cycle. The heating element is controlled by a solid state relay on the Power PCA and protected from overheating by a manual reset thermostat (Fig.3, item 25). Refer to TECHNICAL DATA for heater element loading.

Chamber water level sensors, Fig. 2 items 10 and 11 and Fig.3 items 14 and 17. These signal the power board when the minimum and maximum water levels have been achieved in the chamber during filling. They are connected to the power board.

Thermal fuse, not illustrated, strapped on the outside of the chamber behind neck ring (Non vacuum units only). The thermal fuse is connected in series with the chamber heater element, providing protection if the temperature of the thermal fuse exceeds 184°C (chamber will be above 250°C). It cannot be reset and must be replaced if it trips.

RS232 serial connection port (9-way D type), Fig.2 item 4. This connection port can be used to link the autoclave to a P.C. for calibration, customization, software upgrades, fault diagnosis etc. providing the correct equipment is available (e.g. software).

Magnetic door latch, Fig.3 item 7. (Vacuum units only) Used to hold the primary door lock (Fig.3 item 12) in place during the vacuum cycle.

Pressure door lock, Fig. 3 item 34. This lock stops the door opening when the pressure inside the chamber is above 0.2Bar (Gauge). **Note:** Not fitted on early units.

## 5 Operation cycle

5.1 A detailed knowledge of the operation of the autoclave is not necessary to be able to repair it effectively; however, a basic understanding of the various processes of autoclave operation which occur during a cycle is given in the following paragraphs.

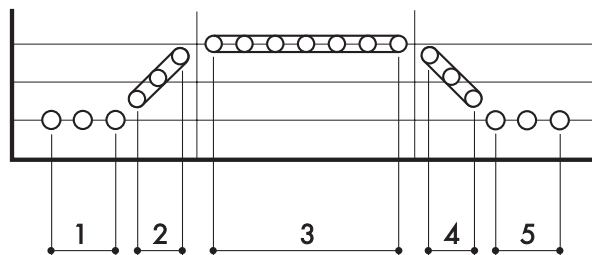
### CAUTION

**Ensure that the Autoclave is switched off before filling the reservoir.**

# Note: Items 15 and 20 are shown with 'twinlocks' fitted, the autoclave is supplied with a blanking plug only

**TABLE 1 - KEY TO DISPLAY A2**

<b>Phase 1</b>	LED 1	Cycle started.
	LED 2	Chamber minimum fill achieved.
	LED 3	Chamber filled with water.
<b>Phase 2</b>	LED 1	Heater on.
	LED 2	Approximately 90°C reached.
	LED 3	Final heating phase started.
<b>Phase 3</b>	LED 1	Sterilization phase started.
	LED 2-7	One sixth of the sterilization time completed for each LED illuminated.
<b>Phase 4</b>	LED 1	Condensing stage started
	LED 2	Water removed from chamber.
	LED 3	Pressure approaching ambient.



<b>Phase 5</b>	LED 1	Start of drying phase.
	LED 2	Drying phase 50% completed.
	LED 3	Cycle completed (audible bleep).

**Note:** Eschmann recommend the use of 'Sterile Water for Irrigation' alternatively clean distilled or deionized water, or water treated by reverse osmosis may be used.

5.2 Power is switched on by selecting the power switch (O-I) to I (Fig.2 item 9).

**NOTE:** If the door was locked closed when switching 'on' indicator **A4** will flash and button **B7** should be pressed to unlock the door, the secondary catch can then be released to open the door fully.

5.3 After loading the chamber close the door and hold it firmly shut until the automatic door lock operates. This is shown by indicator **A3** switching off and indicator **A4** switching on.

**NOTE:** A cycle cannot be selected (as detailed in the 'Instruction for Use') with the door open.

5.4 When the door is closed, with the power switched on, this is sensed by the power board via the door closed microswitch. Indicator **A4** will not illuminate until the automatic lock has operated and the door locked microswitch has been actuated by the primary lock. After cycle selection (as detailed in the 'Instruction for Use') the cycle is started by pressing **B6**. If the autoclave has a printer it will start printing automatically.

5.5 As the cycle progresses indicator **A2** will show the cycle stage reached (see Table 1) and the digital displays **D2** and **D3** will display the actual chamber temperature and pressure respectively.

5.6 Control of the cycle is fully automatic with temperature information being monitored by temperature sensors and displayed on the front panel. Timing is controlled by the power board and cycle times cannot be adjusted. By comparing measured values with known time/temperature relationships, the power board is able to detect faults such as lack of water at the fill stage, or loss of water and steam during the process, and it will indicate such problems by displaying errors codes (e.g. 'Err03') which will be accompanied by an audible warning signal (see Table 4 for details on clearing errors and error codes).

5.7 The autoclave operates at temperatures slightly above the usual recommended minimums. The operating temperature for the 121°C cycle is set to 122.5°C, and the 134°C cycle is set for 135.5°C.

5.8 Operating information relating to the printer is given in the 'Instructions for Use'.

5.9 The overall time for the cycle is not fixed and depends on many factors such as the supply voltage, the load, and the ambient temperature. However, the power board will ensure a satisfactory sterilization cycle even when these factors vary over wide ranges. Typical cycles details are explained in section 6.

## 6 Cycle details

6.1 A typical vacuum cycle (e.g. 134° Wrapped extended cycle) progresses through several stages. The following information provides details of the controls actuated and the resultant functions performed by the autoclave during selection and running of a typical vacuum sterilization cycle.

**Note:** The water reservoir must be above minimum and the door must be closed.

Select temperature 134° with **B2** button. (121° light extinguished, 134° light illuminated or vice versa for each press of button **B2**).

Push **B8** button. (Wrapped LED illuminated, all other cycle LED's extinguished).

Push **B5** button. (Extend LED illuminates, gives sterilization time of 18 minutes at 134°C).

Push **B6** button. (First LED on progress indicator illuminates. If fitted, the printer records time and cycle data. Mains relay is on. Vacuum pump is on. Vacuum inlet valve open. All other valves closed).

Wait for pressure to drop to 32kPa. (Vacuum inlet valve closed. Vacuum pump off. If fitted, the printer outputs 'TPV' followed by the time and temperature and pressure values).

- Programmed pause. (If chamber pressure does not rise by more than 0.9kPa in the last minute, water fill valve opens).
- Wait for water to reach minimum level. (Second LED on progress indicator illuminates).
- Wait for water to reach maximum level. (Water fill valve closes. Third LED on progress indicator illuminates).
- Immersion heater on. (Fourth LED on progress indicator illuminates. Temperature rises).
- Wait for the pressure to rise to 50kPa above atmospheric. (Fifth LED on progress indicator illuminates. Steam bleed valve opens. If fitted, the printer outputs 'TPP' followed by the time and temperature and pressure values).
- Programmed pause. (Steam bleed valve closes. Sixth LED on progress indicator illuminates. Heater off. If pressure above 115kPa, fan on until 115kPa achieved. Fan off, vacuum inlet valve opens and pump starts).
- Wait for pressure to fall 20kPa below atmospheric. (Pump off, vacuum valve closes, heater comes on).
- Wait for temperature to reach 135.0°. (Seventh LED on progress indicator illuminates. If fitted, the printer outputs 'TSS' followed by current time, temperature and pressure values, D1 indicates remaining sterilization time in minutes, initially 18 mins).
- Eighth to thirteenth LED's on progress indicator illuminate at regular intervals. (Temperature should not deviate from 135.5° by more than ±1.5° during sterilisation plateau. If fitted, the printer outputs the temperature and pressure values every 20 seconds. Immersion heater duty drops to approximately 20%).
- Programmed pause. (Immersion heater disabled. Beep sounds. If fitted, the printer outputs 'TSE' followed by the temperature and pressure values. Fan on. Fourteenth LED on progress indicator illuminates. Steam bleed valve pulses to exhaust steam).
- Wait for temperature to drop to 120°C. (Water discharge valve opens. Band heater enabled).
- Wait for the water in the chamber to drain. (Fifteenth LED on progress indicator illuminates).
- Wait for rate of pressure drop below 40kPa/minute. (Sixteenth LED on progress indicator illuminates. Seventeenth LED on progress indicator illuminates. If fitted, the printer outputs 'TDS' followed by the temperature and pressure values. Vacuum pump on. Vacuum inlet valve opens at 115kPa. Beep sounds. D1 displays drying time left).
- Wait for chamber pressure to fall 5kPa below atmospheric. (Air admit valve opens).
- Wait for pressure to return to atmospheric. (Air admit valve closes).
- Wait for 20 seconds. (Air admit valve opens).
- (**Note:** Above two steps repeat until end of drying time)
- Wait for half of specified drying time. (Eighteenth LED on progress indicator illuminates).
- Wait until five minutes before the end of the specified drying time. (Band heater disabled. Fan on).
- Wait until the end of specified drying time. (Nineteenth LED on progress indicator illuminates. Mains relay off. Three beeps sound. If fitted, the printer outputs 'TDE' followed by the temperature and pressure values, 'Cycle Complete' followed by the time. D1 displays time).
- 6.2 A typical non-vacuum cycle (e.g. 134° unwrapped with drying extended cycle) progresses through several stages. The following information provides details of the controls actuated and the resultant functions performed by the autoclave during selection and running of a typical non-vacuum sterilization cycle. **Note:** The water reservoir must be above minimum and the door must be closed.
- Select temperature 134° with **B2** button. (121° light extinguished, 134° light illuminated or vice versa for each press of button **B2**).
- Push **B3** button. (With drying LED illuminated, all other cycle LED's extinguished).
- Push the button **B5**. (Extend LED illuminated, gives sterilization time of 18 minutes at 134°C).
- Push the button **B6**. (First LED on progress indicator illuminates. If fitted, the printer records time and cycle data. Water pump is on. Water fill valve opens. Steam bleed valve opens. All other valves are closed).
- Wait for water to reach minimum level. (Second LED on progress indicator illuminates).
- Wait for water to reach maximum level. (Water fill valve closes. Water pump is off. Third LED on progress indicator illuminates).
- Mains relay on. (Immersion heater on. Fourth LED on progress indicator illuminates. Temperature rises).
- Wait for the temperature to be above 90° and to rise at over 1.8°/minute. (Fifth LED on progress indicator illuminates).
- Programmed pause and condition check. (Steam bleed valve closed. Sixth LED on progress indicator illuminates).
- Wait for temperature to reach 135.0°. (Seventh LED on progress indicator illuminates. If fitted, the printer outputs 'TSS' followed by the current time and the temperature and pressure values. Immersion heater duty drops. Temperature should not deviate from 135.5° by more than ±1.5° during sterilisation plateau. Eighth to thirteenth LED's on progress

indicator illuminate at regular intervals. If fitted, the printer outputs the temperature and pressure values every 20 seconds. D1 indicates remaining sterilization time, initially 18 mins).

Programmed pause. (Immersion heater disabled. Beep sounds. If fitted, the printer outputs 'TSE' followed by the temperature and pressure values, and maximum and minimum sterilization temperatures).

Fan on. (Fourteenth LED on progress indicator illuminates. Steam bleed valve pulses to exhaust steam).

Wait for temperature to drop to 120°C. (Water discharge valve opens).

Wait for the water in the chamber to drain. (Chamber minimum indicator off. Fifteenth LED on progress indicator illuminates).

Wait for rate of pressure drop to go below 60kPa/minute. (Sixteenth LED on progress indicator illuminates. Seventeenth LED on progress indicator illuminates. Fan off at 115kPa. Door catch releases and door is opened by residual pressure. Beep sounds. D1 displays remaining drying time).

Immersion heater duty to 4%. (Steam bleed valve opens. If fitted, the printer outputs 'TDS' followed by the temperature and pressure values. D1 displays drying time left).

Wait for half of specified drying time. (Eighteenth LED on progress indicator illuminates).

Wait for second half of specified drying time. (Nineteenth LED on progress indicator illuminates. Immersion heater disabled. Mains relay off. Fan on. Three beeps sound. If fitted, the printer outputs 'TDE' followed by the temperature and pressure values, 'Cycle Complete' followed by the time. D1 displays time).

## 7 Maintenance

For easy reference to the buttons, display and indicator numbers (**B1**, **D1**, **A1**, etc.) used within the following sections note that Figs. 1a and 1b are repeated on a fold out page at the back of this manual. Open out this page to provide a quick reference guide.

### 7.1 Special functions.

Switch 'off' the mains switch (item 9, Fig.2). Press and hold in the 'P' button **B5** whilst switching the mains switch back 'on' (display **D1** will show **F0**) to make available several special functions as detailed in Table 2 - Special functions. When the autoclave is switched on in this way display **D1** only will be illuminated (with other displays as required depending on which function is selected). Initially

display **D1** will show **F0**, each time the 'P' button **B5** is pressed, this will increase from **F0** up to **F8\*** (**F4**, **F5**, **F6** vacuum autoclave only), and then back to **F0** again, until either the start button **B6** is pressed to select that function, or, the autoclave is switched 'off' or **B7** is pressed (with the door open) to cancel special function selection. To access **F0** the autoclave PIN number (password) is required. If this is known the protected functions are available and are detailed in Table 3 - protected functions.

\* Door must be shut before access to F4, F5, F6 and F7 is permitted.

### 7.2 Protected functions.

Protected functions are accessed through special function **F0** (see above) using the autoclave PIN number (password). If this is known the protected functions are available as detailed in Table 3 - protected functions. When access to the protected functions has been made all displays and indicators are blank except **D1** which shows **P0**. For each press of **B5** the "P" number will increase by 1 and then back to **P0**. Cycle to the number required and press button **B6** to perform that function as detailed in Table 3.

### 7.3 Errors and faults.

#### 7.3.1 Power failure

If, after switching 'on' power there is no visual display, first check power supply connections, both fuses at the front of the unit (see Fuse Renewal) and the fuse in the mains plug (if it is a fused plug). If power fails during a cycle, check supply conditions and fuses at the front of the unit and in the mains plug if fused, also check the mains lead is correctly connected at both ends. Once power is restored the display **D1** will show the error number (**D2** and **D3** will be blank) until cleared by switching the autoclave 'off' and then 'on' whilst depressing the start button **B6**.

#### 7.3.2 Aborted cycles and errors

If an error occurs during a cycle (i.e. any time after pressing the start button **B6**), the cycle will abort and provided power supply to the unit is maintained, the error number will be indicated by the visual display **D1** (displays **D2** and **D3** will continue to show actual temperature and pressure). To display the last error number in display **D1** press **B1** and **B5** together at any time. Errors are detailed in Table 4 - Fault diagnosis with error number details.

#### 7.3.3 Reset thermostat (overheat)

Some solutions to an error number will indicate that the manual reset thermostat may have tripped and caused the error. Should the heating element manual reset thermostat operate this can be reset by pressing the 'reset button' on the underside of the autoclave (approximately 11cm in on the left hand side underneath the unit as indicated on the left hand side of the unit).



### **7.4 Calibration.**

The autoclave can be calibrated by running the calibration cycles (Protected functions P3, P4 and P5 consecutively) This will require the positioning of probes (from calibrated instruments or chart recorders) into the autoclave chamber through the test ports. The three available test ports are positioned in the autoclave door, one marked TT (a twinlock) for the chamber test probe, one marked PT (a blank plug) for the chamber pressure probe and a spare blank plug for probes that could be positioned in the load should this be required. To insert a probe remove the port cover and carefully insert **ROUNDED** tipped probes into the chamber through the seal built into the port, take care not to damage the port seals and replace the cover after use. During calibration of the band heater a temperature probe should be placed under the spring clip provided on the heater, this will require the top cover to be removed to gain access. It is important that the top cover is replaced for accurate calibration.

Running protected function P5 will enable chamber temperature and pressure calibration, band heater calibration and a pressure relief valve test. The latter can be avoided if this test is not required during calibration.

### **7.5 LED Function test.**

To test the function of all LEDs (i.e. to check that they are capable of illumination) press and hold buttons **B6** and **B7** together with the door **open**. All LEDs will be illuminated while the buttons are held depressed together.

### **7.6 Connections, air, water and electrical.**

During maintenance refer to Figs. 5, 10 and 11 for details on all autoclave connections. Fig. 5 shows all the air and water connections whilst Figs. 10 and 11 show the electrical connections for the non-vacuum and vacuum units respectively. (Note: Figs. 10 and 11 open out at the back of this manual). When refitting tie wraps to pipes, use 'Tie wrap tool 5401' set at tension 2.

### **7.7 Safety Checks**

The following safety checks, detailed in the 'Instructions for Use', are repeated here as they are important.

Operators should ensure that the following safety checks are carried out.

#### **Weekly**

- i Check that the door opens and closes easily.
- ii Check the door seal for any signs of damage.
- iii Check the secondary door catch latches effectively.
- iv Check for any obvious escape of steam or water during a cycle (apart from the normal escape via reservoir vents).

Any of the above defects should be attended to by a 'Competent Person' immediately and the autoclave should not be used until repair has been effected (see note below).

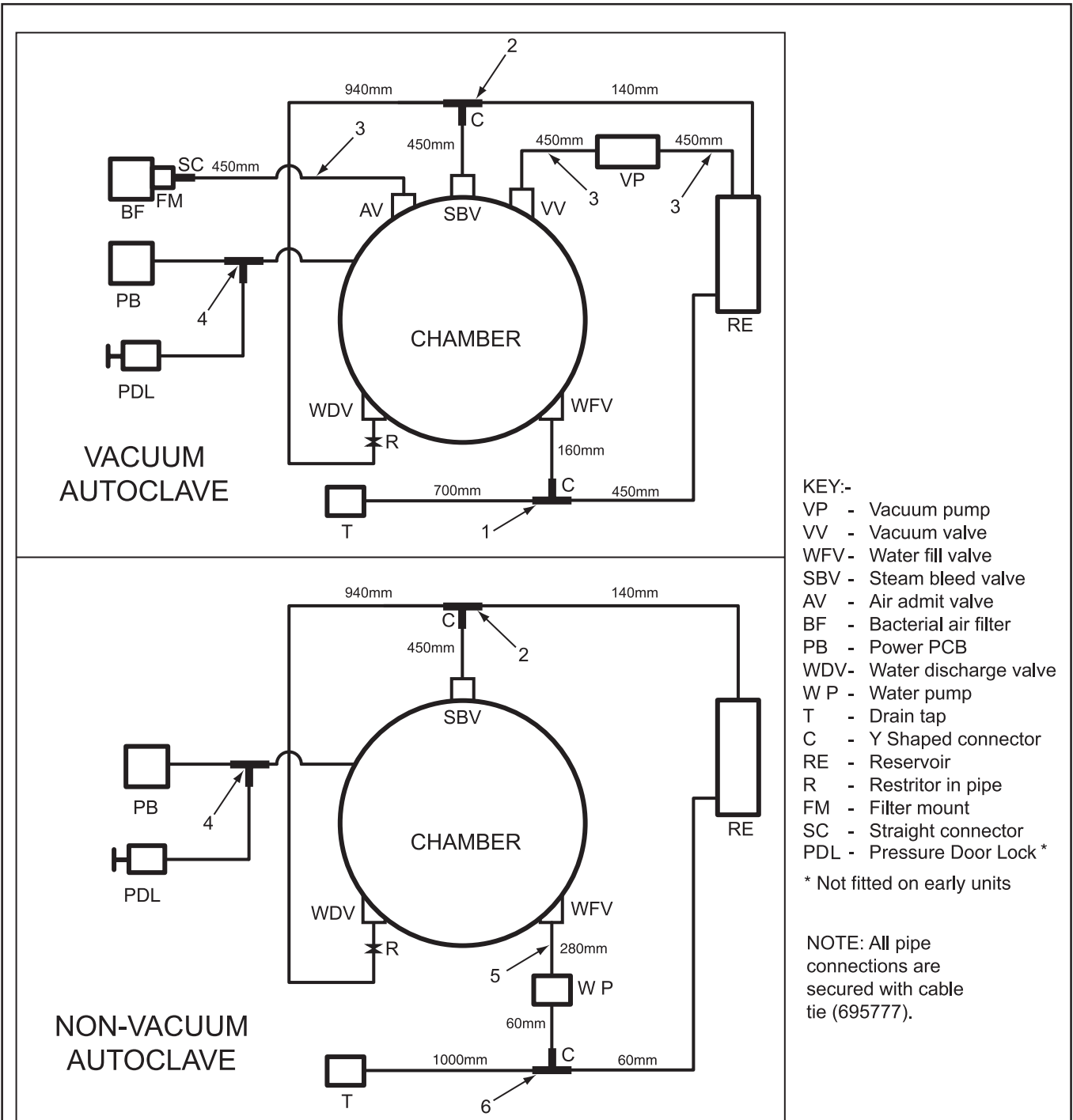
#### **Annually**

- i Check that the pressure relief valve operates correctly at the set pressure.
- ii Inspect the pressure system for integrity.
- iii Check door microswitches and interlocks.
- iv Check door locking mechanism for integrity
- v Check pressure indicators for correct operation.

#### **NOTE:**

Annual inspections should only be undertaken by a 'Competent Person'. Eschmann can provide comprehensive service contracts which cover preventive maintenance to ensure trouble free operation of your autoclave as well as six monthly and annual inspections of the pressure system to satisfy the requirements of the Pressure Systems Safety Regulations 2000.





**KEY:-**  
 VP - Vacuum pump  
 VV - Vacuum valve  
 WFV - Water fill valve  
 SBV - Steam bleed valve  
 AV - Air admit valve  
 BF - Bacterial air filter  
 PB - Power PCB  
 WDV - Water discharge valve  
 W P - Water pump  
 T - Drain tap  
 C - Y Shaped connector  
 RE - Reservoir  
 R - Restrictor in pipe  
 FM - Filter mount  
 SC - Straight connector  
 PDL - Pressure Door Lock \*  
 \* Not fitted on early units

**NOTE:** All pipe connections are secured with cable tie (695777).

**PART IDENTIFICATION:-**  
 1 - Fill/empty pipe assembly (391169) includes spiral wrap (391190)  
 2 - Discharge/air bleed pipe assembly (391168)  
 3 - 450mm pipes (391172)  
 4 - Pipe set, Pressure Door lock (111805)  
 or 400mm pipe (391170) if pressure door lock not fitted  
 5 - 160mm pipe (391171)  
 6 - Fill/empty pipe assembly (111011) includes spiral wrap (391190)  
 All pipes (5mm i.d. x 2mm wall) except 391170 (3mm i.d. x 2mm wall).

**Fig. 5 Pipe connections and identification**

**TABLE 2 - SPECIAL FUNCTIONS** (See section 7.1 which provides instructions for accessing these special functions and Fig. 1a & 1b foldout, at the back of this manual)

DISPLAY	FUNCTION	METHOD OF USE
<b>F0</b>	Protected functions	To use protected <b>P</b> functions requires knowledge of the PIN code (code is in HEX format). With display <b>D1</b> showing <b>F0</b> press the start button <b>B6</b> , display <b>D1</b> shows <b>0</b> . Use <b>B2</b> and <b>B3</b> to adjust <b>D1</b> to show the first digit of the PIN number, then press <b>B4</b> to confirm it. <b>D1</b> will show a <b>0</b> in the next position of the PIN number, use <b>B2</b> , <b>B3</b> and <b>B4</b> to adjust and confirm the second digit. Continue until all digits have been entered, <b>D1</b> will show <b>P0</b> . Press button <b>B5</b> to cycle through the protected functions <b>P0-P9</b> . Use the information in Table 3 - Protected Functions to carry out the selected <b>P</b> function and return the autoclave to normal operation mode.
<b>F1</b>	Printer test	(Note: The printer should be loaded with paper before entering this special functions mode). With display <b>D1</b> showing <b>F1</b> press the start button <b>B6</b> to start the printer test, a character set printout, display <b>D1</b> shows <b>F11</b> . To stop the test press button <b>B7</b> , the printer will stop at the end of the test cycle, display <b>D1</b> shows <b>F0</b> . To resume normal use switch 'off' the mains switch (item 9, Fig. 2) and then switch back 'on', or press <b>B7</b> with the door open.
<b>F2</b>	Cycle history	With display <b>D1</b> showing <b>F2</b> press the start button <b>B6</b> to start printing a summary of the last five cycles completed by the unit (cycle temperature, cycle type, cycle count, date and time at start of cycle, date and time at end of cycle and the cycle result). Display <b>D1</b> returns to <b>F0</b> . To resume normal use switch 'off' the mains switch (item 9, Fig. 2) and then switch back 'on', or press <b>B7</b> with the door open.
<b>F3</b>	Set delayed start	With display <b>D1</b> showing <b>F3</b> press the start button <b>B6</b> to enter the delayed start time setting mode and delayed start initiation, display <b>D1</b> will show <i>Hour</i> . If the start hour displayed in <b>D2</b> is correct (as set last time) and the minutes can be assumed correct (as set last time) press the start button <b>B6</b> to programme the autoclave to start automatically at this set time. The display <b>D1</b> will change to <b>F0</b> when <b>B6</b> is pressed. Press <b>B7</b> with the door open to exit the setting mode. If the start time is not correct when entering function <b>F3</b> (display <b>D1</b> showing <i>Hour</i> , display <b>D2</b> showing the hour set in 24 hour clock mode) press <b>B2</b> to increase the hour (or <b>B3</b> to reduce it). Press <b>B4</b> to confirm the hour when it is correct. Display <b>D1</b> will show <i>Minute</i> , to increase the minutes (shown in <b>D2</b> ) press <b>B2</b> , or <b>B3</b> to reduce them. Press <b>B6</b> to confirm the minutes. The display <b>D1</b> will show <b>F0</b> . Press <b>B7</b> with the door open to exit the setting mode. The autoclave should be left switched 'on' with the required load in place, the door shut and the required cycle selected as follows. When the door is shut a 'E' flashes 'on and off' after the time in display <b>D1</b> . This continues while the program selection and any adjustments to it are made (see 'Instructions for Use' if 'SE' appears in display <b>D2</b> ). When cycle selection has been completed and <b>B6</b> is pressed to confirm them, the 'E' stops flashing. The cycle selected will be run automatically, starting at the time set, a 'E' will be displayed in <b>D1</b> after the time to show that a delayed start time has been set. On completion of the cycle the autoclave is ready for the load to be removed and normal use resumed without the need to exit from the special functions mode. <b>Note:</b> If the same delayed start time is required each day the setting can be entered quickly once display <b>D1</b> shows <b>F3</b> , by pressing ( <b>B6 B6 B7</b> ).
<b>F4</b>	Leak Test <b>(Vacuum Autoclave ONLY)</b> <b>Note.</b> To conduct this test the chamber temperature must be below 50°C to avoid an Error 38, and the door closed before selecting F4.	With display <b>D1</b> showing <b>F0</b> close the autoclave door (if open), press <b>B5</b> until display <b>D1</b> shows <b>F4</b> , press <b>B6</b> . Indicator <b>A4</b> will flash, press <b>B7</b> to open the door, indicator <b>A3</b> will illuminate. Close the door, <b>A4</b> will illuminate, press <b>B6</b> this starts an automatic leak test which checks to see if the autoclave system is still pressure tight. Display <b>D3</b> will show the chamber pressure, after a few minutes display <b>D2</b> will show the pressure rise to the nearest 0.1kPa. After a further 10 minutes if the pressure has not risen by more than 1.3kPa display <b>D2</b> will show <i>PASS</i> indicating the autoclave has passed the test (or <i>FAIL</i> to indicate the autoclave has failed the test) and an audible sound will be heard. (continues on page 16)

**TABLE 2 (continued) - SPECIAL FUNCTIONS**

DISPLAY	FUNCTION	METHOD OF USE
F4 (continued from page 15)		Press button <b>B5</b> and wait until display <b>D2</b> and <b>D3</b> go blank. To resume normal use switch 'off' the mains switch (item 10, Fig. 2) and then switch back 'on', or press <b>B7</b> with the door open.
<b>F5</b>	<b>Air Detection Test (Vacuum Autoclave ONLY)</b> <b>Note.</b> To conduct this test the chamber temperature must be below 50°C to avoid an Error 38, and the door closed before selecting F5. Connect a needle valve (calibrated to provide a leak of between 1.0 and 1.3kPa per minute) via a short length of 6mm hose to the antibacterial filter before pressing <b>B6</b> .	With display <b>D1</b> showing <b>F0</b> close the autoclave door (if open), press <b>B5</b> until display <b>D1</b> shows <b>F5</b> , press <b>B6</b> . Indicator <b>A4</b> will flash, press <b>B7</b> to open the door, indicator <b>A3</b> will illuminate. Close the door, <b>A4</b> will illuminate, press start button <b>B6</b> . This starts an automatic air detection test which checks if the autoclave system detects a leak if present (it performs a leak test similar to F4 first, to ensure no leaks are present, then admits air through the needle valve). Display <b>D3</b> shows chamber pressure, after a few minutes display <b>D2</b> will show pressure rise to the nearest 0.1kPa. After a further 10 minutes if pressure has not risen by more than 1.3kPa display. Display <b>D2</b> will then show <i>PASS</i> or <i>FAIL</i> according to result (test aborts on <i>FAIL</i> ). If first test is <i>PASS</i> the air valve will open to conduct detection test. After one minute if pressure <34kPa the leak rate is measured for one minute (if =>34kPa test aborts), display <b>D3</b> will show pressure. If the rate of pressure rise is more than 0.9kPa display <b>D2</b> will show <i>PASS</i> indicating the autoclave has passed the test, or <i>FAIL</i> to indicate the autoclave has failed the test (i.e. pressure rise equal or less than 0.9kPa). To resume normal use switch 'off' the mains switch (item 9, Fig. 2) and then switch back 'on', or press <b>B7</b> with the door open.
<b>F6</b>	<b>Steam penetration test. (Vacuum Autoclave ONLY)</b> <b>Note.</b> To conduct this test the door must be closed before selecting F6.	With display <b>D1</b> showing <b>F0</b> close the autoclave door (if open), press <b>B5</b> until display <b>D1</b> shows <b>F6</b> , press <b>B6</b> . Indicator <b>A4</b> will flash, press <b>B7</b> to open the door, indicator <b>A3</b> will illuminate. Place the Eschmann LS5 Vacuum Type-S and QuickVac Steam Penetration Test Device in it's pouch (see test device instructions for use) and into the chamber. Close the door, <b>A4</b> will illuminate, press the start button <b>B6</b> , this will start a special <b>B8</b> cycle (no drying), <b>D2</b> and <b>D3</b> will show temperature and pressure as normal during the cycle. At the end of the cycle the normal audible sound will be heard. Press <b>B7</b> to open the door, display <b>D1</b> will be showing <b>F0</b> . To resume normal use switch 'off' the mains switch (item 9, Fig. 2) and then switch back 'on', or press <b>B7</b> with the door open. (NOTE: This function can also be used to carry out HTM2010 Performance Qualification (PQ) Tests in conjunction with the 'Instructions for Testing' manual ST-IM55).
<b>F7</b>	<b>Disinfect function</b> <b>Note.</b> To conduct this test the door must be closed before selecting F7.	With display <b>D1</b> showing <b>F7</b> load the autoclave with the load to be disinfected and close the door. Press the start button <b>B6</b> to start the disinfect function (a 2.5 minute disinfect time at 110°C), <b>D1</b> will continue to show <b>F7</b> during the cycle and <b>D2</b> and <b>D3</b> will show temperature and pressure. At the end of the cycle the normal audible sound will be heard. Press <b>B7</b> to open the door and remove the load, display <b>D1</b> will be showing <b>F0</b> . To resume normal use switch 'off' the mains switch (item 9, Fig. 2) and then switch back 'on', or press <b>B7</b> with the door open. (NOTE: The ex-factory condition is for this function to be disabled.)
<b>F8</b>	<b>Adjust date and time</b>	With display <b>D1</b> showing <b>F8</b> press the start button <b>B6</b> to enter the adjust date and time function. Display <b>D1</b> will show <i>YEAR</i> and <b>D2</b> will show the year, to increase the year press <b>B2</b> (or <b>B3</b> to reduce it) when correct press button <b>B4</b> to confirm the year. The display <b>D1</b> will show <i>MONTH</i> and <b>D2</b> will show the month in numerical format, to increase the month press <b>B2</b> (or <b>B3</b> to reduce it) when correct press button <b>B4</b> to confirm. The display <b>D1</b> will show <i>DAY</i> and <b>D2</b> will show the day in numerical format, to increase the day press <b>B2</b> (or <b>B3</b> to reduce it) when correct press button <b>B4</b> to confirm. The display <b>D1</b> will show <i>Hour</i> and <b>D2</b> will show the hour, to increase the hour press <b>B2</b> (or <b>B3</b> to reduce it) when correct press button <b>B4</b> to confirm. The display <b>D1</b> will show <i>Minute</i> and <b>D2</b> will show the minute, to increase the minute press <b>B2</b> (or <b>B3</b> to reduce it) when correct press button <b>B6</b> , display <b>D1</b> shows <b>F0</b> display <b>D2</b> and <b>D3</b> will be blank. The time and date are now set (seconds were set to zero when <b>B6</b> was pressed). Press <b>B7</b> with the door open to continue normal use.

**TABLE 3 - PROTECTED FUNCTIONS** (See section 7.2 which provides instructions for accessing these special functions and Fig. 1a & 1b foldout, at the back of this manual)

DISPLAY AND FUNCTION	METHOD OF USE
<b>P0 - Print last 5 failed cycles</b>	<p>This protected function prints a summary of the last five failed cycles. Display <b>D1</b> shows <b>P0</b>. Press button <b>B6</b>. The printer prints a summary of the last five failed cycles containing the following information for each cycle; Cycle temperature, Cycle type, the word "Extended" if the cycle was extended, Cycle count, Date and time at start of cycle, Date and time at end of cycle and the word "Error" followed by the error number. Display shows <b>F0</b>. With the door open press <b>B7</b> to exit back to normal mode, or <b>B5</b> to cycle through and gain access to other protected functions (by pressing <b>B6</b> when the correct <b>P</b> number is displayed).</p>
<b>P1 - Print last failed cycle</b>	<p>This protected function prints a summary of the last failed cycle. Display <b>D1</b> shows <b>P1</b>. Press the button <b>B6</b>. The printer prints a summary of the last failed cycle, containing the following information; Cycle temperature, Cycle type, the word "Extended" if the cycle was extended, Cycle count, Date and time at start of cycle, Date and time at end of cycle, the word "Error" followed by the error number and up to nineteen lines containing the time, temperature and pressure. Display shows <b>P1</b>. With the door open press <b>B7</b> to exit back to special function <b>F0</b>, or <b>B5</b> to cycle through and gain access to other protected functions (by pressing <b>B6</b> when the correct <b>P</b> number is displayed).</p>
<b>P2 - Recall factory calibration</b>	<p>This protected function recalls and copies the factory calibration to the field calibration area. Display <b>D1</b> shows <b>P2</b>. Press button <b>B6</b>, display <b>D1</b> shows <b>P21</b>. Press and hold <b>B3</b> and <b>B5</b> buttons together until a beep is heard. The factory calibration information overwrites the current field calibration. Display <b>D1</b> shows <b>P2</b>. With the door open press <b>B7</b> to exit back to special function <b>F0</b>, or <b>B5</b> to cycle through and gain access to other protected functions (by pressing <b>B6</b> when the correct <b>P</b> number is displayed). <b>Always</b> recalibrate after using this function, see section 7.4.</p>
<b>P3 - Room Temperature Calibration</b>	<p>This protected function performs a room temperature calibration. Ensure autoclave is at room temperature before starting to eliminate calibration errors. Insert the required probes from the calibrated instruments and/or chart recorders (e.g. chamber temperature probe, chamber pressure probe) as detailed in section 7.4. <b>Replace the autoclave cover during calibration.</b> The door <b>must be open</b> and on the secondary catch for this protected function. Display <b>D1</b> shows <b>P3</b>, press button <b>B6</b>, display <b>D1</b> shows "t" followed by the current temperature. Display <b>D2</b> shows the current temperature, display <b>D3</b> shows the current pressure in kPa. Use buttons <b>B2</b> and <b>B3</b> to set the value in display <b>D1</b> to the current temperature indicated on the calibrated instrument. Press button <b>B6</b> until a beep is heard. Press button <b>B1</b>, display <b>D1</b> shows "P" followed by the current pressure in mBars. Use buttons <b>B2</b> and <b>B3</b> to set the value in display <b>D1</b> to the current pressure indicated on the calibrated instrument. (Note: The value in display <b>D1</b> changes in steps of 2 mBars). Press button <b>B6</b> until a beep is heard and the temperature and pressure displays change to the values entered in the previous steps. Press button <b>B7</b>, display <b>D1</b> shows <b>P3</b>. With the door open press <b>B7</b> to exit back to special function <b>F0</b>, or <b>B5</b> to cycle through and gain access to other protected functions (by pressing <b>B6</b> when the correct <b>P</b> number is displayed).</p>
<b>P4 - Low pressure calibration</b>	<p>This protected function performs a low-pressure calibration. <b>This function can only be run on a vacuum autoclave.</b> The door must be <b>closed</b> for this protected function. Insert a suitable pressure probe from a calibrated instrument and/or chart recorder as detailed in section 7.4. Display <b>D1</b> shows <b>P4</b>, press button <b>B6</b>. Display <b>D1</b> shows <b>P 200</b>, display <b>D3</b> shows the current pressure in kPa. (<b>Note:</b> D3 pressure is always in kPa). Wait until the pressure drops to about 200 mBars on the calibrated instrument then press button <b>B5</b> (this closes the vacuum solenoid valve, but leaves the pump running). Use buttons <b>B2</b> and <b>B3</b> to set the value in display <b>D1</b> to the current</p>

(Continued on page 18)

**TABLE 3 (continued) - PROTECTED FUNCTIONS**

DISPLAY AND FUNCTION	METHOD OF USE
	<p>pressure indicated on the calibrated instrument. (<b>Note:</b> The pump is running during this calibration and the vacuum solenoid valve can be toggled open and closed by pressing <b>B5</b>, this enables chamber pressure to be adjusted if required). Press button <b>B6</b> until a beep is heard to save calibration data . Press button <b>B7</b>, wait for the pressure to return to within 5 mBars of atmospheric. Display <b>D1</b> shows <b>P4</b>. With the door open press <b>B7</b> to exit back to special function <b>F0</b>, or <b>B5</b> to cycle through and gain access to other protected functions (by pressing <b>B6</b> when the correct <b>P</b> number is displayed).</p>
<p><b>P5 - Low and high temperature calibration</b></p>	<p>Insert the required probes from the calibrated instruments and/ or chart recorders (e.g. chamber temperature probe, chamber pressure probe and band heater probe) as detailed in section 7.4. <b>Replace the autoclave cover during calibration.</b> The door <b>must</b> be <b>closed</b> for this protected function. Display <b>D1</b> shows <b>P5</b>, press button <b>B6</b>.</p> <p>For <b>Non-Vacuum</b> - A 121°C Naked without Drying cycle is started.</p> <p>For <b>Vacuum</b> - A 121°C Naked with Drying cycle is started.</p> <p>(<b>Note:</b> For both the above cycles the sterilisation time is extended to give adequate time to achieve an accurate calibration).</p> <p>Button <b>B5</b> LED is illuminated and (if fitted) the printer records time and cycle data with the words “Calibration Cycle” after the cycle type. Wait for the sterilisation plateau to be reached, then press button <b>B1</b>. Display <b>D1</b> shows “t” followed by the current temperature. Use buttons <b>B2</b> and <b>B3</b> to set the value in display <b>D1</b> to the current temperature indicated on the calibrated instrument. Continue to adjust the temperature in <b>D1</b> until a stable condition is achieved. (<b>Note:</b> The sterilisation time can be extended if required by pressing <b>B5</b>). Press button <b>B4</b> until a beep is heard. Display <b>D1</b> shows the new temperature value. Press button <b>B1</b>, display <b>D1</b> shows “P” followed by an estimated pressure value based on the current temperature. Use buttons <b>B2</b> and <b>B3</b> to set the value in display <b>D1</b> to the current pressure indicated on the calibrated instrument (the value in display <b>D1</b> changes in steps of 2). Press button <b>B4</b> until beep is heard. Display <b>D3</b> shows the new pressure value. Press and hold buttons <b>B2</b> and <b>B6</b> until beep is heard. The 121° LED is extinguished and the 134° LED is illuminated, the temperature rises towards 135.5°C, process display <b>A2</b> returns to the seventh LED illuminated, display <b>D1</b> shows <b>P5</b>. Wait for the temperature to approach 135.5°C, then press button <b>B1</b>. Display <b>D1</b> shows t followed by the current temperature. Use buttons <b>B2</b> and <b>B3</b> buttons to set the value in display <b>D1</b> to the current temperature indicated on the calibrated instrument. Continue to adjust the temperature in <b>D1</b> until a stable condition is achieved. (<b>Note:</b> The sterilisation time can be extended if required by pressing <b>B5</b>). Press button <b>B4</b> until beep is heard. Display <b>D1</b> shows the new temperature value. Press button <b>B1</b>, display <b>D1</b> shows “P” followed by an estimated pressure value based on the current temperature. Use buttons <b>B2</b> and <b>B3</b> to set the value in display <b>D1</b> to the current pressure indicated on the calibrated instrument. Press button <b>B4</b> until beep is heard. Display <b>D3</b> shows new pressure value.</p> <p>If it is required to test the safety valve press and hold buttons <b>B2</b> and <b>B7</b> until beep is heard, the 121° LED illuminates, the temperature rises towards 148°C (approx.), the process display <b>A2</b> returns to the seventh LED illuminated, display <b>D1</b> shows <b>P5</b>. Wait for the pressure to reach about 385kPa, the safety relief valve starts to release the pressure from the chamber, note valve limits are 2.72 - 3.13Bar (Gauge.)</p> <p>Press and hold buttons <b>B5</b> and <b>B7</b>, the water discharge valve opens, process display <b>A2</b> advances to the fourteenth LED.</p> <p><b>Non-Vacuum</b> - The steriliser completes the cycle normally, display <b>D1</b> shows <b>P5</b> all other displays are blank.</p>

(Continued on page 19)



**TABLE 3 (CONTINUED) - PROTECTED FUNCTIONS**

DISPLAY AND FUNCTION	METHOD OF USE
	<p><b>Vacuum</b> - The steriliser continues onto the drying phase, wait for band heater temperature to reach about 158°C on the calibrated instrument, then press button <b>B1</b>. Display <b>D1</b> shows “t” followed by current band heater temperature. Use buttons <b>B2</b> and <b>B3</b> to set the value in display <b>D1</b> to the current temperature indicated on the calibrated instrument. Continue to adjust the temperature in <b>D1</b> until a stable condition is achieved. Press button <b>B4</b>, a beep is heard. Press and hold button <b>B5</b> and <b>B7</b>, the autoclave completes the cycle immediately. Display <b>D1</b> shows <b>P5</b>, all other displays are blank. With the door open press <b>B7</b> to exit back to special function <b>F0</b>, or <b>B5</b> to cycle through and gain access to other protected functions (by pressing <b>B6</b> when the correct <b>P</b> number is displayed).</p>
<p><b>P6 - Cycle Enable/Disable</b></p>	<p>This protected function enables or disables the sterilization cycles. Display <b>D1</b> shows <b>P6</b>, press button <b>B6</b>. The programme and temperature LEDs display the default programme. All LEDs on the progress indicator <b>A2</b> are illuminated to indicate this programme is enabled. Button <b>B4</b> can now be used to toggle all LEDs on the progress indicator <b>A2</b> “on” or “off” showing that the indicated programme is enabled or disabled respectively.</p> <p>Press button <b>B2</b>, the programme and temperature LEDs display the next programme. Use <b>B4</b> to toggle all LEDs in <b>A2</b> “on” or “off” to enable or disable the indicated programme.</p> <p>Repeat pressing <b>B2</b> and enable or disable each programme as required (when indicated) until all programmes have been set as required. (<b>Note:</b> When <b>B2</b> is pressed and no indicator lights are “on” display <b>D2</b> will show either <i>d /5</i>, to indicate the disinfect cycle, or <i>HOL</i>, to indicate the ‘Hollow Naked’ cycle. These can also be enabled or disabled by pressing button <b>B4</b>. Autoclaves without button <b>B9</b> will still display the option to enable or disable the ‘Hollow Naked’ cycle even though the cycle cannot be run).</p> <p><b>Note:</b> Pressing button <b>B3</b> will enable <b>all</b> programmes, it is <b>not</b> possible to disable all programmes. When button <b>B5</b> indicator illuminates this indicates an extended cycle.</p> <p>Press button <b>B6</b> until a beep is heard, all the programme enabling or disabling settings made above are stored in memory, display <b>D1</b> shows <b>P6</b> all other displays or indicators are “off”. To exit press <b>B7</b> (with the door open) or <b>B5</b> to cycle through and gain access to another protected functions. When the correct <b>P</b> number is displayed by pressing <b>B6</b>.</p>
<p><b>P7 - I/O Test</b></p>	<p>This test verifies all the inputs and outputs to the Microcontroller. When familiar with the use of this protected function, see Table 5 for a quick reference chart which details how to use <b>P7</b> to check individual components, rather than progressing through each one, as detailed below. Before using Table 5 ensure you know how to activate and leave this protected function. The water reservoir should be empty (if not, the 8<sup>th</sup> LED of the progress indicator <b>A2</b> will be “on” throughout this test and it will not be possible to test the reservoir sensor). Display <b>D1</b> shows <b>P7</b>, press button <b>B6</b>. Display <b>D1</b> shows the raw ADC value for the first pressure transducer, display <b>D2</b> shows <b>P1</b>, display <b>D3</b> shows <b>1</b>, the fourth and sixth LEDs on the progress indicator <b>A2</b> are illuminated if the door is open. Press button <b>B1</b>, display <b>D1</b> shows the raw ADC value for the second pressure transducer, display <b>D2</b> shows <b>P2</b>. Press button <b>B1</b>, display <b>D1</b> shows the raw ADC value for the first chamber temperature transducer, display <b>D2</b> shows <b>t1</b>. Press button <b>B1</b>, display <b>D1</b> shows the raw ADC value for the second chamber temperature transducer, display <b>D2</b> shows <b>t2</b>. Press button <b>B1</b>, display <b>D1</b> shows the raw ADC value for the Band Heater temperature transducer, display <b>D2</b> shows <b>t3</b>. Press button <b>B1</b>, display <b>D1</b> shows the raw ADC value for the first pressure transducer, display <b>D2</b> shows <b>P1</b>, display <b>D3</b> shows <b>1</b>.</p> <p>Press button <b>B4</b>, B4 LED illuminates, and the water discharge valve opens. Press button <b>B4</b>, B4 LED goes “off” and the water discharge valve closes.</p> <p style="text-align: right;">(Continued on page 20)</p>

**TABLE 3 (CONTINUED) - PROTECTED FUNCTIONS**

DISPLAY AND FUNCTION	METHOD OF USE
<p><b>P7 - I/O Test</b> (cont'd)</p>	<p>Press button <b>B2</b>, display <b>D3</b> shows <b>2</b>. Press button <b>B4</b>, B4 LED illuminates, and the water fill valve opens. Press button <b>B4</b>, B4 LED goes "off" and the water fill valve closes.</p> <p>Press button <b>B2</b>, display <b>D3</b> shows <b>3</b>. Press button <b>B4</b>, B4 LED illuminates, and the air admit valve opens. Press button <b>B4</b>, B4 LED goes "off" and the air admit valve closes. (Only on vacuum autoclaves).</p> <p>Press button <b>B2</b>, display <b>D3</b> shows <b>4</b>. Press button <b>B4</b>, B4 LED illuminates, and the fan runs. Press button <b>B4</b>, B4 LED goes "off" and the fan stops.</p> <p>Press button <b>B2</b>, display <b>D3</b> shows <b>5</b>. Press button <b>B4</b>, B4 LED illuminates, and the steam bleed valve opens. Press button <b>B4</b>, B4 LED goes "off" and the steam bleed valve closes.</p> <p>Press button <b>B2</b>, display <b>D3</b> shows <b>6</b>. Press button <b>B4</b>, B4 LED illuminates, and the vacuum inlet valve opens. Press button <b>B4</b>, B4 LED goes "off" and the vacuum inlet valve closes. (Only on vacuum autoclaves).</p> <p>Press button <b>B2</b>, display <b>D3</b> shows <b>7</b>. Press button <b>B4</b>, B4 LED illuminates, and the door open solenoid operates. Press button <b>B4</b>, B4 LED goes "off" and the door open solenoid operates.</p> <p>Press button <b>B2</b>, display <b>D3</b> shows <b>8</b>. Press button <b>B4</b>, B4 LED illuminates, and the door close solenoid operates. Press button <b>B4</b>, B4 LED goes "off" and the door close solenoid operates.</p> <p>Press button <b>B2</b>, display <b>D3</b> shows <b>9</b>. Press button <b>B4</b>, B4 LED illuminates, and the mains relay is "on". Press button <b>B4</b>, B4 LED goes "off" and the mains relay is "off". Press button <b>B4</b>, to turn the mains relay "on" and leave it "on" to enable other tests (e.g. heaters) that follow.</p> <p>Press button <b>B2</b>, display <b>D3</b> shows <b>10</b>. Press button <b>B4</b>, B4 LED illuminates, and the water pump operates. Press button <b>B4</b>, B4 LED goes "off" and the water pump stops. (Only on non-vacuum autoclaves).</p> <p>Press button <b>B2</b>, display <b>D3</b> shows <b>11*</b>. Press button <b>B4</b>, B4 LED illuminates, and the vacuum pump operates. Press button <b>B4</b>, B4 LED goes "off" and the vacuum pump stops. (Only on vacuum autoclaves).</p> <p>Press button <b>B2</b>, display <b>D3</b> shows <b>12*</b>. Press button <b>B4</b>, B4 LED illuminates, and the band heater is "on". Press button <b>B4</b>, B4 LED goes "off" and the band heater is "off". (Only on vacuum autoclaves).</p> <p>Press button <b>B2</b>, display <b>D3</b> shows <b>13*</b>. Press button <b>B4</b>, B4 LED illuminates, and the immersion heater is "on". Press button <b>B4</b>, B4 LED goes "off" and the immersion heater is "off".</p> <p>Press button <b>B2</b>, display <b>D3</b> shows <b>14</b>. Press button <b>B4</b>, B4 LED illuminates, and the beeper is "on". Press button <b>B4</b>, B4 LED goes "off" and the beeper is "off".</p> <p>Press button <b>B2</b>, display <b>D3</b> shows <b>1</b>. Press button <b>B4</b>, B4 LED illuminates, and the water discharge valve opens. Press button <b>B3</b>, B4 LED goes "off" and the water discharge valve closes.</p> <p>Short the chamber minimum water level sensor to the door, the second LED on progress indicator <b>A2</b> illuminates.</p>
	<p>(Continued on page 21)</p>
	<p>* Ensure mains relay was left "on" (when <b>D3</b> shows <b>9</b> above) to perform this test.</p>

**TABLE 3 (CONTINUED) - PROTECTED FUNCTIONS** (See section 7.2)

DISPLAY AND FUNCTION	METHOD OF USE
<p><b>P7 - I/O Test</b> (cont'd)</p>	<p>Short the chamber maximum water level sensor to the door, the third LED on progress indicator <b>A2</b> illuminates.</p> <p>Operate the door closed microswitch, the fourth LED on progress indicator <b>A2</b> is extinguished and the fifth LED on progress indicator <b>A2</b> is illuminated.</p> <p>Operate the door locked microswitch, the sixth LED on progress indicator <b>A2</b> is extinguished and the seventh LED on progress indicator <b>A2</b> is illuminated.</p> <p>Short the two reservoir water level sensors together, the eighth LED on progress indicator <b>A2</b> illuminates.</p> <p>Press button <b>B7</b>, display <b>D1</b> shows <b>P7</b>, all other displays are blank.</p> <p>To exit press <b>B7</b> (with the door open) or <b>B5</b> to cycle through and gain access to another protected functions. When the correct <b>P</b> number is displayed by pressing <b>B6</b>.</p>
<p><b>P8 - Service completion</b></p>	<p>When service is carried out in response to a service request from the autoclave, it is necessary to reset the service request flag in the EEPROM. This occurs automatically if the unit is re-calibrated. It can also be done through the protected function <b>P8</b>. Display <b>D1</b> shows <b>P8</b>. Press button <b>B6</b>. The autoclave beeps. The service request is set for 11 months later and will print 'Service and Certification due'. Display <b>D1</b> shows <b>P8</b>.</p> <p>To exit press <b>B7</b> (with the door open) or <b>B5</b> to cycle through and gain access to another protected functions. When the correct <b>P</b> number is displayed by pressing <b>B6</b>.</p>
<p><b>P9 - Enable/disable adjustable drying and sterilization times</b></p>	<p>This function changes the configuration file to disable, or to enable, the facility which allows the user to alter the preset sterilization and drying times when selecting a cycle. Display <b>D1</b> shows <b>P9</b>. Press button <b>B6</b>. <b>D2</b> displays either <i>d 15</i> if the function is disabled or <i>E 1</i> if it is enabled. Press button <b>B2</b> to enable it, or press button <b>B3</b> to disable it. Press button <b>B6</b> to confirm the setting. The autoclave beeps to acknowledge. Display <b>D1</b> shows <b>P9</b>. To exit press <b>B7</b> (with the door open) or <b>B5</b> to cycle through and gain access to another protected functions. When the correct <b>P</b> number is displayed by pressing <b>B6</b>.</p>

**TABLE 4 - FAULT DIAGNOSIS AND ERROR NUMBER DETAILS**

**CLEARING ERROR DISPLAY AND RESTARTING A CYCLE**

**WARNING**

If an error display appears during a cycle, do not attempt to open the chamber door until the unit has cooled (for safety below 50°C) and internal pressure has fallen sufficiently to release the door, see '3 Check pressure'. Loads whose cycles are aborted by one of these error displays should be treated as non-sterile, they should be re-wrapped if wrapped and then sterilized by running the cycle again. Also note the Caution after section 16.1 in the 'Instructions' concerning the contamination of water in the reservoir.

**1 Record error number :** For future reference record the error number before clearing the display. In the event of mains power failure, power must be restored to the autoclave to achieve this.

**2 Clear error and reset autoclave :** To clear the error display and reset the autoclave wait until any audible discharge of water and steam has stopped and switch OFF the autoclave with the mains switch (item 9, Fig. 2). Wait 10 seconds, press-and-hold-in the 'Start button' (B6 Fig.1) whilst switching back ON with the mains switch (item 9, Fig. 2), immediately the normal display appears release the 'Start button' (B6 Fig.1).

**3 Check pressure :** Before attempting to open the door note the pressure reading, this should be below 104kPa before the door is opened.

**4 Open the door :** Note A4 will be flashing, open the door by pressing B7. If the door fails to open see NOTE below, there may still be water in the autoclave.

NOTE: Door opening problems. There may be up to a litre of water (which could be HOT) still in the chamber, be prepared to collect this in a suitable container. A built-in safety feature inhibits door opening unless the following procedure is adopted. Switch OFF at mains switch (item 9, Fig. 2). Press-and-hold-in the 'Door open button' (B7 Fig.1) whilst switching back ON with the mains switch (item 9, Fig. 2) wait two seconds and then **before** releasing button B7 (which will open the door) hold a container in place under the door to collect any (HOT) water.

**5 Check and prepare the aborted load :** Loads must be considered non-sterile if an error occurs and should be re-sterilized. All aborted wrapped loads should be dried, placed in new pouches and reprocessed.

**6 Check chamber before starting another cycle :** The chamber should be allowed to dry and cool before starting another cycle. To start another cycle select the cycle and start the autoclave in the normal manner.

**7** If the error persists or an error number occurs that is listed at the end of this table then call the Eschmann After Sales Service Department (see details inside front cover) or contact your approved service engineer. Do not attempt to solve an error using tools or tampering with the autoclave.

**FAULT DIAGNOSIS**

**Note: Consult Table 3, the protected functions table, section P7. This function will enable each of the main components within the autoclave to be tested by pressing the specified buttons on the control panel thus verifying the inputs and outputs to the microcontroller. This procedure will help eliminate working components from those listed below as the possible cause of unit faults, during error correction and fault diagnosis.**

**1. No display or LEDs illuminated when power switched on.**

- |                               |   |
|-------------------------------|---|
| a) Mains supply failure.      | a) Check mains supply is available and switched on. Check mains plug and plug fuse. Check supply cable for loose connections or breaks.   |
| b) No 24V on power board.     | b) Either of the mains fuses (item 8, Fig.2) failed, see 8.2 to replace fuses. Faulty power switch (item 9, Fig.2), see 8.21 to replace switch. Transformer (item 27, Fig.3) failed, see 8.6 to replace transformer. Wiring fault (mains to fuses, fuses to switch, switch to transformer, transformer to power board). |
| c) No power on display board. | c) Faulty power board (item 26, Fig.3) or faulty wiring or faulty connection to display board. See 8.7 to replace power board.  |
| d) Faulty display board.      | d) Replace display board see 8.27.  |

(continued on page 23)

### FAULT DIAGNOSIS (Continued)

#### 2. A1 illuminated but reservoir full.

- |                                  |  |
|----------------------------------|--|
| a) Reservoir level sensor fault. | a) Reservoir level sensor (item 1, Fig.4) faulty or loose (see section 8.30) or bad connection to power board. |
| b) Reservoir contaminated.       | b) Drain, clean and dry reservoir, then refill.  |

#### 3. A1 Flashing at cycle start - Cycle start requested with low water.

- |                                    |   |
|------------------------------------|---|
| a) Button B6 pressed with A1 'on'. | a) Low reservoir water level, fill as detailed in the 'Instructions for Use'. If indicator A1 is still illuminated when reservoir is full check function of reservoir water level sensor (item 1 Fig.4) for broken wire etc. If indicator A1 was not illuminated when B6 pressed and reservoir empty check indicator A1 using the LED test detailed in 7.5. |
|------------------------------------|---|

#### 4. Cycle selection not possible.

- |                                  |   |
|----------------------------------|---|
| a) Water level in reservoir low. | a) Check A1 Fig.1, if 'on' fill reservoir.  |
| b) Door not closed.              | b) Close door, check A4 Fig.1 illuminated (if not see 'c', 'd' and 'e' below).  |
| c) Door microswitch fault.       | c) Faulty door microswitch (items 18 and 19, Fig.3) or faulty wiring to them. See 8.8 to replace microswitches.                       |
| d) Door close solenoid fault.    | d) Door close solenoid (item 8 Fig.3) faulty, see 8.9 to replace solenoid. 24V power supply to solenoid failed or connections faulty. |
| e) Door adjustment faulty.       | e) Door adjustment stopping primary lock engaging.  |

#### 5. Safety valve leaking.

- |                        |   |
|------------------------|---|
| a) Dirt on valve seat. | a) With low pressure in chamber carefully operate safety valve (item 24 Fig.3) by hand ( <b>Warning: Beware of risk of scalds from escaping steam</b> ). If leakage persists, fit new safety valve, see 8.19. |
|------------------------|---|

#### 6. Safety valve operating at low pressure during cycle.

- |                        |   |
|------------------------|---|
| a) Safety valve fault. | a) Check safety valve and replace if required see 8.19. |
|------------------------|---|

#### 7. Safety valve operating at high pressure during cycle.

- |                                      |   |
|--------------------------------------|---|
| a) Calibration fault.                | a) Recalibrate see 7.4.                 |
| b) Chamber temperature sensor fault. | b) Fit new temperature sensor see 8.11. |
| c) Power board fault.                | c) Fit new power board see 8.7.         |

#### 8. Unusual display when switching on power.

- |                                |  |
|--------------------------------|--|
| a) Power board failed to reset | a) Switch-off power, wait for 10 seconds and switch back on again. |
| b) Power board fault.          | b) Fit new power board (see 8.7) or reprogramme via P.C.           |

#### 9. Error 01 displayed - Power failure during cycle.

- |                          |  |
|--------------------------|--|
| a) Mains supply failure. | a) For display to show error 01 power has already been restored successfully. If error 01 continues to occur check for loose mains connections and wiring or over tightened fuse cover item 8 Fig.2. |
|--------------------------|--|

#### 10. Error 02 displayed - Door opened during cycle.

- |                                   |  |
|-----------------------------------|--|
| a) Door closed microswitch fault. | a) Faulty door microswitch (item 19, Fig.3) or wiring to it. See 8.8 to replace microswitch. |
|-----------------------------------|--|

#### 11. Error 03 displayed - Time for chamber to fill with water too long (time out).

- |                                     |   |
|-------------------------------------|---|
| a) Water fill solenoid valve fault. | a) Water fill solenoid valve (item 11, Fig.3) faulty or connections or supply to it faulty or failed. See 8.4 to replace valve. |
|-------------------------------------|---|

(continued on page 24)



### FAULT DIAGNOSIS (Continued)

- |  |  |
|--|--|
| <ul style="list-style-type: none"> <li>b) Water pipe connection fault.</li> <li>c) Water pump fault (non-vacuum only)</li> <li>d) Low water in reservoir.</li> <li>e) Chamber water level sensor error.</li> </ul> | <ul style="list-style-type: none"> <li>b) Pipes to water fill valve from reservoir disconnected, blocked or kinked (pipes pass via water pump on non-vacuum unit).</li> <li>c) Water pump (item 2, Fig. 4) faulty, or pipe connections to it faulty, or supply to it faulty or failed. See 8.31 to replace pump. Also check on older units that pump is in the new position close to reservoir, if not, or in doubt, contact Eschmann Equipment.</li> <li>d) Reservoir water level sensor error see fault 2 above.</li> <li>e) Water level sensor failure (items 14 and 17, Fig.3) or wiring to them faulty (see 8.23).</li> </ul> |
|--|--|

#### 12. Error 04 displayed - Low water level during cycle (water / steam loss).

- |  |   |
|--|---|
| <ul style="list-style-type: none"> <li>a) Insufficient 'overflow'.</li> <li>b) Chamber integrity fault.</li> <li>c) Large or obscure load</li> <li>d) Chamber too hot at start.</li> <li>e) Bench top not level</li> </ul> | <ul style="list-style-type: none"> <li>a) Chamber fill below that required due to slow fill rate, check faults and solutions in 10 above.</li> <li>b) Chamber has a slow leak (below that to trigger leak test) from any of the following areas. Door seal (check and or replace see 8.13), solenoid valves (check and or replace see 8.4), safety valve (see faults 4 and 5 above), test probe entry ports (check and or replace see 8.32), door face damaged (check and or replace see 8.33), water level sensors in door (check and or replace see 8.23).</li> <li>c) Try a cycle with a smaller load and ensure load can drain, or empty.</li> <li>d) Allow unit to cool and try another cycle.</li> <li>e) Ensure autoclave is level to enable correct water fill levels.</li> </ul> |
|--|---|

#### 13. Error 06 displayed - Chamber temperature too low during sterilization.

- |   |  |
|---|--|
| <ul style="list-style-type: none"> <li>a) Power to heater fault.</li> <li>b) Chamber temperature sensor fault.</li> </ul> | <ul style="list-style-type: none"> <li>a) Low mains voltage check supply. Heater (item 4 Fig.4) gone open-circuit check and or fit new heater see 8.12. Solid state relay or mechanical relay on power board (item 26 Fig.3) failed, fit new power board see 8.7. Thermal fuse open-circuit, replace fuse see 8.26.</li> <li>b) Chamber temperature sensor (item 23 Fig.3) failed or connections to it faulty (see 8.11 to fit new sensor) or in need of calibration see 7.4. Control signal path corruption, check wiring, connections, etc.</li> </ul> |
|---|--|

#### 14. Error 07 displayed - Chamber temperature too high during sterilization.

- |   |  |
|---|--|
| <ul style="list-style-type: none"> <li>a) Chamber temperature sensor fault.</li> <li>b) Power board fault.</li> </ul> | <ul style="list-style-type: none"> <li>a) Chamber temperature sensor (item 23 Fig.3) failed or connections to it faulty (see 8.11 to fit new sensor). Control signal path corruption, check wiring, connections, etc.</li> <li>b) Solid state relay or mechanical relay on power board (item 26 Fig.3) failed, fit new power board see 8.7.</li> </ul> |
|---|--|

#### 15. Error 10 displayed - Time to create chamber pressure drop too long (time out).

- |  |   |
|--|---|
| <ul style="list-style-type: none"> <li>a) Chamber integrity fault.</li> <li>b) Vacuum pump fault.</li> <li>c) Vacuum inlet valve fault.</li> <li>d) Wet, warm chamber</li> </ul> | <ul style="list-style-type: none"> <li>a) See 7b.</li> <li>b) Vacuum pump (item 9 Fig.3) failed or electrical power or pipe connections to it faulty. See section 8.14 to replace pump. If pump running check tubing to vacuum solenoid valve not leaking and pumps diaphragm and valves, see 8.35. Check pipe from chamber to pressure transducer on power board connected and not leaking. Pressure transducer fault change power board see 8.7.</li> <li>c) Vacuum inlet solenoid valve (item 3, Fig.3) faulty or connections or supply to it faulty or failed. See 8.4 to replace valve.</li> <li>d) Chamber conditions at start of cycle too wet and or warm. Restart cycle with dryer colder conditions.</li> </ul> |
|--|---|

**(continued on page 25)**

### FAULT DIAGNOSIS (Continued)

#### 16. Error 13 displayed - Steam quality error, temperature pressure relationship outside set limits.

- |                              |  |
|------------------------------|--|
| a) Air in chamber            | a) Check chamber integrity see 12b. Obscure load (air entrapped) adjust load and try cycle again. Temperature and or pressure sensors faulty or in need of re-calibration, see 8.11 and 8.7 to change power board. |
| b) Steam bleed valve blocked | b) Check and clean / replace as required see section 8.4.  |

#### 17. Error 14 displayed - Time to achieve vacuum (before drying) outside set limits (time out).

- |                              |             |
|------------------------------|-------------|
| a) Chamber integrity fault.  | a) See 12b. |
| b) Vacuum pump fault.        | b) See 15b. |
| c) Vacuum inlet valve fault. | c) See 15c. |

#### 18. Error 15 displayed - Chamber temperature sensors differing by more than preset limit.

- |                                      |             |
|--------------------------------------|-------------|
| a) Chamber temperature sensor fault. | a) See 13b. |
|--------------------------------------|-------------|

#### 19. Error 16 displayed - Real-time clock error

- |                                   |   |
|-----------------------------------|---|
| a) Real-time clock error/stopped. | a) Restart clock by resetting time using special function F8. If this is not successful replace display board see 8.27. |
|-----------------------------------|---|

#### 20. Error 17 displayed - Band heater not working

- |                                    |  |
|------------------------------------|--|
| a) Band heater fault.              | a) Check band heater not open circuit and power is available from SSR etc. check all connections. Check mains voltage . If required replace band heater (see 8.22) or power board (see 8.7).   |
| b) Reset thermostat fault.         | b) Reset thermostat (item 29 Fig.3) and repeat cycle, if thermostat trips again the band heater temperature sensor (item 28 Fig.3) could be at fault (ensure sensor is not dirty or corroded) or in need of calibration (see 7.4). If fault continues replace band heater thermostat (item 29 Fig.3) see 8.34. |
| c) Band heater temp. sensor fault. | c) Ensure sensor is not dirty or corroded, check calibration (see 7.4) fit new sensor if required see 8.20.  |
| d) Heat loss (covers not fitted).  | d) Refit covers and run cycle, covers should always be in place.   |

#### 21. Error 18 displayed - System configuration invalid.

- |                      |  |
|----------------------|--|
| a) EEPROM corrupted. | a) Reconfigure via P.C. or replace Display PCA see 8.27. |
|----------------------|--|

#### 22. Error 19 displayed - Calibration invalid.

- |                      |  |
|----------------------|--|
| a) EEPROM corrupted. | a) Recalibrate see section 7.4, or transfer factory calibration using 'Protected function' P2 then recalibrate as section 7.4. |
|----------------------|--|

#### 23. Error 23 displayed - Wrapped load leak test, pressure rise above set limit.

- |                             |             |
|-----------------------------|-------------|
| a) Chamber integrity fault. | a) See 12b. |
|-----------------------------|-------------|

#### 24. Error 24 displayed - Wrapped load leak test, pressure fall outside set limit.

- |                              |                      |
|------------------------------|----------------------|
| a) Invalid test.             | a) Repeat test.      |
| b) Pressure transducer fault | b) Replace Power PCA |
| c) Power PCA fault           | c) Replace Power PCA |

#### 25. Error 25 displayed - Time to create initial fill vacuum above set limit.

- |                              |             |
|------------------------------|-------------|
| a) Chamber integrity fault.  | a) See 12b. |
| b) Vacuum pump fault.        | b) See 15b. |
| c) Vacuum inlet valve fault. | c) See 15c. |
| d) Wet, warm chamber         | d) See 15d. |

(continued on page 26)

## FAULT DIAGNOSIS (Continued)

### 26. Error 26 displayed - Chamber water level sensors, 'maximum' before 'minimum'.

- |   |  |
|---|--|
| <ul style="list-style-type: none"> <li>a) Sensor wiring fault.</li> </ul> | <ul style="list-style-type: none"> <li>a) Sensors (item 14 and 17, Fig.3) wired wrong way round. Minimum fill sensor (item 14 Fig.3) wire dislodged or broken. Maximum fill sensor (item 17 Fig.3) short after cycle started.</li> </ul> |
|---|--|

### 27. Error 27 displayed - Wrapped load purge time outside set limit.

- |   |   |
|---|---|
| <ul style="list-style-type: none"> <li>a) Power to heater fault.</li> <li>b) Chamber integrity fault.</li> <li>c) Pressure sensor fault.</li> </ul> | <ul style="list-style-type: none"> <li>a) See 13a.</li> <li>b) See 12b.</li> <li>c) Check pipe from chamber to pressure transducer on power board connected and not leaking. Pressure transducer fault change power board see 8.7. Check pressure calibration see 7.4.</li> </ul> |
|---|---|

### 28. Error 28 displayed - Unwrapped purge time 1, outside set limit.

- |   |  |
|---|--|
| <ul style="list-style-type: none"> <li>a) Power to heater fault.</li> <li>b) Chamber temperature sensor fault.</li> </ul> | <ul style="list-style-type: none"> <li>a) See 13a.</li> <li>b) See 13b.</li> </ul> |
|---|--|

### 29. Error 29 displayed - Unwrapped purge time 2, outside set limit.

- |   |  |
|---|--|
| <ul style="list-style-type: none"> <li>a) Power to heater fault.</li> <li>b) Chamber temperature sensor fault.</li> </ul> | <ul style="list-style-type: none"> <li>a) See 13a.</li> <li>b) See 13b.</li> </ul> |
|---|--|

### 30. Error 30 displayed - Time to heat to set point outside set limit.

- |  |   |
|--|---|
| <ul style="list-style-type: none"> <li>a) Power to heater fault.</li> <li>b) Chamber temperature sensor fault.</li> <li>c) Steam bleed valve fault.</li> </ul> | <ul style="list-style-type: none"> <li>a) See 13a.</li> <li>b) See 13b.</li> <li>c) Check steam bleed valve (item 2 Fig.3) wiring and that it opens and closes correctly, replace if required see 8.4.</li> </ul> |
|--|---|

### 31. Error 31 displayed - Chamber maximum temperature outside set limit.

- |   |  |
|---|--|
| <ul style="list-style-type: none"> <li>a) Power board fault.</li> <li>b) Chamber temperature sensor fault.</li> </ul> | <ul style="list-style-type: none"> <li>a) See 14b.</li> <li>b) See 13b.</li> </ul> |
|---|--|

### 32. Error 32 displayed - Chamber maximum pressure outside set limit.

- |  |   |
|--|---|
| <ul style="list-style-type: none"> <li>a) Chamber temperature sensor fault.</li> <li>b) Pressure sensor fault.</li> <li>c) Power board fault.</li> </ul> | <ul style="list-style-type: none"> <li>a) See 13b.</li> <li>b) See 27c.</li> <li>c) See 14b.</li> </ul> |
|--|---|

### 33. Error 33 displayed - Water discharge time outside set limit.

- |  |   |
|--|---|
| <ul style="list-style-type: none"> <li>a) Steam bleed valve fault.</li> <li>b) Water discharge valve fault.</li> <li>c) Chamber water level sensor fault.</li> <li>d) Gauze filter blocked.</li> </ul> | <ul style="list-style-type: none"> <li>a) Stuck open see 30c.</li> <li>b) Water discharge valve (item 2, Fig.3) not opening, check wiring and that it opens and closes correctly, replace if required see 8.4.</li> <li>c) Check sensors (item 14 and 17, Fig.3) not shorted to earth. Also in extreme cases condensation on sensor can give a false reading., repeat cycle and check for repeated error.</li> <li>d) Gauze filter (item 6, Fig.2) blocked by debris, clean around filter then remove it and clean filter or replace with a new one.</li> </ul> |
|--|---|

### 34. Error 34 displayed - Steam discharge time outside set limit.

- |  |   |
|--|---|
| <ul style="list-style-type: none"> <li>a) Steam bleed valve fault.</li> <li>b) Pressure sensor fault.</li> </ul> | <ul style="list-style-type: none"> <li>a) Valve failed shut, see 30c.</li> <li>b) See 27c.</li> </ul> |
|--|---|

(continued on page 27)

### FAULT DIAGNOSIS (Continued)

#### 35. Error 35 displayed - Non vacuum door open (for drying) time outside set limit.

- |                                   |   |
|-----------------------------------|---|
| a) Door open solenoid fault.      | a) Check door open solenoid (item 6, Fig.3) wiring and function.                                    |
| b) Door held closed by vacuum.    | b) Check door seal clean, check all valve functions.  |
| c) Door closed microswitch fault. | c) Check door closed microswitch (item 19, Fig.3) function and wiring, replace if required see 8.8. |

#### 36. Error 36 displayed - Door unlocked during cycle.

- |                                   |   |
|-----------------------------------|---|
| a) Door locked microswitch fault. | a) Check door locked microswitch (item 18, Fig.3) function and wiring, replace if required see 8.8. |
| b) Door solenoid adjustment fault | b) Check door solenoid adjustment/fitting is correct (see section 8.9).                             |
| c) Door lock magnet fault         | c) Check door lock magnet adjustment/fitting is correct (see section 8.10).                         |

#### 37. Error 37 displayed - Band heater above set limit.

- |                                    |             |
|------------------------------------|-------------|
| a) Band heater temp. sensor fault. | a) See 20c. |
| b) Power board fault.              | b) See 14b. |

#### 38. Error 38 displayed - Chamber temperature above set limit at cycle start.

- |                                      |                                       |
|--------------------------------------|---------------------------------------|
| a) Chamber temperature sensor fault. | a) See 13b.                           |
| b) Ambient temperature extreme.      | b) Only run within design parameters. |

#### 39. Error 39 displayed - Chamber temperature below set limit at cycle start.

- |                                      |                                       |
|--------------------------------------|---------------------------------------|
| a) Chamber temperature sensor fault. | a) See 13b.                           |
| b) Ambient temperature extreme.      | b) Only run within design parameters. |

#### 40. Error 40 displayed - Chamber pressure above set limit at cycle start.

- |                                   |                                       |
|-----------------------------------|---------------------------------------|
| a) Chamber pressure sensor fault. | a) See 27c.                           |
| b) Ambient pressure extreme.      | b) Only run within design parameters. |

#### 41. Error 41 displayed - Chamber pressure below set limit at cycle start.

- |                                   |                                       |
|-----------------------------------|---------------------------------------|
| a) Chamber pressure sensor fault. | a) See 27c.                           |
| b) Ambient pressure extreme.      | b) Only run within design parameters. |

#### 42. Error 42 displayed - Band heater temperature above set limit at cycle start.

- |  |                                       |
|--|---------------------------------------|
| a) Band heater temperature sensor fault. | a) See 20c.                           |
| b) Ambient pressure extreme.             | b) Only run within design parameters. |

#### 43. Error 43 displayed - Band heater temperature below set limit at cycle start.

- |                                    |                                       |
|------------------------------------|---------------------------------------|
| a) Band heater temp. sensor fault. | a) See 20c.                           |
| b) Ambient pressure extreme.       | b) Only run within design parameters. |
| c) Calibration error               | c) Recalibrate, see section 7.4.      |

#### 44. Error 44 displayed - Chamber water level high at cycle start.

- |                                      |   |
|--------------------------------------|---|
| a) Maximum water level sensor fault. | a) Water level sensor failure (item 17, Fig.3) or wiring to it. |
|--------------------------------------|---|

#### 45. Error 45 displayed - Chamber water level low at cycle start.

- |                                      |   |
|--------------------------------------|---|
| a) Minimum water level sensor fault. | a) Water level sensor failure (item 14, Fig.3) or wiring to it. |
|--------------------------------------|---|

(continued on page 28)

## FAULT DIAGNOSIS (Continued)

### 46. Error 46 displayed - Door open button pressed 10 times and door failed to open.

- |                               |   |
|-------------------------------|---|
| a) Chamber pressure too high. | a) Wait for pressure to drop and try again. (Door open solenoid programmed not operate with chamber pressure above 115kPa and 115°C). |
| b) Chamber pressure too low.  | b) Vacuum in chamber holding door closed, check all valve functions. Also check door seal and face clean.                             |
| c) Calibration fault.         | c) Recalibrate unit see 7.4.  |
| d) Drain tube tap trapped     | d) Release drain tube tap from between door and panel.  |

### 47. Error 47 displayed - Steam bleed valve failure.

- |                                      |  |
|--------------------------------------|--|
| a) Steam bleed valve fault.          | a) Valve failed to open during purge, see 30c. |
| b) Chamber temperature sensor fault. | b) See 13b.                                    |

### 48. Error 49 displayed - Fan failed to cool chamber during vacuum pulse

- |                                     |   |
|-------------------------------------|---|
| a) Fan not operating.               | a) Check fan connections and function etc.    |
| b) Grill blocked limiting air flow. | b) Check air flow into chamber via grill etc. |

### 49. Error 50 displayed - Band heater sensor reading too high

- |                             |  |
|-----------------------------|--|
| a) Calibration error        | a) Recalibrate autoclave see section 7.4.            |
| b) Band heater sensor fault | b) Replace sensor, see section 8.20 and recalibrate. |

### 50. Error A0 displayed - Test 'Abort Cycle' function selected from PC via 'Support Application'.

This function aborts the cycle running (error 100 recorded for cycle, **ErrAO** on autoclave display). This is useful if the part of the cycle under investigation has been passed allowing the remaining part of the cycle to be aborted to save time. (Note: Loads used during test should be considered non-sterile).



<b>TABLE 5 - PROTECTED FUNCTION P7, QUICK REFERENCE TABLE</b>	
<b>NOTES:</b>	
1. Use button <b>B4</b> to switch the activated component 'on' or 'off'. State is indicated ('on' or 'off') by LED adjacent to button <b>B4</b> (on = on / off = off). 2. If testing 230V items the mains relay should be 'on', or left 'on'.	
<b>DISPLAYED ADC VALUES (scroll with button B1)</b>	
<b>Display D2</b>	<b>ADC (analogue to digital) value displayed in D1</b>
P1 P2 t1 t2 t3	First pressure transducer Second pressure transducer (NB. Not used) First chamber temperature transducer Second chamber temperature transducer Band heater temperature transducer
<b>COMPONENT ACTIVATION (scroll up with button B2, down with button B3)</b>	
<b>Display D3</b>	<b>Component selected 'on' or 'off' by button B4</b>
1 2 3 4 5 6 7 8 9 10 11 12 13 14	Water discharge valve Water fill valve Air admit valve Fan Steam bleed valve Vacuum inlet valve Door open solenoid Door close solenoid Mains relay Water pump Vacuum pump (see note 2 above) Band heater (see note 2 above) Chamber immersion heater (see note 2 above) Audible beeper
<b>SENSOR &amp; MICROSWITCH TEST</b>	
<b>Action to activate component</b>	<b>Progress display LED Illuminated</b>
Short chamber minimum water level sensor to door Short chamber maximum water level sensor to door Operate door closed microswitch Operate door locked microswitch Short reservoir water level sensors together	Second Third Fifth (Fourth extinguished) Seventh (Sixth extinguished) Eighth

## 8 Part removal and replacement

### WARNING

Switch-off and disconnect mains power supply before removing the autoclave cover, or doing maintenance procedures. During certain procedures mains voltage may have to be present with the cover removed and extreme care should be taken to avoid contact with mains voltage.

Check that chamber is at atmospheric pressure before opening the door (see 8.1.3). When the door is opened beware of possible very hot water or steam escaping from the chamber.

### 8.1 General

8.1.1 All the major parts of the autoclave can be easily removed and replaced following removal of the autoclave cover, as detailed in section 8.3. It is important that the autoclave is recalibrated after certain part replacement, where this is required it is called for at the end of the relevant part replacement procedure. **DO NOT FORGET TO REPLACE COVERS BEFORE CALIBRATION.** After all maintenance procedures always run at least one complete cycle to check all functions are working correctly.

8.1.2 The vacuum pump can be refurbished if performance deteriorates as an alternative to complete replacement, see section 8.35.

8.1.3 Before any maintenance procedure especially in the case of an electrical fault, always check the chamber pressure is close to, or at ambient, before attempting to open the door\*. In the case of no electrical power the chamber pressure can be checked on the safety pressure gauge (see 21, Fig.3) behind the door cover. Note that the door cover can be released when the door is locked shut as detailed in section 8.3.1.

\* Note: The door cannot be opened on later models fitted with the pressure door lock until the pressure has fallen below 0.2Bar (Gauge).

8.1.4 After part replacement always ensure that all cable ties removed are replaced correctly after reassembly.

### 8.2 Fuse renewal

Fuses are fitted at the front of the autoclave (item 8, Fig. 2). For fuse ratings refer to 'TECHNICAL DATA'. To extract a fuse switch 'off' the unit and disconnect from the mains power supply, insert a screwdriver or small coin in the slot of the fuse holder and twist it counter-clockwise. After inspecting or renewing a fuse, reverse the above procedure to re-secure fuse holder (DO NOT OVER TIGHTEN). See section 8.28 if the fuse holder assembly is to be replaced.

## 8.3 Cover removal and replacement

### 8.3.1 Front cover removal (see warning above section 8.1).

To remove the front cover place the end of a flat bladed screwdriver into the slot behind the plate marked 'B' in Fig.2 and depress the sprung loaded door interlock pin (see 8.3.4 for orientation of this pin when re-engaging it). Plate 'B' can only be removed using a TX20 Torx pin tamperproof screwdriver. In the event that the door is locked shut, access to plate 'B' in Fig.2 can be gained by opening the printer door (item 15, Fig.2). When the interlock pin is depressed (down) the door cover can be separated from the main autoclave door and door beam. Release the drain pipe and tap (item 14, Fig. 2) from the base of the door and then remove the four front cover retaining screws marked 'A' in Fig.2. Carefully release the door cover and front cover together from the unit (pulling the right hand side out first) until access to the inside of the autoclave has been gained. Release the ribbon cable attached to the display board and the air inlet pipe from the rear of the air filter (vacuum units only). Continue to remove the front covers feeding the drain pipe and tap through the hole marked 'C' in Fig.1. If it is required to operate the autoclave with the front cover removed the ribbon cable can be extended by releasing the ribbon cable clamp.

### 8.3.2 Top cover removal (see warning above section 8.1).

On early models (no side fixing screws) Remove the front cover as detailed in 8.3.1. Slightly raise the front of the top cover and pull it forwards to release the cover from the two retaining spigots on the top of the reservoir (item 30, Fig.3). Lift cover clear of reservoir or continue to slide cover forwards until clear.

On later models (with side fixing screws) On later models the front cover does not need to be removed. Using a TX25 Torx pin tamperproof screwdriver remove the screw on each side. The top cover can then be slide backwards and then up until clear.

### 8.3.3 Top cover replacement.

On early models (no side fixing screws) Slide the top cover into place tilted slightly down at the back until slightly forward of the reservoir. Push the cover down and back to enable the clips inside the cover to engage on the reservoir spigots (item 30, Fig.3). Finally push the cover down at the front to engage the lower retaining clips onto the base of the autoclave. Ensure all four clips are correctly located before replacing the front covers.

On later models (with side fixing screws) Slide the top cover back into place and replace the two side fixing screws (TX25 Torx pin tamperproof screwdriver) to secure it.

### 8.3.4 Front cover replacement.

Ensure the safety valve shield (item 27a, Fig. 9 sheet 2) is positioned correctly as shown in Fig. 9 sheet 2. Position the front cover assembly over the open door in front of the

autoclave and pass the reservoir drain pipe and tap through hole 'C' Fig.2. Reconnect the ribbon cable to the display board and on vacuum units, the air inlet pipe to the rear of the inlet filter. Replace the ribbon cable clamp if removed at 8.3.1 above. Position the cover assembly back into place (left hand side first), replace the cover retaining screws (with the correct shouldered washers in place where required, see Parts List 3) and return the drain pipe and tap into its retaining clips. Check the door spacer (item 34, Fig. 9) is in place before finally depressing the sprung loaded door interlock pin and locating it into the slot at the bottom of the door beam. Note that the top of the door interlock pin (item 2, Fig. 9) has a machined flat that should be aligned to face the door cover (item 1, Fig. 9). Some early units did not have this flat and orientation is not critical. Replace plate 'B' in Fig.2 using the correct tamper proof screws.

### 8.4 Chamber solenoid valves

8.4.1 If the valve assemblies are to be dismantled for cleaning and inspection do not misplace the small internal spring around the sealing plunger or the seal. If only the valve coil has failed (e.g. short-circuiting) it can be replaced.

8.4.2 To clean, replace or repair valves first remove the electrical connection from the valve by removing the crimps from the coil. If replacing the valve, remove the tubing connected to the valve body (**do not forget to clamp the pipe or drain the reservoir when working on the water fill valve**) by cutting through the cable tie (take care not to cut into the pipe).

8.4.3 To replace the coil release the nut and washer on the top of the coil and remove the coil from the valve body. Replace the coil ensuring that the replacement has the same electrical rating (24V, 14W), replace the washers and nut (do not overtighten as this can damage the coil) and reattach the electrical connection. Test the valve function using protected function P7.

8.4.4 To clean the valve remove the coil as detailed above and then release the exposed nut on the top of the valve body. Remove the valve stem and internal parts, clean them and the inside of the valve seating. Reassemble taking care to return parts in the correct sequence and do not overtighten the coil retaining nut. Finally reattach the electrical connection (release the clamp on fill pipe or fill reservoir if carried out at 8.4.2) and test the valve function using protected function P7.

8.4.5 To replace the valve completely release the two retaining screws and shakeproof washers from the base of the valve body and discard. Reattach the new valve (ensure coil has the correct electrical rating 24V, 14W and the small 'O' ring part number 391075 is in place) reconnect the electrical connection and pipe to the valve body, securing it with a cable tie (using Hellerine oil part number 670170 sparingly). Test the valve function using protected function P7.

### 8.5 Reservoir

**8.5.1 Removal.** To remove the reservoir assembly (item 5, Fig.3) for cleaning or replacement drain the reservoir as detailed in the 'Instructions for use'. Cut off the cable ties (taking care not to damage the pipe) from the silicone discharge and vacuum exhaust pipes where they connect to the top of the condensing coil (item 31, Fig.3). Loosen the jubilee clip from the reservoir filling pipe (item 32, Fig.3) and remove both the discharge and exhaust pipe from the reservoir. Remove the reservoir retaining screws and washers from the left and right hand side of the reservoir. Partly withdraw the reservoir with the cap and condensing coil in place. Cut off the cable tie (taking care not to damage the pipe) from the silicone chamber fill pipe where it connects to the fitting at the base of the reservoir and remove the chamber fill pipe. Disconnect the reservoir level sensors electrical connections and then remove the reservoir completely from the autoclave.

**8.5.2 Cleaning.** To clean the reservoir first release the cap and withdraw the condensing coil carefully from the reservoir. Wash the condensing coil and reservoir using a detergent solution ('Teepol' L, is recommended, used as detailed by the manufacturer) using a suitable bottle brush to clean inside the reservoir. Rinse all components thoroughly with tap water to remove any residual detergent. Then rinse all components thoroughly with distilled or deionized water (or water treated by reverse osmosis) to remove any residual tap water. Allow components to dry and reassemble the condensing coil back into the reservoir ensuring that the silicone pipe on the end of the condensing coil lies along the base of the reservoir.

**8.5.3 Replacement.** If replacing the reservoir completely remove the old condensing coil and clean it before reassembly as detailed above. Also remove the two cover retaining spigots (screw and shouldered washer, item 30, Fig.3) the water level sensor and the fill pipe spigot and large washer from the old reservoir. Reassemble the reservoir, condensing coil, fill pipe spigot with large washer (use PTFE tape part number 301600 on spigot thread) the water level sensor and cover retaining spigots. When replacing the top electrical connection for the water level sensor note the following order for the parts - PTFE washer against the reservoir with a steel washer on top, then the electrical connection a steel washer and finally the screw with PTFE tape around thread.

Reconnect both the electrical connections and then the fill pipe (using Hellerine oil part number 670170 sparingly and a cable tie) at the base of the reservoir. Replace the assembly into the autoclave and secure in place. The jubilee clip around the reservoir filling pipe should be tightened to a maximum torque setting of 1.7N m, do **not** exceed this as excess torque could damage the reservoir and filling pipe. Replace the two silicone pipes at the top of the reservoir (vacuum exhaust and discharge) using new cable ties.

## 8.6 Mains transformer

---

Detach the mains transformer (item 27, Fig.3) connections, noting the position of each one. Remove the two retaining screws and shakeproof washers and withdraw transformer. The replacement transformer should be an identical unit, rated at 75VA. To replace the transformer, reverse the removal procedure ensuring the connections are remade in the correct manner.

## 8.7 Power board

---

**Note:** See Appendix 1 before proceeding.

8.7.1 To remove the power board (item 26, Fig.3) release the two thumb nuts at the top of the board taking care not to loose the spacers between the board and supports. Carefully tilt the board away from the reservoir and pull it clear from the base clip with the insulation sheet. When free remove all the connecting cable clips from their sockets on the power board. Cut off (taking care not to damage the pipe) the cable tie around the silicone pipe where it connects to the top of the pressure transducer.

8.7.2 Replacement is simply the reverse of the removal procedure but ensure the correct procedures are used when handling the PCA to protect it from static discharge. Ensure the spacers and the insulation sheet are returned to their original positions and the silicone pipe is reconnected to the pressure transducer (using Hellerine oil part number 670170 sparingly) with a new cable tie.

**Note:** When a new power board is fitted, it will be necessary to recalibrate the autoclave (see Calibration section 7.4).

## 8.8 Door microswitches

---

To remove and replace either of the door microswitches (items 18 and 19, Fig.3) remove the two 'truarc' retaining washers from the microswitch location pillars. Expose the soldered connections to unsolder the join and release the microswitch. Replacement is the reverse of removal but ensure the correct microswitch is used (they are not the same), the insulation sleeve is replaced after soldering the connection and new retaining washers are used. There may be some adjustment required after replacement, ensure they operate and change state correctly.

## 8.9 Door lock/open solenoids

---

To remove a door lock (item 8, Fig.3) or open (item 6, Fig.3) solenoid release the two securing screws and shakeproof washers from the top of the solenoid assembly. To remove the solenoid slide it back (open solenoid) or forwards (lock solenoid) to clear the armature. Remove the two electrical connections and if removing both solenoids note the electrical connections. Replacement is the reverse of the removal procedure but ensure to move the lock closed and push the left-hand solenoid right before tightening the left-hand solenoid screws and move the lock

open and push the right-hand solenoid right before tightening the right-hand solenoid screws. Ensure the door lock mechanism is working freely.

## 8.10 Door lock magnetic catch (vac. only)

---

To replace the magnetic catch (item 7, Fig.3) release its retaining screws and remove. When replacing adjust the close solenoid (Fig. 3, item 8) until the primary lock is fully closed and secure.

## 8.11 Chamber temperature sensors

---

Disconnect the temperature sensors from the wiring loom by releasing their plug from its socket on the loom. Remove the temperature sensors (item 23, Fig.3) up and clear of the chamber. Replace the sensor by the reverse of the removal procedure ensuring a new sealing washer is used and is in place. Finally for vacuum units perform a leak test (special function F4)

**Note:** When a new temperature sensor is fitted, the autoclave must be recalibrated (see Calibration 7.4).

## 8.12 Heating element

---

### CAUTION

**Avoid kinking the capillary tube/s.**

8.12.1 To remove the heating element (item 4, Fig.4) disconnect the electrical spade connections from the element terminals at the back of the chamber. Remove the sterilizing trays, carriers, and chamber furniture from inside chamber and release the thermostat sensor from its clip. (Note: On the non-vacuum unit there are two sensors). Unscrew and remove the large nut from the heater mounting boss at the rear of the chamber. Withdraw the heating element through the chamber door.

### CAUTION

**Ensure that the sensor(s) are correctly positioned, see details in sections 8.24 and 8.25.**

8.12.2 Replacement of the heating element is the reverse of the removal procedure. Ensure that a new sealing washer is used and the element is horizontal when fitted and does not touch the chamber furniture when replaced. Also ensure that the nut is fully tightened, to avoid leaks. Finally for vacuum units perform a leak test (special function F4).

## 8.13 Door seal

---

Open the chamber door and remove the door seal (item 34, Fig.3) from its retaining groove. Ensure the front face and groove in the neck ring and the door sealing face are cleaned with a dry lint free wipe. When fitting a new door seal wipe it with diluted washing up liquid first. Start at the top and work down both sides to the bottom pushing the



seal into the groove at approximately 45°. Ensure that it is correctly seated into its groove and that it is not kinked. (NOTE: DO NOT USE GREASE). Finally for vacuum units perform a leak test (special function F4).

### **8.14 Vacuum pump**

---

**Note:** For pump refurbishment see section 8.35.

8.14.1 To remove the vacuum pump (item 9, Fig.3) disconnect the electrical connection from the wiring loom. Cut off the cable ties (taking care not to damage the pipes) from the silicone pipes where they connect to the pump and release the pipes from the vacuum pump, noting the orientation to ensure correct reconnection. Release the large 'O' ring holding the pump in place and remove the vacuum pump.

8.14.2 Replace the pump by the reverse of the removal procedure ensuring the pipes are connected to the correct pump ports (using Hellerine oil part number 670170 sparingly) with new cable ties.

### **8.15 Cooling fan**

---

8.15.1 To remove the cooling fan (item 10, Fig.3) it is necessary to remove the power board (see section 8.7) to gain access to the fixings. Disconnect the electrical connection from the wiring loom and remove the four screws and shakeproof washers and remove the fan.

8.15.2 Installation is the reverse of the removal procedure. However, when installing the fan ensure that the label is to the top and the cable exits at the bottom to the back left (looking from the front) This ensures that the flow is in the correct direction. Check finger guard is in place.

### **8.16 Bacterial air filter**

---

Remove and replace the bacterial air filter (item 1, Fig.2) as detailed in the 'Instructions for Use'.

### **8.17 Gauze filter**

---

Remove clean and/or replace the gauze filter (item 6, Fig.2) as detailed in the 'Instructions for Use'.

### **8.18 Printer**

---

Remove the printer (item 5, Fig.2) by reversing the fitting instructions provided in the 'Instructions for Use'. To replace the printer follow the notes provided in the 'Instructions for Use'.

### **8.19 Safety valve**

---

To remove the safety valve (item 24, Fig.3) first remove the top screw securing the reservoir spout cup, loosen the bottom screw and rotate the cup out of the way. To remove the safety valve, unscrew it from the chamber neck ring. When replacing the safety valve clean the female thread in the neck ring and apply PTFE tape to the new valves

thread. Rotate the spout cup back into position, replace the top screw but do not tighten screws. Ensure the safety valve shield (item 27a, Fig. 9 sheet 2) is positioned correctly as shown in Fig. 9 sheet 2. Fit the front cover but not the top cover and then tighten the spout cup screws with the spout cup central to the front panel. Finally for vacuum units perform a leak test (special function F4).

### **8.20 Band heater temperature sensor**

---

To remove the band heater temperature sensor (item 28, Fig.3) release the sensor wire from it's connection to the wiring loom and remove the securing nut and shakeproof washer. Refit by reversing the above and ensure that the sensor is in tight contact with the band heater.

**Note:** When a new temperature sensor is fitted, the band heater must be recalibrated (see section 7.4).

### **8.21 Mains switch**

---

To remove and replace the mains switch remove the cable tie securing the cover, lift the cover and remove the four spade connectors from the switch noting the terminals each was connected to. Release the switch from the base tray by pressing the retaining lugs in on each side at the back of the switch. Replace switch by reversing the above ensuring correct orientation and the cover and cable tie are replaced.

### **8.22 Band heater**

---

8.22.1 To remove the band heater (item 4, Fig.3) remove the band heater temperature sensor (see section 8.20) and the power board (see section 8.7). Remove the heater spade connections and release the heater clamp bolts. Carefully slide heater off the chamber vertically by allowing the heater to open up into a 'U' shape.

8.22.2 Refit a new band heater (use threadlock part number 670650 on retaining screws) by reversing the above, referring to sections 8.20 and 8.7 for details on how to refit the temperature sensor and power board.

### **8.23 Chamber water level sensors**

---

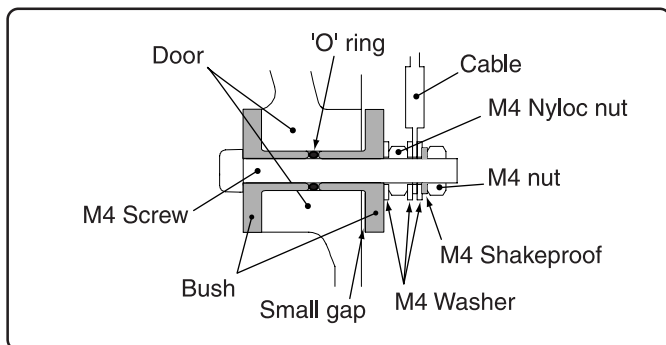
To remove, clean and replace parts of the chamber water level sensors (items 14 and 17, Fig.3) release the door cover to gain access to the fixings and wiring. Remove the outer nut and washers retaining the wire terminal and the nut holding the sensor assembly in the chamber door. Remove the outer bush and the sensor (an M4 x 35mm cap head screw) and bush from inside the chamber door. Clean the internal chamber seating and refit new components as follows:

Remove any burr on the lead-in edge on both sides of the bore and ensure bore is clean. Fit one bush onto the screw, wipe 'O' ring with diluted washing up liquid and fit this onto the screw. Slide this assembly into the bore until the bush is flush with the door. Fit the other bush on the reverse side, a plain washer and then the Nyloc nut.



Tighten this nut until the 'O' ring starts to become compressed then tighten a further half turn (note small gap illustrated, do not tighten nut to eliminate). Fit the remaining washers, nut and ring terminal as shown below. Finally for vacuum units perform a leak test (special function F4).

**Note:** The sensor assembly on early models may be different to that shown below which is now the preferred arrangement. If replacing an assembly the version shown below should be fitted as detailed above, see Parts list 1 (item 34) for component part numbers.



### 8.24 Reset thermostat (overheat)

8.24.1 To remove the Reset thermostat (item 25, Fig.3) and attached bulb, remove two spade connectors from the switch noting the terminals each was connected to. Release switch from the base by removing two retaining screws and shakeproof washers. Free the bulb inside chamber by releasing the clamp around bulb and heater element. Remove capillary tube and bulb through chamber wall by undoing the tubes captive nut from the chambers neck ring. Release capillary tubing from all constraints noting the path taken.

8.24.2 Replace new thermostat and bulb by reversing the above using a new 'O' ring seal (part number 391189) and ensure it is correctly in place around the capillary tube plug before fitting. When repositioning the clamp and bulb they should be approximately 50mm in from the front of the elements left hand segment (viewed from the door end of the chamber). On non-vacuum units lay the bulb into the clamp on top of the cycling (auto reset) thermostat bulb. Fold the clamp legs over to trap the bulb (or bulbs) with a large pair of pliers. Ensure the bulb (or bulbs) are held tight in the clamp and that the tube (or tubes) are routed away from above the element so that they are not damaged by the chamber furniture. Finally for vacuum units perform a leak test (special function F4).

### 8.25 Cycling thermostat (non-vac. units)

To remove and replace the cycling thermostat (item 3, Fig.4) follow the procedure for the reset thermostat (see section 8.24). Both items are removed and replaced using the same procedure.

### 8.26 Thermal fuse (non-vac. units)

**IMPORTANT** If the thermal fuse trips, or needs replacing, the condition of the chamber **MUST** be inspected for any signs of damage or overheating.

To replace the thermal fuse (not illustrated, strapped on the outside of the chamber behind neck ring) simply release the spring clip and disconnect its spade connections. Replace with a new one ensuring the fuse is in close contact with the chamber wall and correctly oriented.

### 8.27 Display board

To replace the display board (fitted behind the display panel) remove all connections and unclip it from the front moulding allowing the ribbon cable from the membrane key pad to pass through the slot in the board. Replacement is the reverse but ensure the correct procedures are used when handling the PCA to protect it from static discharge and the membrane key pad ribbon cable is passed through the slot in the display board and reconnected to it. The PCA will require configuring and calibration using the Autoclave Service Interface Software.

### 8.28 Mains fuse holders

To replace a mains fuse holder (item 8, Fig.2) it will be necessary to remove the water discharge solenoid valve completely, see section 8.4. Fuse holder replacement entails releasing the spade connections, unclipping the old one from the base of the unit and clipping back a new one. Replace the spade connections to the correct terminals then replace the water discharge solenoid valve. Ensure the cover and cable tie are replaced.

### 8.29 Membrane key pad

To replace the membrane key pad (item 3, Fig.2) entails removing the ribbon cable from the key pad to the display board and then prising the key pad away from the front moulding (it is held in place by adhesive). Clean the moulding face before re-attaching a new key pad by removing the release paper on the adhesive and pressing in place. Reattach the ribbon cable to the display board.

### 8.30 Reservoir level sensor

**Do not remove the sensor connections before draining the reservoir.** The reservoir level sensor is fitted in the base of the reservoir and consists of two parts each connected electrically. One connection is to the water fill pipe spigot. The second is above the water fill pipe spigot and it must be connected correctly to avoid leaks and make good electrical connection. This is fully detailed in section 8.5.3. The only parts that would normally require replacement are the sealing washers and PTFE tape around the screw. Do not forget to refill the reservoir.

### 8.31 Water pump

8.31.1 To remove the water pump (item 2, Fig.4) **after draining the reservoir or clamping the supply pipe**, remove it from the spring retaining clip for ease of access. Disconnect the electrical connection by releasing the spring retaining clip on the plug attached to the wiring loom. Cut off the cable ties from the silicone tubes (taking care not to damage the tubes) where they connect to the pump and release the tubes noting the orientation to ensure correct reconnection.

8.31.2 Replace the pump by the reverse of the removal procedure ensuring the pipes are connected to the correct pump ports (using Hellerine oil part number 670170 sparingly) with new cable ties. Refill the reservoir if drained or remove the pipe clamp.

### 8.32 Test probe port & pressure safety gauge

Replacement of a test probe port or pressure safety gauge is self explanatory, but ensure the sealing face is clean and use PTFE tape when refitting. It is not essential that the gauge needle points up vertically at ambient pressure. Finally for vacuum units perform a leak test (special function F4).

### 8.33 Door

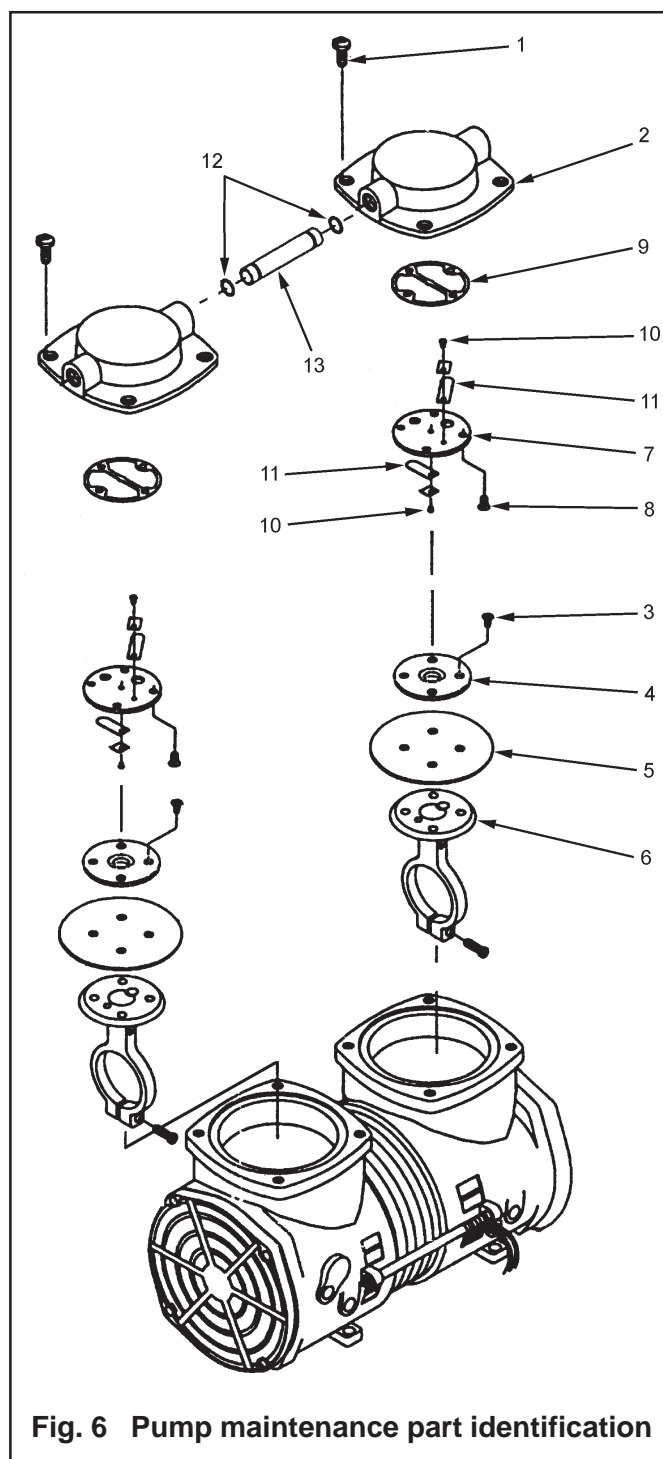
To replace an autoclave door in the unlikely event that it has been damaged first remove the water level sensors (see 8.23) the three test probe ports and pressure safety gauge (see 8.32). The door is removed by releasing the two screws marked 'A' in Fig.3 (but not removing them from the hinge pin). Replacement is the reverse but refer back to sections 8.32 and 8.23. Note that a complete door assembly is available, Part No. 391212.

### 8.34 Band heater resettable thermostat

To replace the band heater resettable thermostat (item 29, Fig.3) remove the electrical spade connections and the nuts and washers that clamp it to the band heater. Replacement is the reverse of removal but ensure the thermostat is in contact with the band heater and the contact area is clean and not corroded.

### 8.35 Vacuum pump maintenance

8.35.1 If the vacuum performance of the pump is poor, but it is operating correctly, it can be refurbished rather than replaced, by the following maintenance procedure. Refurbishment of the vacuum pump entails the replacement of the diaphragm with hold down plate, valve plate seal and 'O' ring in both heads. During dismantling carefully note part orientation for reassembly, failure to assemble in the correct orientation could result in a pump working in reverse, or, with pump heads working against each other. Obtain pump refurbishment kit Part No. 391185 and proceed as follows:



**Fig. 6 Pump maintenance part identification**

8.35.2 Disconnect the two pipes (one on each pump head) by cutting off the cable tie around the silicone pipe (taking care not to damage the pipe). Remove the electrical connection and the pumps retaining 'O' ring and remove the pump from the autoclave.

8.35.3 Remove the four head screws (1, Fig.6) in each head and lift off the two head assemblies (2, Fig.6) together.  
8.35.4 Remove the four diaphragm retainer plate screws (3, Fig.6) in each head, lift off both diaphragm retainer plates (4, Fig.6) remove both diaphragms (5, Fig.6) and discard the old diaphragm retainer plates and diaphragm.

8.35.5 Place new diaphragms on con-rod tops (6, Fig.6) with the new diaphragm retainer plates and replace the screws in a cross pattern using Loctite 242 (Part No.306033) on threads and torque to 2.5Nm, re-torque the first screw to each head.

8.35.6 Remove the valve plate (7, Fig.6) from both head assemblies by removing the four retaining screws (8, Fig.6) and discard the valve plate seals (9, Fig.6) beneath the valve plates.

8.35.7 Remove the two flapper retaining screws (10, Fig.6) in each valve plate and clean the flappers (11, Fig.6) and valve plates. Replace the flappers to their original positions and secure with screws.

8.35.8 Fit new valve plate seals and replace the valve plate assemblies and secure by tightening screws in a cross pattern and torque to 2Nm, re-torque the first screw to each head.

8.35.9 Separate the heads, replace the 'O' ring seals (12, Fig.6) around the connecting tube (13, Fig.6) and reassemble the heads together.

8.35.10 Position one of the diaphragms at the mid stroke position and ensure that the diaphragm is seated correctly. Replace the head and head screws and secure leaving screws loose, position the second head, secure it and finally torque screws in both heads in a cross pattern to 3Nm, re-torque the first screw to each head.

8.35.11 Reassemble the pump in the autoclave and test function and flow before reconnecting the pipes. Finally test the autoclave by running at least one complete cycle. If an abnormal noise is heard, obtain assistance from the Eschmann After Sales Service Department (details inside front cover).

## **8.36 Pressure door lock**

---

8.36.1 If the pressure door lock does not work correctly it should be replaced as a complete unit. There are no user serviceable parts within. However before replacement check that all pipework to the pressure door lock are not blocked or damaged and that the M6 screw on the plunger has not come loose. If either of the later are applicable replace as below.

8.36.2 To replace the pressure door lock release the pipe from the top connection taking care not to damage the pipe. If required also replace the pipe set (part number 111805). Release the four M4 retaining screws and remove the pressure door lock. Remove from the old lock the M6 screw and the spacer for fitting to the new pressure door lock (part number 427035).

8.36.3 Fit the old M6 screw and the spacer to the new pressure door lock using threadlock (part number 306033) on the screw thread. Replace the pressure door lock assembly and connect the tubing to the top connection using a tie wrap (part number 695777). Also use a tie wrap to hold the pipe in place. Test function after replacement to ensure correct operation.

### APPENDIX 1

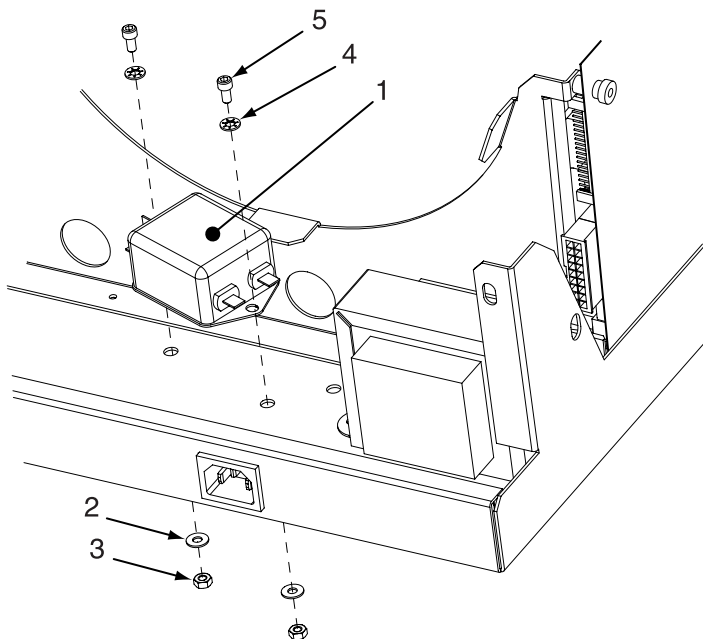
Before replacing a Power PCA check to see if the autoclave is fitted with a Mains Filter (Part number 111703) as shown in the illustration below (item number 1). Then proceed as applicable:

**Mains Filter fitted.** If a Mains Filter is fitted the Power PCA (Part Number 111653) can be replaced as detailed in section 8.7. In this case the autoclave will already be fitted with the new Power Loom (Part Number 111856) and Power PCA (Part Number 111653).

**Mains Filter not fitted.** If a Mains Filter is not fitted then before replacing the Power PCA (which should be replaced with the latest version, Part Number 111653 now common to both vacuum and non-vacuum autoclaves) ensure that both a Mains Filter\* is fitted (see illustration below) and the existing Power Loom\*\* (Part Number 391288) is upgraded. Then replace the Power PCA as detailed in section 8.7

\* The Mains Filter can be supplied as part of a kit (Part number 111700) which includes all the items required to fix it to the autoclave as shown in the illustration below. Ensure the new Power Loom (Part Number 111856) is fitted or the existing Power Loom (Part Number 391288) is upgraded by using loom upgrade kit (Part number 111727) see \*\*.

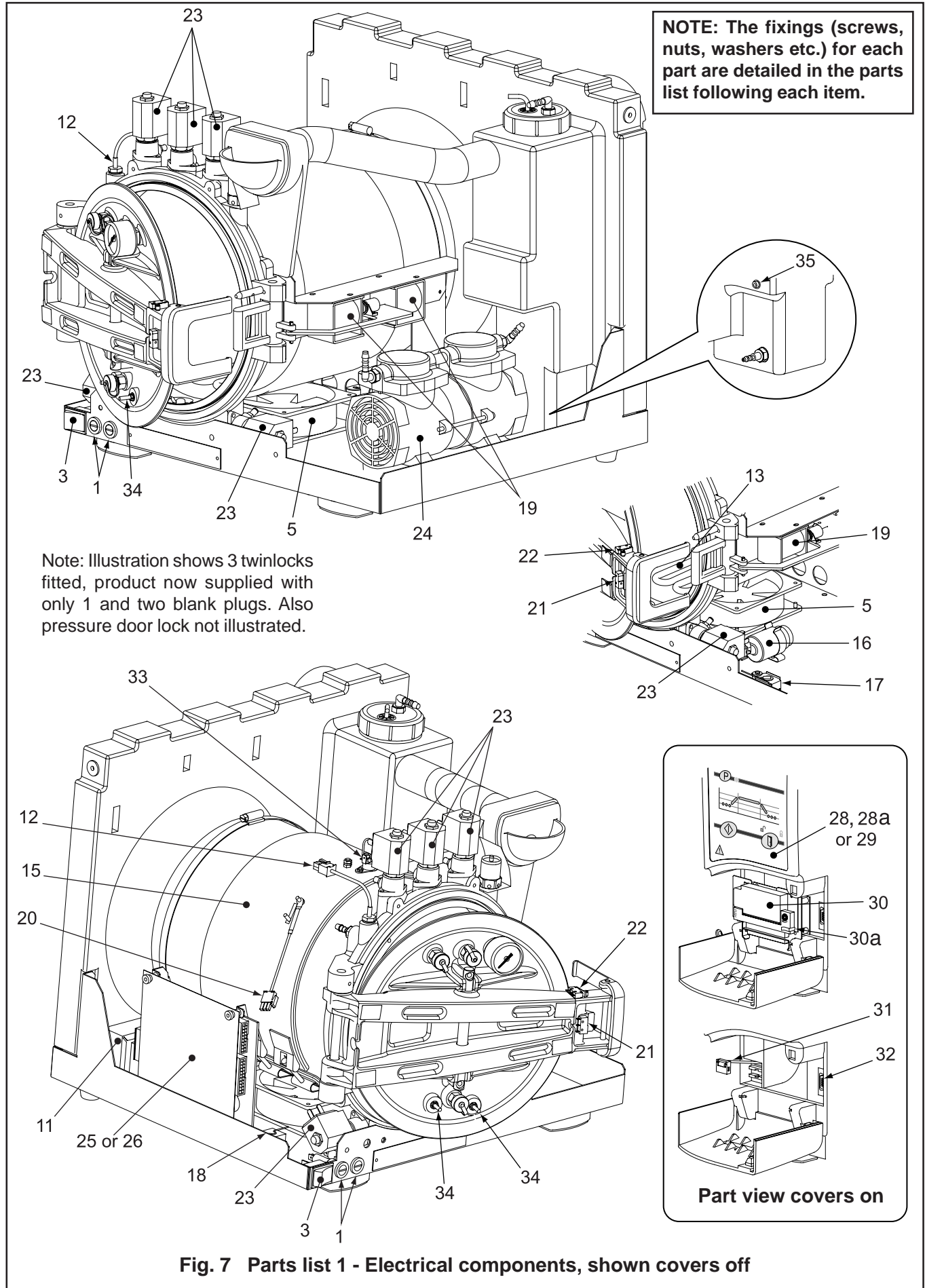
\*\* The existing Power Loom (Part number 391288) can be modified to eliminate replacing the whole loom by using loom upgrade kit (Part number 111727). This kit comes complete with a leaflet providing full fitting instructions. The loom upgrade kit also provides the parts required to upgrade the crimp connections to the Immersion heater, Band heater, Fuse holder and Mains switch.



Item	Part No.	Description	Qty.
1	111703	Mains filter	1
2	307215	M4 Plan washer	2
3	111521	Nut, M4 Nyloc	2
4	307163	Washer, M4 internal shakeproof	2
5	710215	Screw, M4 x 8mm soc. cap hd.	2

**Parts and fixing detail for Mains Filter.**







# LS5/SES2555 & QuickVac

VACUUM & NON- VACUUM AUTOCLAVES

## PARTS LIST 1 - ELECTRICAL COMPONENTS

Item	Part No.	Description	Qty.	Spares
1	391318	Fuse holder	2	1
2 (NI)	301817	Fuse (10 Amp)	2	2
3	391319	Switch, mains	1	-
3a (NI)	391188	. Fuse / Switch cover	1	-
4 (NI)	391145	Socket, IEC	1	-
5	391157	Fan	1	-
5a(NI)	111691	. Finger guard	1	-
	710219	. Screw M4 x 16mm cap head (was 10mm)	4	-
	710731	. Washer M4 shakeproof	4	-
6 (NI)	391299	Ribbon cable (40-way), power to display PCA	1	-
6a (NI)	711348	. Ribbon cable clamp	1	-
7 (NI)	391324	Loom, signal 2 (valves, fan, w.l. sensors, microswitches)	1	-
7a(NI)	391323	Loom, signal 1 (mains transformer, water pump, water reservoir, door solenoids)	1	-
8 (NI)	391288	Loom, power ( <b>see Appendix 1</b> )	1	-
9 (NI)	391388	Loom, water level	1	-
10 (NI)	301842	Grommet	1	-
11	391298	Transformer	1	-
	307249	. Screw M4 x 8mm Pozi head	2	-
	710731	. Washer M4 shakeproof	2	-
12	391036	Sensor, temperature	1	1
	391050	. Washer, Dowty 10mm dia.	1	1
13	391067	Element, heating	1	1
	416149	. Clamp, element temperature sensor	1	-
	425181	. Washer	1	1
	420024	. Nut, element	1	-
14* (NI)	391069	Thermal fuse assembly 10 amp	1	1
15#	391070	Band heater	1	-
16*	391061	Water pump	1	-
	391054	. Spring clip	1	-
	710734	. Washer M3 shakeproof	1	-
	391086	. Screw M3 x 6mm Pozi head	1	-
17#	391084	Cycling Thermostat	1	1
	391086	. Screw M3 x 6mm Pozi head	2	-
	710734	. Washer M3 shakeproof	2	-
	391189	. Spare 'O' ring seal	As Reqd.	1
18	391040	Reset thermostat (overheat)	1	1
	391086	. Screws M3 x 6mm Pozi head	2	-
	710734	. Washers M3 shakeproof	2	-
	391189	. Spare 'O' ring seal	As Reqd.	1
19	391325	Solenoid, door lock/open	2	1
	307249	. Screws M4 x 8mm Pozi head	4	-
	710731	. Washer M4 shakeproof	4	-
20#	391060	Sensor, band heater temperature	1	1
	709861	. Washer M4 plain	4	-
	710731	. Washer M4 shakeproof	1	-
	307046	. Nut 4BA	1	-
21	391066	Microswitch (door locked), lever,	1	1
	709861	. Washer M4 plain	2	-
	391048	. Truarc retaining disc	2	2
22	391065	Microswitch (door closed), roller,	1	1
	709861	. Washer M4 plain	2	-
	391048	. Truarc retaining disc	2	2

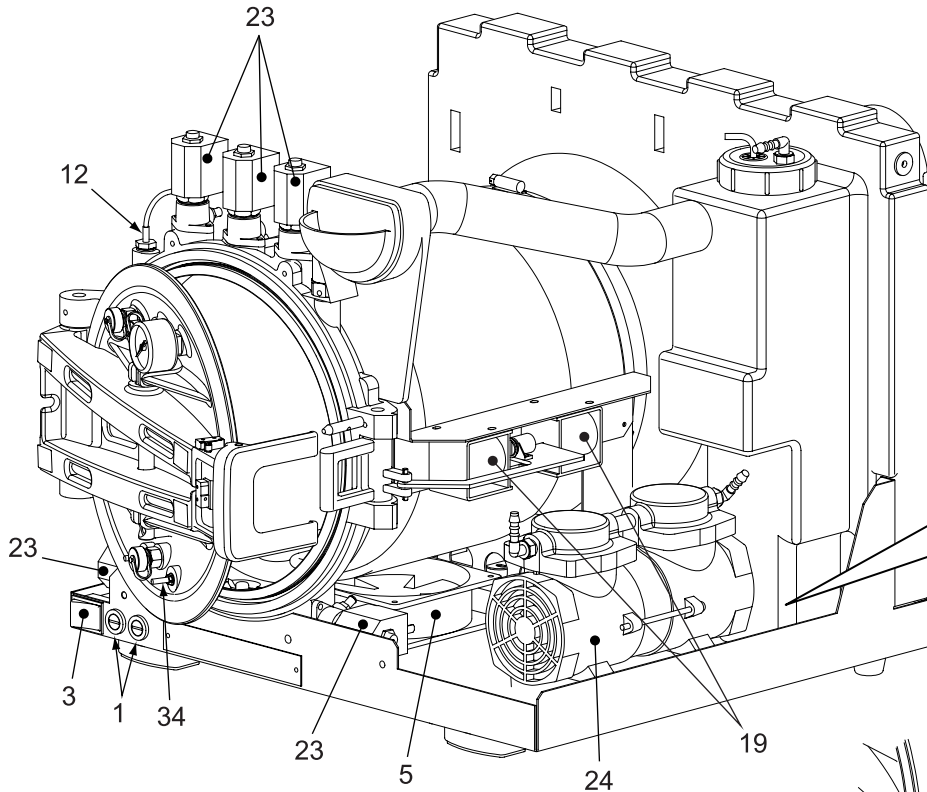
\* = non-vacuum units only

# = vacuum units only

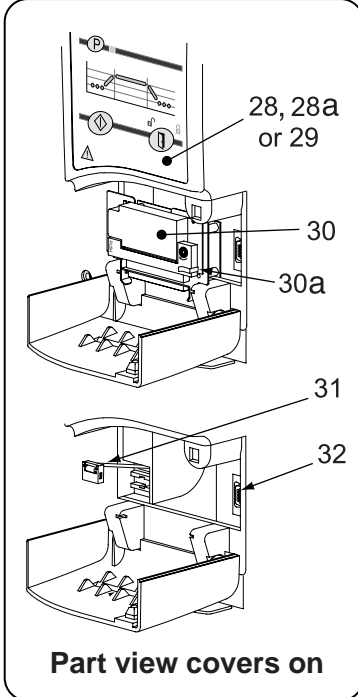
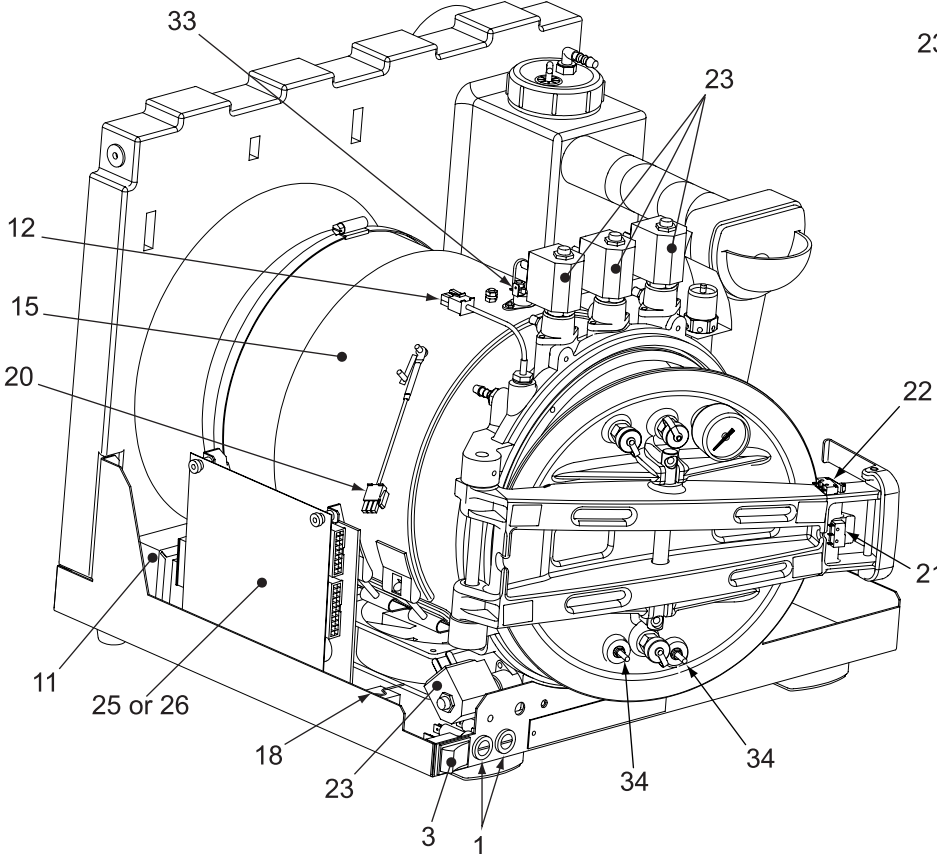
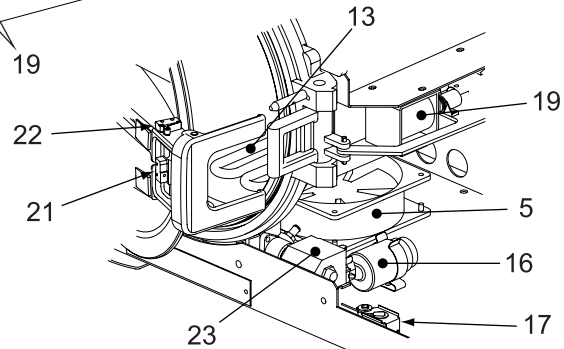
(NI) = Not illustrated

(Continued on page 37)

**NOTE: The fixings (screws, nuts, washers etc.) for each part are detailed in the parts list following each item.**



Note: Illustration shows 3 twinlocks fitted, product now supplied with only 1 and two blank plugs. Also pressure door lock not illustrated.



**Part view covers on**

**Fig. 7 (repeated) Parts list 1 - Electrical components, shown covers off**

# LS5/SES2555 & QuickVac

## VACUUM & NON- VACUUM AUTOCLAVES

### PARTS LIST 1 (Continued) - ELECTRICAL COMPONENTS

Item	Part No.	Description	Qty.	Spares
23	391057	Solenoid valve (only 3 fitted on non-vacuum)	5	1
	710211	. Screw M4 x 10mm cap head	2 per valve	-
	710731	. Washer M4 shakeproof	2 per valve	-
	391075	. Spare 'O' ring for solenoid valve	As reqd.	5
24#	391053	Vacuum pump (for pump kit see 8.35.1)	1	-
	391072	. 'O' ring	1	1
25#	391314	Power board PCA, vacuum autoclave ( <b>see Appendix 1</b> )	1	-
	391097	. PCA insulation sheet	1	-
	696643	. PCA slide	1	-
	301796	. Spacer	2	-
	424171	. Nut, thumb	2	2
26*	391308*	Power board PCA, non-vacuum autoclave ( <b>see Appendix 1</b> )		1 -
	391097	. PCA insulation sheet	1	-
	696643	. PCA slide	1	-
	301796	. Spacer	2	-
	424171	. Nut, thumb	2	-
27 (NI)	391312	Display board PCA	1	-
28#	391016	Membrane key pad for vacuum autoclave (yellow buttons)	1	-
28a##	111772	Membrane key pad for QuickVac & SES2555 (blue buttons)	1	-
29*	391015	Membrane key pad for non-vac. autoclave (yellow buttons)	1	-
30	391010	Printer assembly complete	1	-
30a	391187	Printer ribbon retaining clip (if printer fitted)	1	-
31	391301	Cable assembly, printer (16-way)	1	-
32	391302	Cable assembly, RS232 (9-way)	1	-
	391087	. Screw, M3 x 8mm, Pozi head	2	-
	710734	. Washer, M3 shakeproof	2	-
33	759647	. Band heater reset thermostat	1	-
	709861	. Washer M4 plain	2	-
	710731	. Washer M4 shakeproof	2	-
	307046	. Nut 4BA	2	-
34	111523	DOOR SENSOR ASSEMBLY KIT (two sensors as below)	1 per unit	-
	111520	. Insulation Bush	2	-
	111522	. Screw M4 x 35mm	1	-
	111519	. 'O' ring (VITON)	1	-
	111521	. Nut M4 (NYLOC)	1	-
	709861	. Plain Washers M4	3	-
	710731	. Shakeproof Washers M4	1	-
	710371	. Nut M4 (plain)	1	-
35	-----	RESERVOIR WATER LEVEL SENSOR COMPRISING		
	700237	. Screw M5 x 20mm cap head	1	-
	709862	. Washer M5 plain.	2	-
	391074	. Washer, PTFE	1	1
	-----	EARTH FIXINGS		
	693640	. Metway clamps (primary earth only)	2	-
	709861	. Washer M4 plain	3	-
	710731	. Washer M4 shakeproof	3	-
	710371	. Nut M4	3	-
	-----	MISCELLANEOUS		
	695777	Cable tie	As Reqd.	6
	301600	Tape, PTFE	As Reqd.	1
	714188	IEC Mains lead	1	-

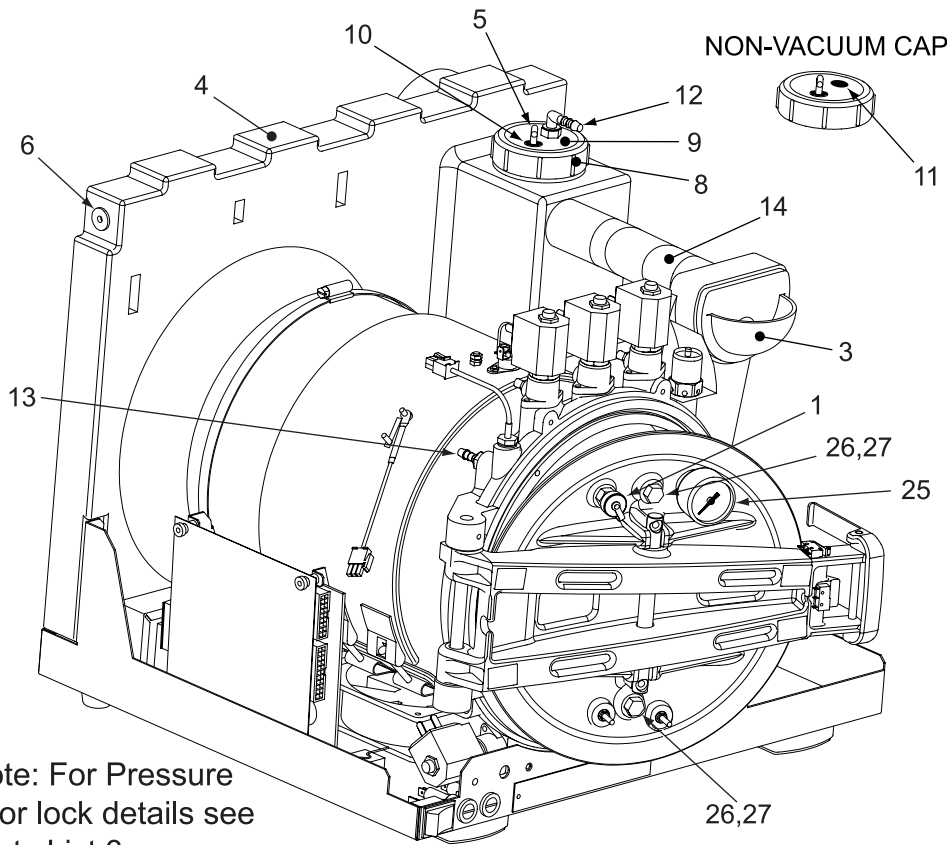
\* = non-vacuum units only

## = QuickVac and later SES2555 vacuum units only

# = vacuum units only

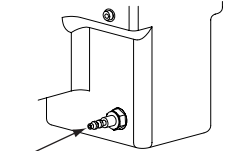
(NI) = Not illustrated

**Note: For information on the Mains Filter see Appendix 1.**

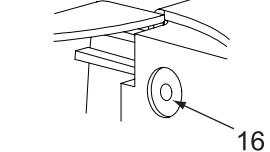


**NOTE:** The fixings (screws, nuts, washers etc.) for each part are detailed in the parts list following each item.

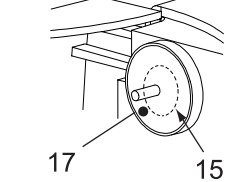
RESERVOIR BASE



NON-VACUUM



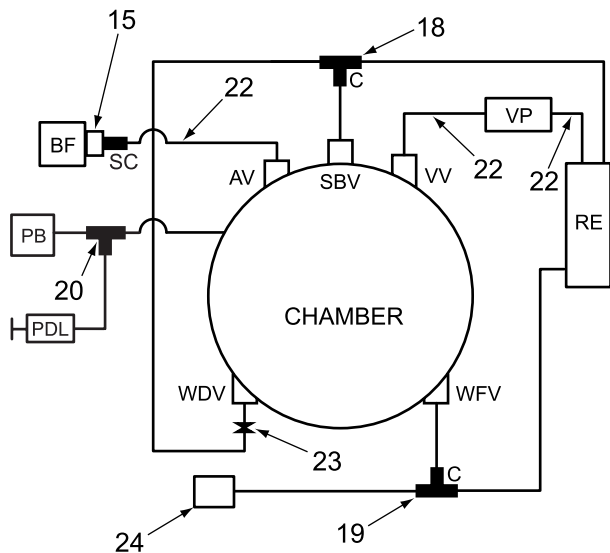
VACUUM



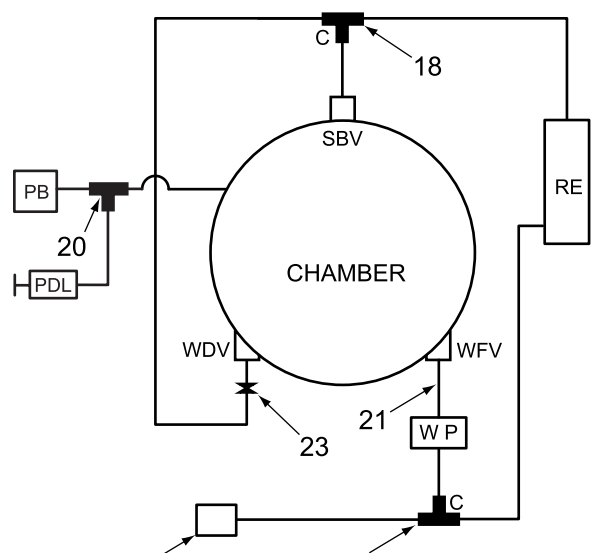
Note: For Pressure door lock details see Parts List 3

**SCHEMATIC PIPE CONNECTIONS & PIPE IDENTIFICATION**

VACUUM AUTOCLAVE



NON-VACUUM AUTOCLAVE



KEY:-

- VP - Vacuum pump
- WFV - Water fill valve
- AV - Air inlet valve
- PB - Power PCB
- W P - Water pump
- C - Y Shaped connector
- SC - Straight connector (supplied with bacterial filter)

- VV - Vacuum valve
- SBV - Steam bleed valve
- BF - Bacterial air filter
- WDV - Water discharge valve
- T - Drain tap
- RE - Reservoir
- PDL - Pressure door lock (if fitted)

**Fig. 8 Parts list 2 - Pipes and plumbing components**

# LS5/SES2555 & QuickVac

VACUUM & NON- VACUUM AUTOCLAVES

## PARTS LIST 2 - PIPES AND PLUMBING COMPONENTS

Item	Part No.	Description	Qty.	Spares
1	301349	Twin lock test plug	1	1
2# (NI)	391140	Screw, 10mm x 12mm Skt cap head	1	-
#	391050	. Washer, Dowty 10mm dia.	2	2
3	391018	Reservoir spout cup	1	-
<b>(NOTE: The new preferred cup fixings shown below may differ from those initially supplied)</b>				
	112012	. Washer, M5 x 16mm (top fixing only)	1	-
	112011	. Washer, spring M5	2	-
	710271	. Screw, M5 x 16mm soc. cap head	2	-
4	391019	Reservoir	1	-
	710119	. Screw, M5 x 10mm Pozi head	2	-
	710733	. Washer, M5 shakeproof	2	-
	111312	. Reinforced hose (inside reservoir)	1	-
5	391035	Condensing coil	1	-
6	391056	Headed bushes (older units only)	2	-
	710119	. Screw, M5 x 10mm pozi head (older units only)	2	-
7	391197	Pipe spigot and filter assembly	1	-
	307252	. Washer (large)	1	1
8	391059	Reservoir cap	1	-
9	391064	Manifold		1 -
10	391079	Cable grommet	1	1
11*	391095	Domed plug	1	-
12#	391080	Elbow		1 -
	301357	. Nut, 1/4" BSP	1	-
13	391055	Pipe spigot	1	-
14	391166	1.25" Bore hose	1	1
	391062	. Jubilee clip	2	-
15#	391033	Air filter mount	1	-
16*	391063	Domed plug	1	-
17#	713580	Bacterial filter and straight connector	1	4
18	391168	Discharge / Air bleed pipe assembly	1	1
19	391169	Fill / Empty pipe assembly for Vacuum autoclave (inc. spiral wrap 391190) OR	1	1
	111011	Fill / Empty pipe assembly for Non-Vacuum autoclave (inc. spiral wrap 391190)	1	1
20	391170	Silicone tube, 400mm x 3mm Ø x 2mm wall OR If Pressure door lock fitted:	1	1
	111805	Pipe set, pressure door lock	1	1
21*	391171	Silicone tube, 280mm x 5mm Ø x 2mm wall	1	1
22#	391172	Silicone tube, 450mm x 5mm Ø x 2mm wall	3	-
23	391156	Restrictor	1	-
24	380010	Drain tap	1	-
25	391175	Gauge, pressure/vacuum safety	1	-
26	380020	Plug, 1/4" BSP 884/2	2	1
27	391132	Washer, Dowty 1/4" BSP	2	1
	-----	MISCELLANEOUS		
	695777	Cable tie	As reqd.	10
	301600	PTFE tape	As reqd.	1
	670170	Hellerine oil (pipe fitting lubricant)	As reqd.	1
	391077	Silicone tube (per metre) (3mmØ x 2mm wall)	As reqd.	-
	391078	Silicone tube (per metre) (5mmØ x 2mm wall)	As reqd.	-

\* = non-vacuum units only

# = vacuum units only

(NI) = Not illustrated





# LS5/SES2555 & QuickVac

VACUUM & NON- VACUUM AUTOCLAVES

## PARTS LIST 3 - GENERAL ASSEMBLY COMPONENTS (Fig. 9 Sheet 1)

Item	Part No.	Description	Qty.	Spares
1	391002	Door cover	1	-
	391009	. Pin, spring, printer location	1	-
	391006	. Hinge pin, top	1	-
2	391012	Pin, door linkage	1	-
	391013	. Spring, door linkage pin	1	-
3	391004	Hinge plate, door bottom	1	-
	710091	. Screw, M5 x 10mm Pan head	2	-
4	391003	Printer door	1	-
5	391146	Fastener, ¼ turn	1	-
6	391143	Front panel moulding	1	-
	391005	. Bush, door hinge	2	-
	710119	. Screw, M5 x 10mm Pozi head (was Pan head)	4	-
	111193	. Shouldered washer (top fixing screws only if fitted)	2	-
7	391102	Overlay label	1	-
8	391022	Door, chamber	1	-
9	391028	Seal, door	1	2
10	391037	Filter, gauze chamber	1	2
11	391043	Top cover (older models)	1	-
or	111648	Top cover (with side fixings)	1	-
	111767	. M5 x 10mm Torx pin screw	2	-
12	391046	Foot, small rear	2	-
	391090	. Screw, M5 x 16mm Pozi head	2	-
13	391038	Foot, large front	2	-
	391090	. Screw, M5 x 16mm Pozi head	2	-
30	391187	Printer ribbon retaining clip (if printer fitted)	1	-
31	111409	Blanking plate	1	-
32	110953	. Screw, M4 x 12mm Torx pin c.sk.	2	-
33	111692	Printer roll holder	1	-
34	391198	Door spacer	1	-
	-----	MISCELLANEOUS		
	391141	Label, LS5 Door cover	1	-
	391142	Label, SES2555 Door cover (green)	1	-
	391138	Label, reset press here symbol	1	-
	111782	Label, QuickVac Door cover	1	-
	111783	Label, SES2555 Door cover (blue)	1	-

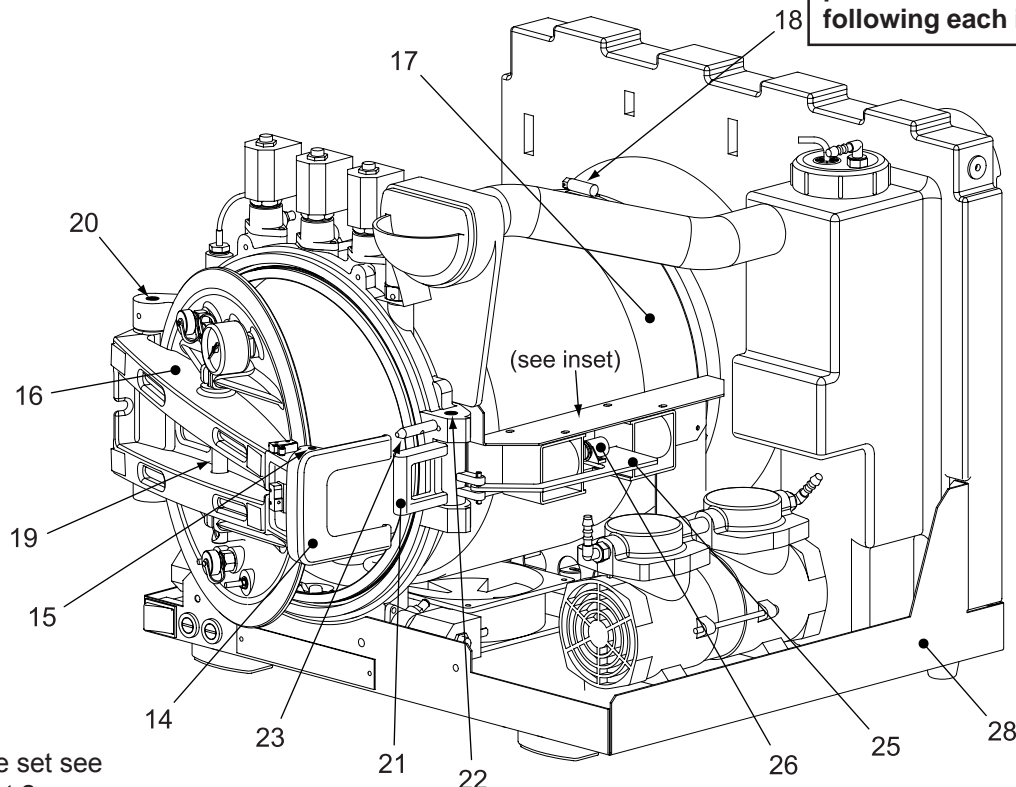
\* = non-vacuum units only

# = vacuum units only

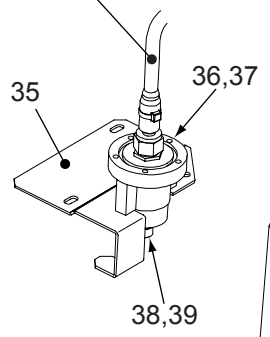
(NI) = Not illustrated

(continued on page 46)

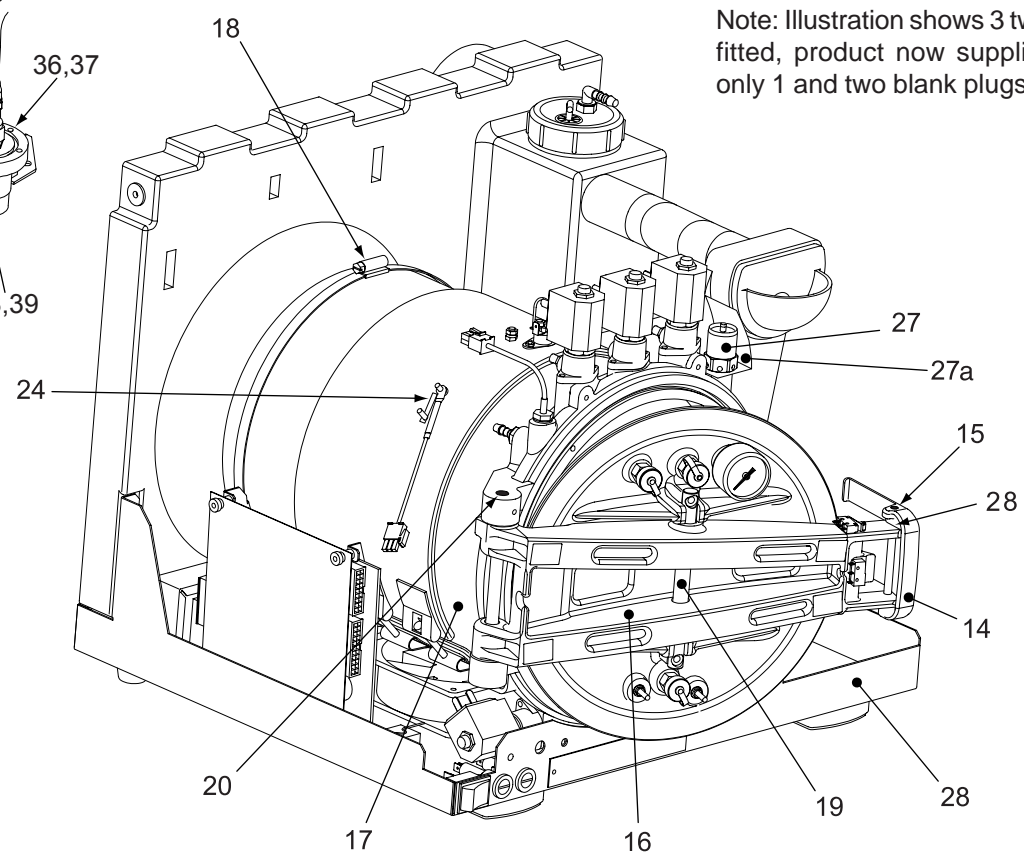
**NOTE: The fixings (screws, nuts, washers etc.) for each part are detailed in the parts list following each item.**



For pipe set see Parts list 2



Note: Illustration shows 3 twinlocks fitted, product now supplied with only 1 and two blank plugs.



**Fig. 9 sheet 2 Parts list 3 - General assembly components**

# LS5/SES2555 & QuickVac

VACUUM & NON- VACUUM AUTOCLAVES

## PARTS LIST 3 - GENERAL ASSEMBLY COMPONENTS (Fig. 9 Sheet 2)

Item	Part No.	Description	Qty.	Spares
14	391024	Secondary catch	1	-
	391049	. Spring	1	1
15	391032	Pivot pin (secondary catch)	1	-
16	391083	Door beam	1	-
	391047	. Pin, Sellok 2mm Ø x 16mm (microswitch supt)	4	4
17	391025	Chamber neck ring assy	1	-
	710441	. Bung, M10 grub screw	2	-
	710280	. Bung, M6 grub screw	2	-
	710019	. Screw, M5 x 10 slotted head (was Pozi hd)	2	-
	710733	. Washer, M5 shakeproof	2	-
18	391051	Jubilee clip	1	-
19	391029	Pin, door pivot	1	-
	307239	. Screw, M5 x 16 cap head	2	-
	710733	. Washer, M5 shakeproof	2	-
20	391030	Pin, door beam pivot	1	-
	699158	. Pin, Sellok 4mm dia x 25mm	1	1
21	391082	Catch, primary lock	1	-
22	391031	Pin, primary catch pivot	1	-
	699158	. Pin, Sellok 4mm dia x 25mm	1	1
23	391105	Pin, Microswitch actuation	1	-
24	424444	Calibration clip	1	-
	709861	. Washer, M4 plain	1	-
	710731	. Washer, M4 shakeproof	1	-
	307046	. Nut, 4BA	1	-
25	391042	Link, primary lock solenoid	1	-
	699188	. Pin, 4mm x 16mm Sellok (for solenoid spindle)	2	-
	699158	. Pin, Sellok 4mm x 25mm	1	-
	391074	. Washer, PTFE	3	-
26	391139	Catch, magnetic (vacuum autoclave only)	1	-
	710371	. Nut M4	1	-
	391086	. Screw, M3 x 6 Pozi head	2	-
	710734	. Washer, M3 shakeproof	2	-
27	391071	Pressure relief valve	1	1
27a	391191	Safety valve shield	1	-
28	391041	Chassis and base plate assembly	1	-
29	391199	Plastic spacing washer (1.19mm)	1	-
	or 391201	Plastic spacing washer (0.84mm)	1	-
35	111804	Bracket pressure door lock	1	-
36	427035	Pressure door lock assembly	1	-
37	110535	Screw M4 x 12mm PV Pan head Pozi	2	-
38	710154	Screw M6 x 25mm Soc cap head (use retainer 306033)	1	-
39	111762	Spacer	1	-
	-----	MISCELLANEOUS		
	670070 (or 306055)	Grease, door mechanism	As reqd.	1
	306234	Pipe adhesive, chamber plugs	As reqd.	-
	301600	PTFE Tape	As reqd.	1
	670650	Screw retainer	As reqd.	1
	695777	Cable tie	As reqd.	6
	391173	Universal rack	-	-
	391174	Vertical cassette holder	-	-
	REF 87-041-45	Dental handpiece furniture set	-	-

\* = non-vacuum units only

# = vacuum units only

(NI) = Not illustrated

## 9 TECHNICAL DATA

---

### 9.1 Electrical

---

Supply 230V 50/60 Hz a.c.  
~ For use with alternating current  
Loading at 230V 2.0kW 10A (max.)  
Fuses T10A (Part.No.301817) (x2)  
T3.15A (Part.No.696207) (x1)

### 9.2 Sterilizing data

---

**Standard:**

Sterilizing time at 134/137°C is 3min. 5sec., at 121/124°C is 15min. and at 134/137°C (extended) is 18min. (but all can be extended)

**All:**

Drying time (if selected) is from 17 minutes (but can be extended).

Operating pressure at 121°C is 1.03 bar, at 124°C is 1.23 bar, at 134°C is 2.03 bar and at 137°C is 2.32 bar.

### 9.3 Maximum Load

---

Tray	-	-	1.5kg maximum per tray
Cassette	-	-	2.0kg maximum per cassette
Chamber	-	-	8.0kg maximum total chamber load

### 9.4 Water reservoir capacity

---

8.0 litre

### 9.5 Weight (approx.)

---

Non-Vacuum	Net	= 42.5kg
	Shipping	= 55.5kg.

For Vacuum add 6.5kg.

### 9.6 Safety standards

---

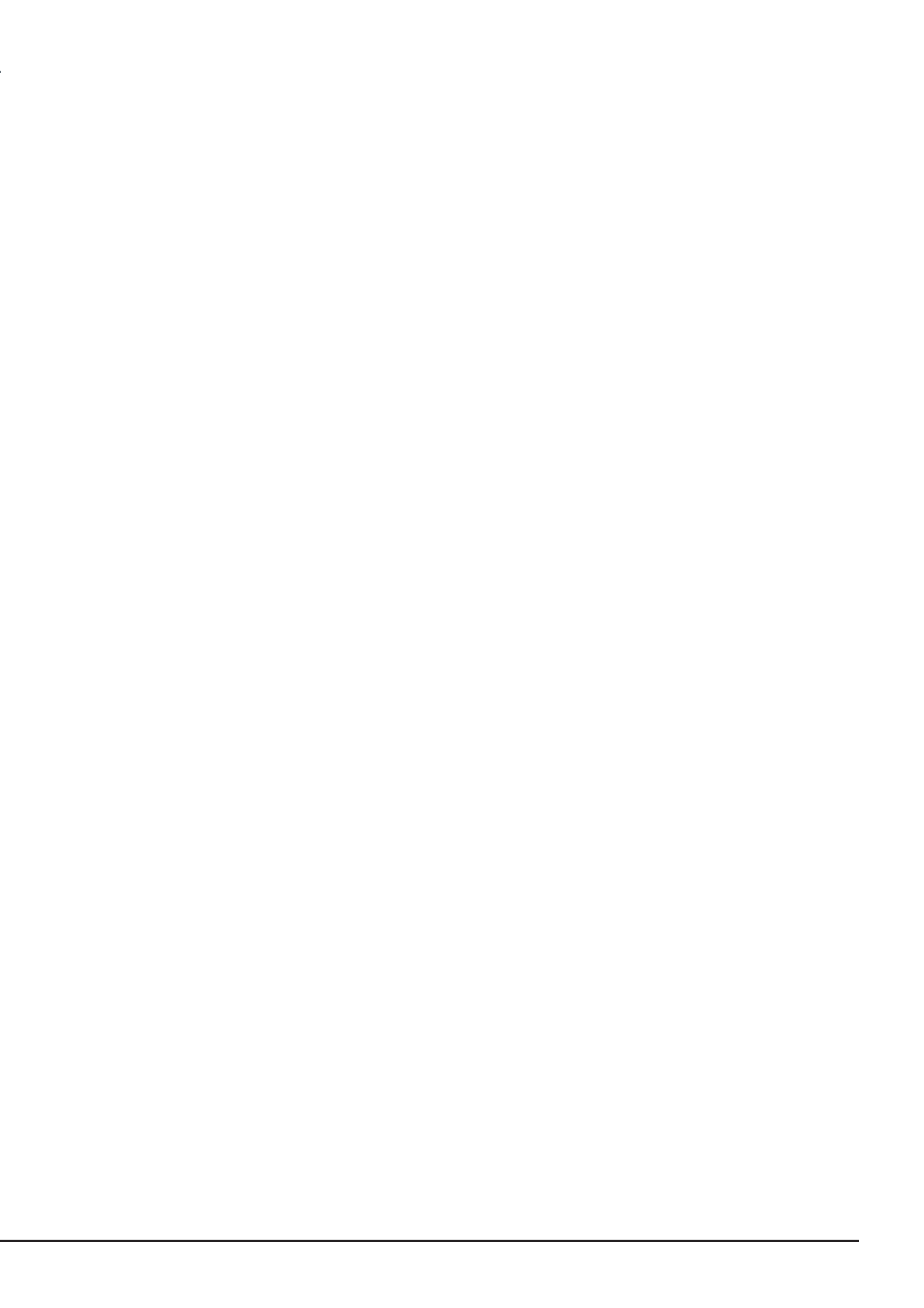
EN 61010-1 (1993) inc. Amendment 2 (1995)  
EN 61010-2-041 (1996)

### 9.7 Design pressure

---

2.85bar (gauge)





**DISCOVER NEW INNOVATION. NEW TECHNOLOGY. DISCOVER  ESCHMAN**

---

Eschmann Equipment, Peter Road, Lancing, West Sussex, BN15 8TJ, England.  
Tel: +44 (0) 1903 753322. Fax: +44 (0) 1903 766793. [www.eschmann.co.uk](http://www.eschmann.co.uk)

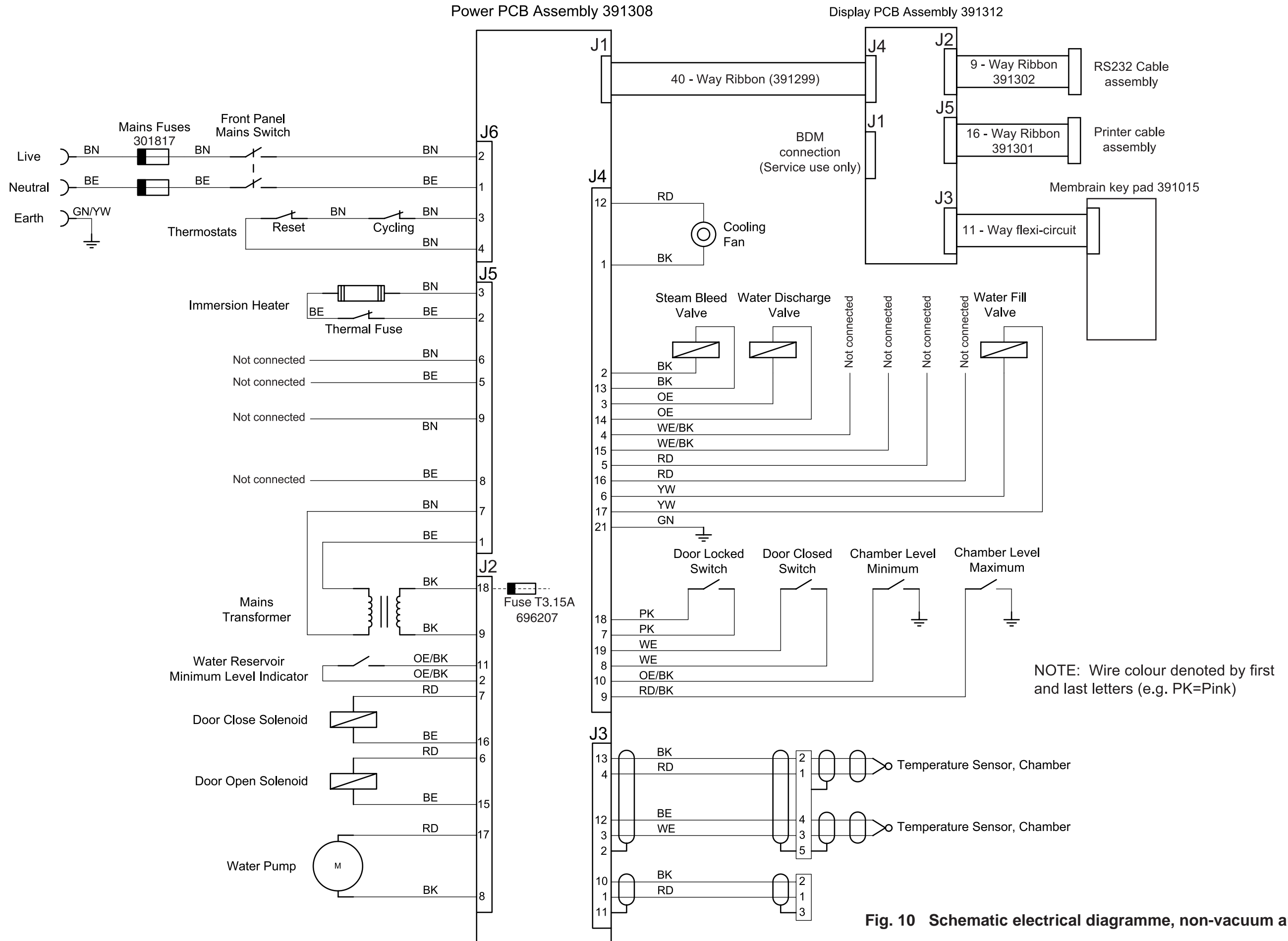


Fig. 10 Schematic electrical diagramme, non-vacuum autoclave

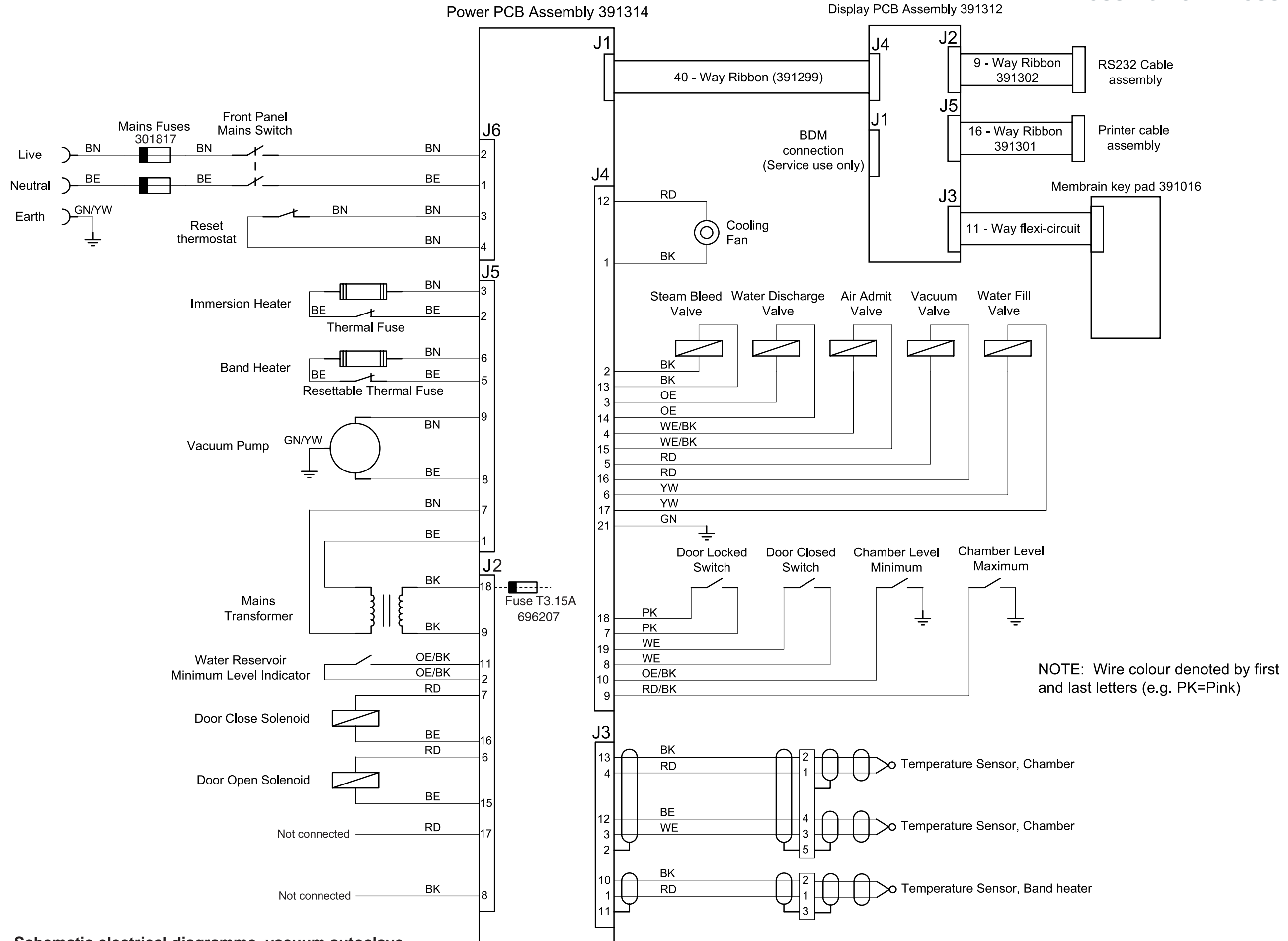


Fig. 11 Schematic electrical diagramme, vacuum autoclave

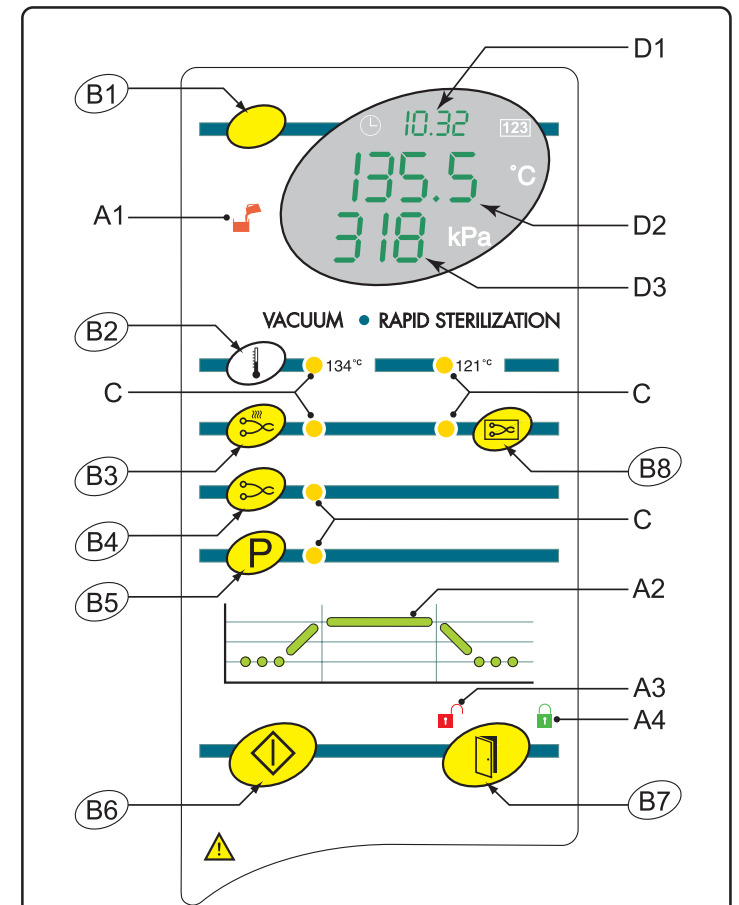


Fig. 1a Control panel for SES2555 and LS5

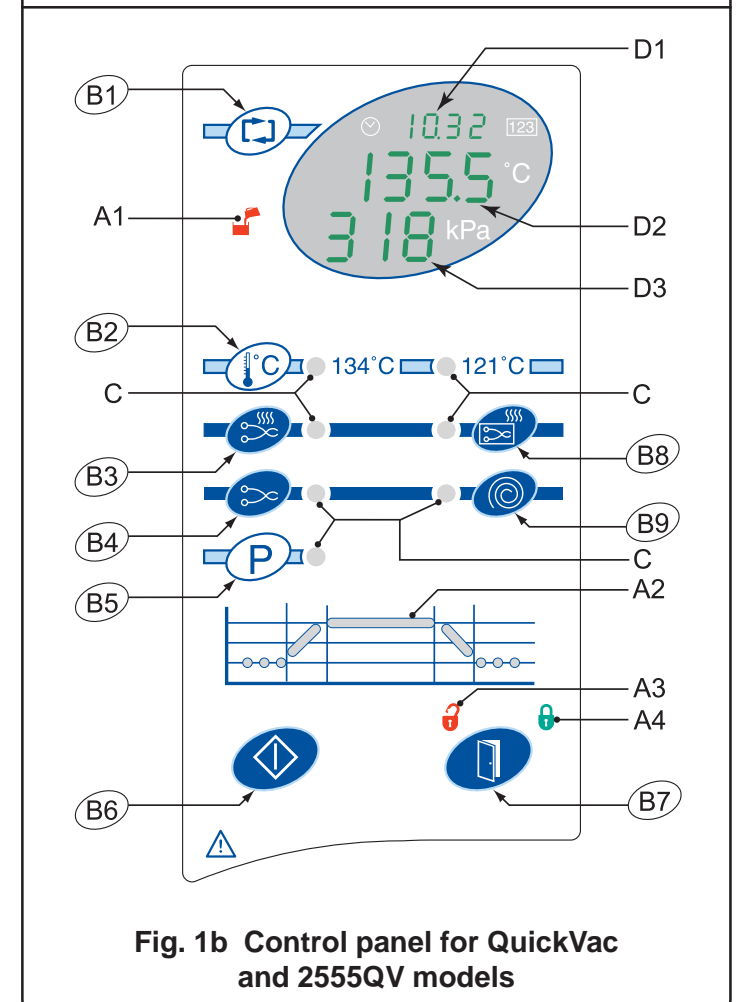


Fig. 1b Control panel for QuickVac and 2555QV models