



P200

- linear steady state characteristics
- integrated hydraulic accumulator
- through shaft
- safe to run dry (liquid)
- self-priming up to 4 meters depth
- liquid fertiliser-proof (AHL/UAN)

Capacity at 5 bar:	200 l/min
Nominal speed:	540 U/min
Operating time pressure:	max. 15 bar
Short-term pressure:	max. 20 bar
Speed range:	450-600 U/min
Spline shaft:	DIN 9611/ISO 500
Standard working diaphragms:	4 x NBR
Accumulator diaphragms:	1 x NBR
Inlet- ϕ suction side:	AS50
Outlet- ϕ pressure side:	AS30
Lubrication:	Oil bath
Weight:	22 kg/26 kg
Material:	Cast aluminium, partially anodised, NBR seals, POM, stainless steel: 1.4305

Options:

- Desmopan® diaphragms
- Through shaft
- Hydraulic drive

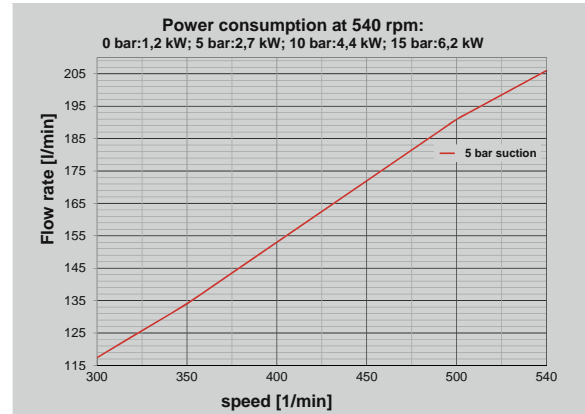

Pump options

Article-No.	Type
82406	Piston diaphragm pump P200 with bracket and pto protection

More variations on request

Recommended fittings inlet (AS2)

17330	Plug-in hose tail AS50/ ϕ 46/90° cpl
17157	Plug-in hose tail AS50/ ϕ 46 cpl

Recommended fittings outlet (AS1)

08337	Plug-in hose tail AS30/ ϕ 25/90° cpl
33793	Plug-in hose tail AS30/ ϕ 33/90° cpl
81119	Plug-in hose tail AS30/ ϕ 25 cpl
01399	Plug-in hose tail AS30/ ϕ 33 cpl

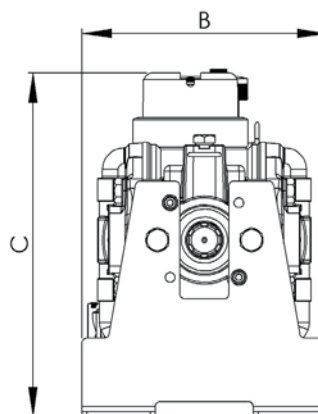
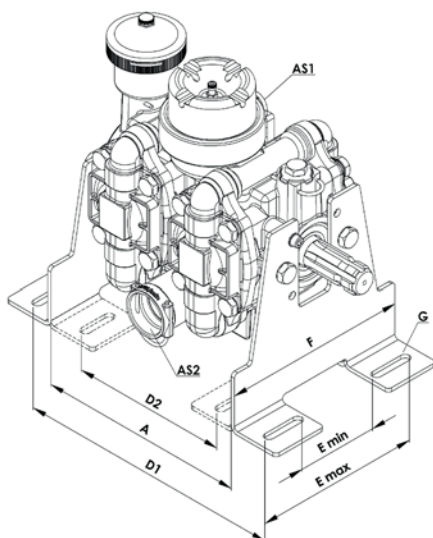

A	B	C
310	274	357
D1	D2	E _{Min}
390	240	110
E _{Max}	F	G
225	250	M12
Specified in mm		