

Mobile crane

LTM 1060-3.1

Max. lifting capacity: 60 t

Max. lifting height: 63 m

Max. working radius: 48 m



LIEBHERR

Mobile crane LTM 1060-3.1

Strong and flexible



A long telescopic boom, high capacities, an extraordinary mobility as well as a comprehensive comfort and safety configuration distinguish the mobile crane LTM 1060-3.1 from Liebherr. The 60-tonne crane offers state of the art technology for more convenience in practical operation.

- 48 m telescopic boom and 16 m folding jib
- Hoist heights up to 63 m and radii up to 48 m when used with folding jib
- High lifting capacities with full ballast and part ballast
- Flexible axle load versions using variable ballast concept
- 36 tonne overall weight, incl. 5.5 tonne counterweight at 12 tonne axle load
- Sensitive operation using the modern Liebherr crane control





Drive train

- Six-cylinder Liebherr turbo-diesel engine, 270 kW/367 hp, max. torque 1700 Nm
- Automated ZF-AS Tronic gearbox, 12 forward and 2 reverse speeds
- 2-stage transfer case, 0.59 km/h crawling speed
- Axles two and three driven, axle one as option

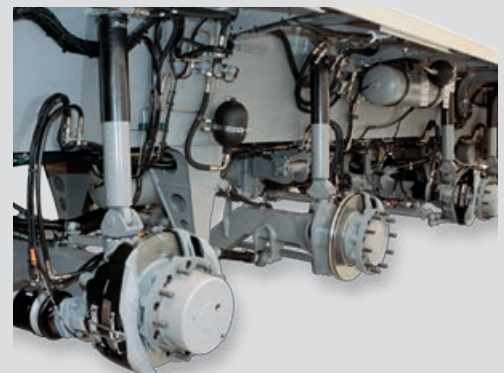
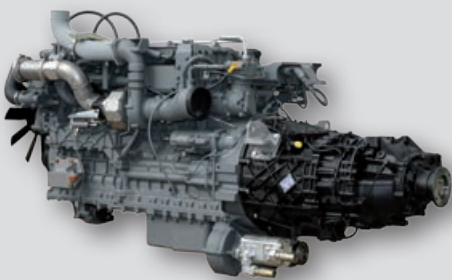

State-of-the-art chassis and drive technology



High mobility and cost effectiveness

A powerful six-cylinder Liebherr turbo-diesel engine with 270 kW/367 hp ensures swift driving performance. The 12-speed gearbox with automated ZF-AS Tronic control system provides a high level of cost effectiveness and excellent comfort.

- Reduced fuel consumption due to the large number of gears and the high efficiency of the dry clutch
- Excellent manoeuvrability and minimum crawling speed due to two-stage transfer case
- ABV automatic blocking prevention
- Telma eddy current brake optional, wear free and comfortable

Compact, agile and weight-optimised

Thanks to its extremely compact design, the LTM 1060-3.1 can operate on the smallest of construction sites. At an axle load of 12 t, it can drive with up to 5.5 t of counterweight, making it flexible and economical to use.

- Chassis length only 9.44 m
- Smallest turning radius only 7.59 m
- Vehicle width only 2.55 m, even with 445/95 R 25 (16.00 R 25) tyres
- Tail swing radius only 3.54 m

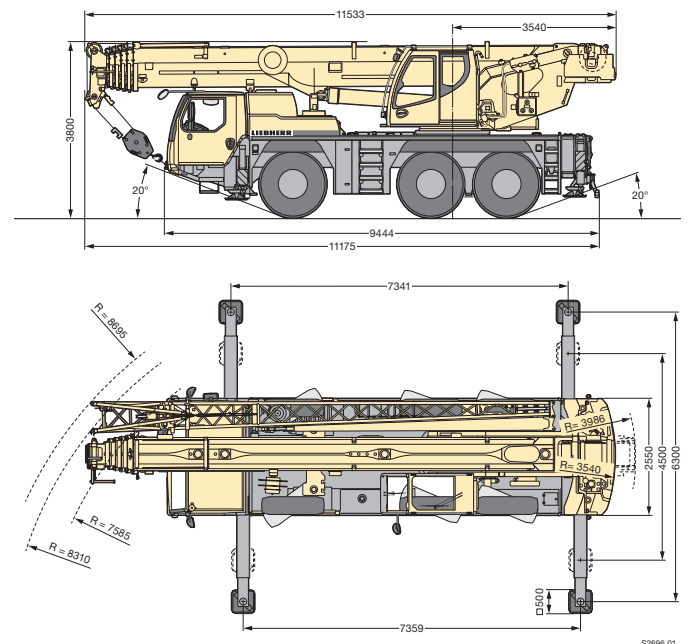

S2696.01

Hydro-pneumatic axle suspension "Niveaumatik"

- Maintenance-free suspension cylinders
- Large dimensions to cope with high axle loads
- Suspension travel: +100/-100 mm
- High lateral stability when cornering
- Choice of driving states using fixed programmes



Pneumatic disc brakes

- High braking power, improved control
- Improved directional stability
- No reduction of braking force at high braking temperatures (fading)
- Longer service life
- Shorter labour times for changing the braking pads
- Brake pads with wear indicators



5 steering programmes

- Selection of programme by simple push button
- Clear layout of control elements and displays
- Programmes changeable during driving
- Crab steering comfortably controlled by steering wheel

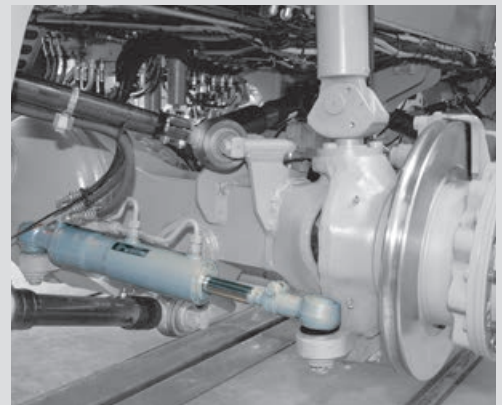

Variable steering concept



Centring cylinder on the rear axles

- Automatic straightening of rear axles in case of failure

Active rear axle steering

The rear axles are actively electro-hydraulically controlled in accordance with the speed and steering angle of the front axle. Five different steering programmes (P) can be selected by touch button.

- Remarkably reduced tyre wear
- Improved manoeuvrability
- Stable driving condition even at high speeds
- All three axles can be steered

High safety standards – entire know-how from Liebherr

- Centring cylinder for automatic straightening of rear axles in case of failure
- Two independent hydraulic circuits with wheel and engine driven hydraulic pump
- Two independent control computers

P1 Road steering

The axle 1 is mechanically steered by the steering wheel. The axle 3 is actively steered depending on the speed and on the steering angle of the 1st axle. Above 30 km/h it will be adjusted to straight driving and fixed.

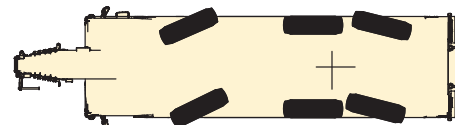

P2 All-wheel steering

The axles 2 and 3 are turned by the steering wheel depending on the steering angle of the 1st axle to provide for the smallest turning radius.



P3 Crab steering

The axles 2 and 3 are turned by the steering wheel to the same direction as the steering position of axle 1.

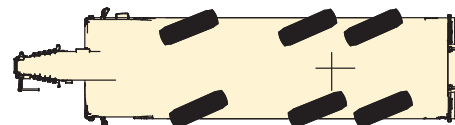

P4 Reduced swing out

The axles 2 and 3 are turned depending on the wheel turn of the 1st axle to minimize the back swing of the rear of the chassis.

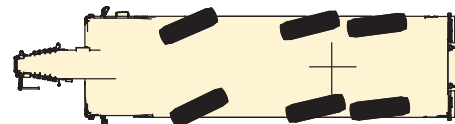

P5 Independent rear axle steering

The axle 1 is steered by the steering wheel, the axles 2 and 3 are steered by push buttons independently from the steering angle of the axle 1.

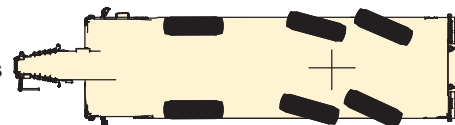



The driver's cab

- Corrosion resistant
- Electric window lifters
- Safety glass on all sides
- Tinted glass
- Heated and electrically adjustable outside mirrors
- Air-sprung driver's seat with lumbar support

Comfort and functionality

Modern driver's cab and crane cab

Both the modern driver's cab and the crane cab offer a comfortable and functional working environment. The control elements and displays are ergonomically arranged. Thus a safe and fatigue free working is assured. For the driver cabin, the crane cabin, the ignition lock and tank cap a single key system is provided.

Speedy and safe set-up

Setting of the outriggers, counterweight assembly and attachment of additional equipment have all been designed with speed, safety and comfort in mind. Specific ascents, handholds and rails are provided to ensure the safety of the operating staff.



Supporting crane on outriggers – quick, comfortable and safe

- BTT Bluetooth Terminal, mobile control and display unit
- Electronic inclination display
- Fully automatic levelling by push button
- Engine start/stop and speed control
- Support area lighting with four integrated lights
- Support cylinder stroke: 650 mm front, 700 mm rear
- One-stage outrigger beams, fully hydraulic, low maintenance extension system

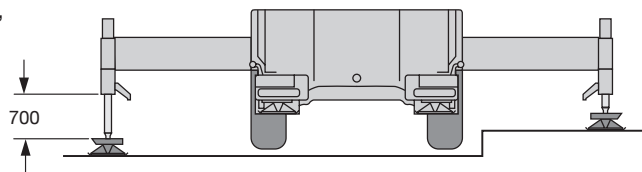

The crane cab

- Large field of vision
- Safety glazing
- Tinted window panes, hinged front and roof screens
- Crane driver's seat with lumbar support
- Corrosion resistant
- Working floodlight
- Engine-independent heating
- 20° tiltable to the rear

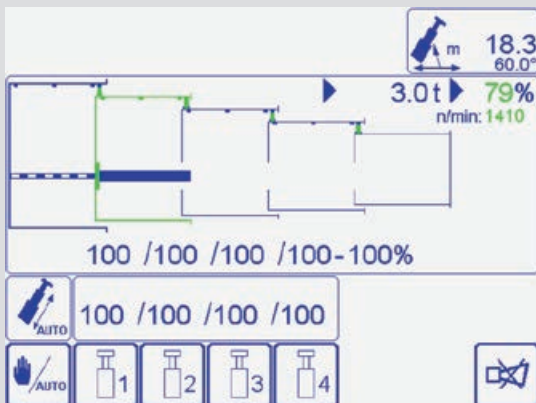
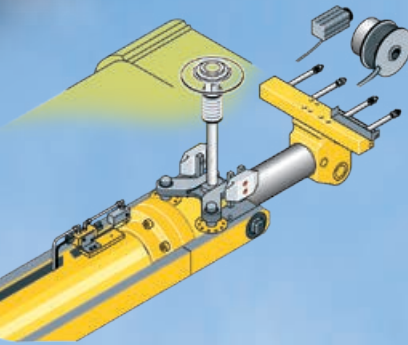
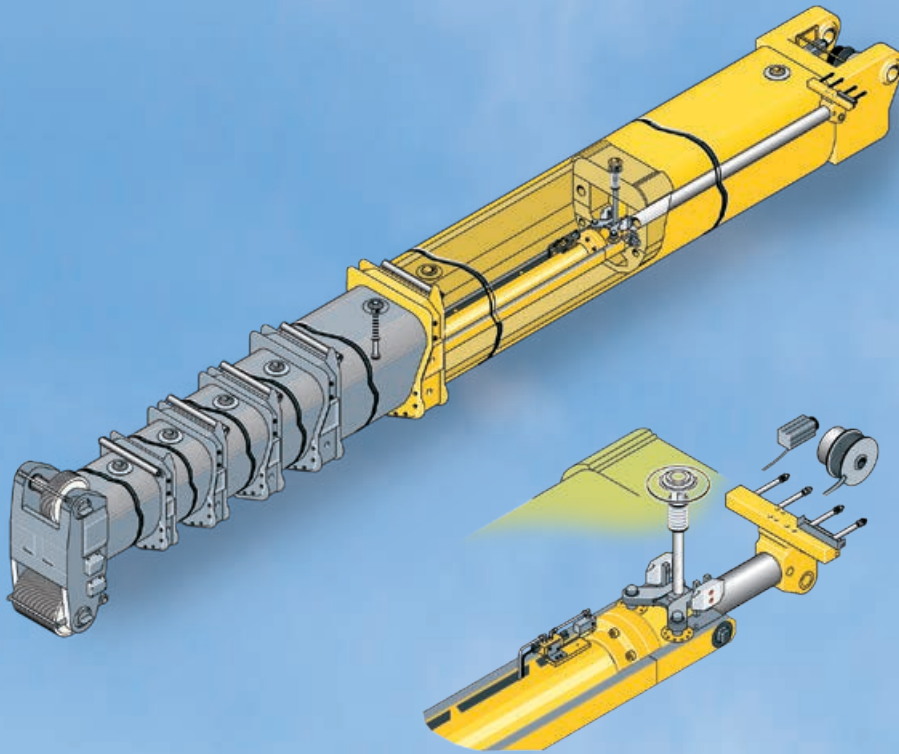
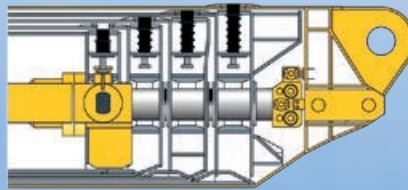
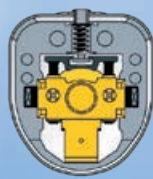

The fully automatic telescoping system „TELEMATIK“

- Improvement of capacities at long booms and large radii due to light-weight telescoping system
- 1-stage hydraulic cylinder with hydraulically operated drive pin
- Maintenance free telescoping
- Telescoping fully automatic
- Simple operation, supervision of telescoping at the LICCON monitor

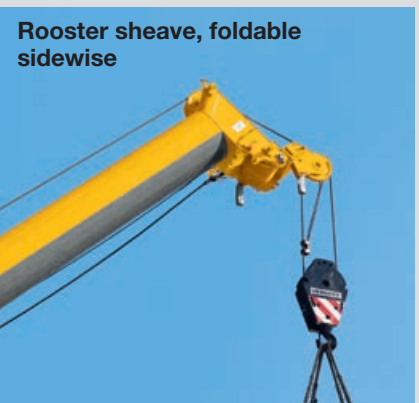

High lifting capacities and flexible boom system



Powerful, long telescopic boom and functional lattice extensions

The telescopic boom consists of the base section and 5 telescopic sections, which can be comfortably and automatically extended and pinned to the requested length by the thousand fold proven single cylinder telescoping system TELEMATIK.

- 48 m long telescopic boom
- 9.5 m – 16 m long double swing-away jib, attachable at 0°, 20° and 40°
- Rooster sheave, foldable sidewise
- 2.5 m long assembly jib

High capacities with full counterweight as well as with partial counterweight offer a wide application of operations

- High lateral stability due to the oval boom profile
- Optimized capacities due to the numerous extension variations
- Capacity 6.3 t at 48 m long telescopic boom

High capacities at the unpinned telescopic boom

- High telescopic capacities due to interpolation
- Separate charts for holding of loads at unpinned telescopic lengths
- Display at LICCON monitor



← Holding capacity

← Unpinned telescopic length

← Telescopic capacity

2.5 m long assembly jib



Hydraulic assistance for assembly of the swing-away jib with BTT



Variable counterweight

Counterweight assembly - a matter of minutes

- Multiple counterweight variations from 3.7 t to 12.8 t
- Rapid ballasting with keyhole technology from within the crane cab
- Compact counterweight dimensions: with 12.8 t counterweight, the width is only 2.55 m
- Tail swing: only 3.54 m
- 36 t total weight incl. 5.5 t counterweight at 12-t axle load

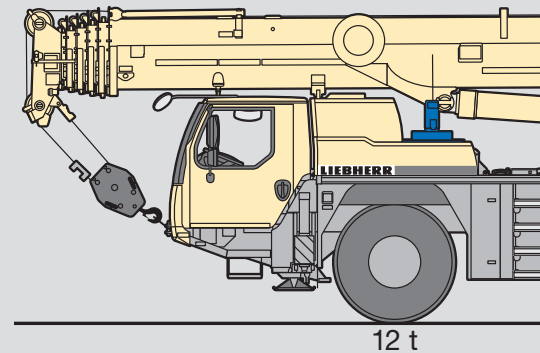

The hoist gear

- Hoist gear with integrated planetary gear and spring loaded multi-disc brake
- Line pull 45 kN at outer layer
- Maximum line speed 130 m/min
- 2. hoist gear optional



High-power crane drive

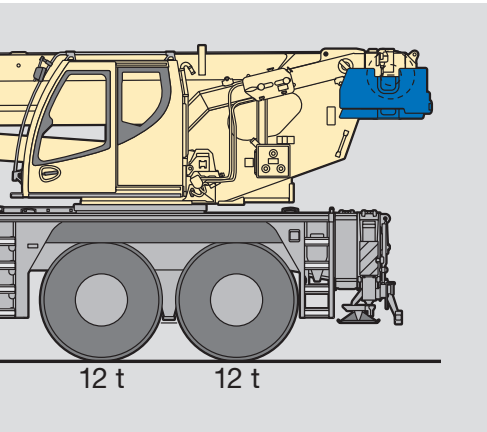

With tried-and-tested components

The drive components for crane operation are designed for high performance and ensure sensitive and precise load handling. They are specially designed to suit the crane's usage and have been subjected to hard endurance tests.

- Crane drive from chassis engine
- Optimized fuel consumption by electronic engine management
- Diesel-hydraulic crane drive, open hydraulic circuits with electronic "Load Sensing" control, 4 working movements simultaneously possible
- Electric/electronic SPS crane control through the LICCON computer system
- Comfort armrest control with 2 self-centering, 4-fold multifunctional joysticks, stepless control of all crane movements, with vibration joysticks for slewing gear and winch operation, electronic pilot control
- Slewing system changeable from open to hydraulically locked as standard, thus the movement can be adjusted to the different operational conditions, e. g. sensitive control for assembly work or fast cycle work

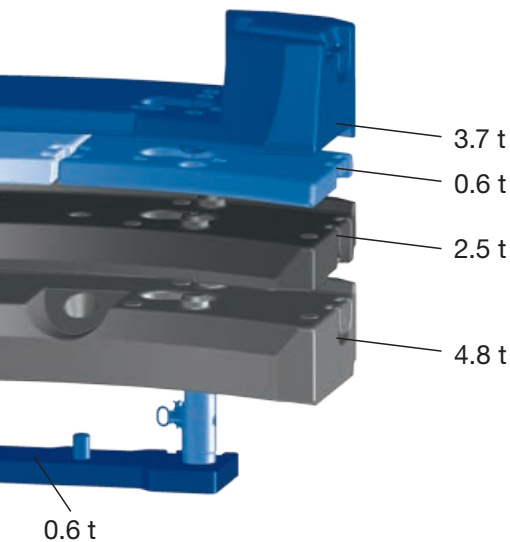

Basic counterweight 5.5 t
Additional counterweight 7.3 t
Total **12.8 t**

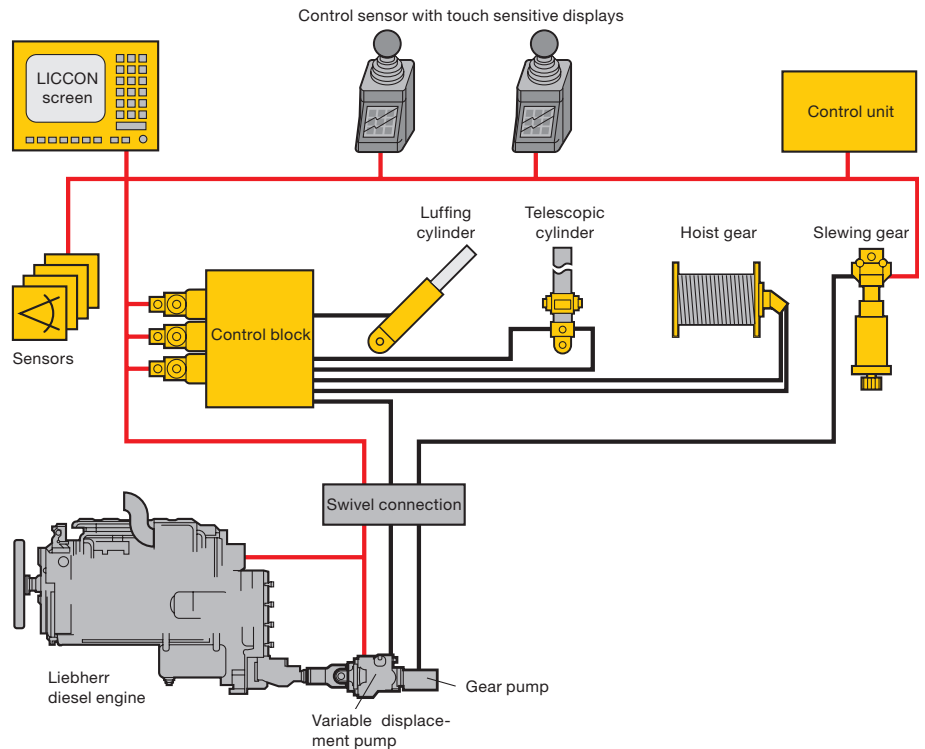

The slewing gear

- Planetary gear, spring loaded multi-disc brake
- Slewing speed from 0 – 1.6 m/min step less adjustable
- Slewing gear changeable from open to hydraulically locked



Centralised lubrication

- Centralised lubrication system as standard for slewing ring, boom bearings, luffing ram and winch bearings
- Uniform application of lubricant
- Lubricant level visible in transparent container at all times



The LICCON test system

- Rapid localisation of problems on screen without any measuring instruments
- Display of error codes and descriptions
- Convenient interactive functions for monitoring all inputs and outputs
- Displays of functions and allocation of sensors and actuators

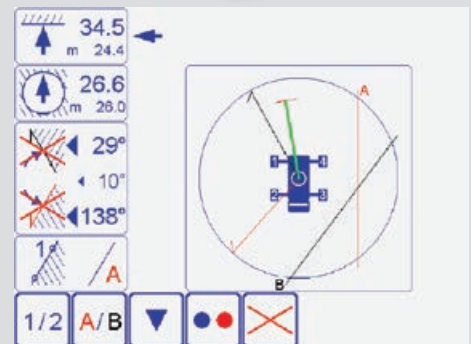

Intelligent crane control

For functional and safe crane operation: the LICCON computer system

The soft and hardware of the mobile crane control is developed by Liebherr in-house. The centre is the LICCON computer system (Liebherr Computed Control).

- Integrated LML load moment limiter
- Key components are in-house manufactured by Liebherr
- Guaranteed spare parts availability
- Worldwide proven under the most different climate conditions
- Operator friendly
- High reliability due to data bus technology

The second control generation LICCON2 is the result of a continuous development by the Liebherr specialists and enables the adaption to the constantly increasing demands of the markets due to its modern and future oriented control.

€COmode

for more efficient mobile crane jobs

- Lower fuel consumption
- Lower noise emissions

In "€COmode" the crane driver sets the required working speed using the control lever. The LICCON2 control then calculates the perfect engine speed for it. This value is set on the crane engine using the engine control unit. Fuel savings are up to 10%.

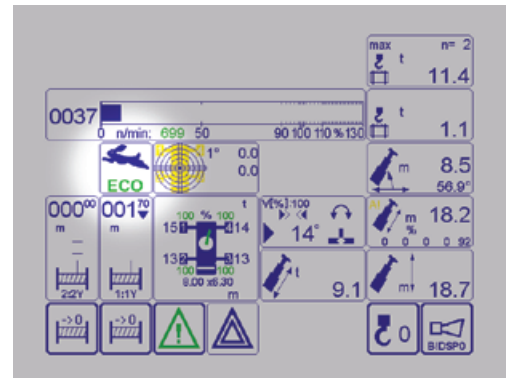

The LICCON working range limiting system

- Relief for the crane operator's job by automatically monitoring workspace restrictions such as bridges, roofs, etc.
- Simple programming
- Four different limitation functions:
 - Pulley-head height limitation
 - Radius limitation
 - Slewing angle limitation
 - Edge limitation



The LICCON work planner

- Computer programme for planning, simulating and documenting crane operations on a PC
- Representation of all the crane's load charts
- Automatic search for suitable crane based on entry of load, radius and lifting height parameters
- Simulation of crane operations with outline functions and supporting force display

LICCON2 - safe and comfortable



Attaching and detaching of the hook block

The BTT Bluetooth Terminal offers the crane driver the possibility to attach or detach the hook block at the front of the vehicle within sight, as the hoist winch and the luffing cylinder of the telescopic boom are remote controlled.



Wireless remote control

Wireless remote control (option)

All crane motions can be controlled outside of the cab.

- Higher efficiency
- Free view and closeness to the load
- Prevention of communication errors between the crane driver and the job site personnel

Crane support

By use of the BTT the mobile crane will be setup comfortably and safely. Engine start/stop and speed regulation, electronic inclination display and automatic levelling are standard. Optionally the BTT can also display the outrigger forces.



Colour monitor

The readability of the data on the monitor of the LICCON2 control system in the crane cab is enhanced by the colour display. Warnings and crane utilization are considerably better recognized.



Touch displays

Below the joy sticks integrated in the armrests touch displays are installed, with which the various operational functions can be selected. These are beside others the drive and steering programs of the chassis, the axle suspension, the supporting of the crane, the adjustment of the working floodlights as well as heater and air condition controls.