

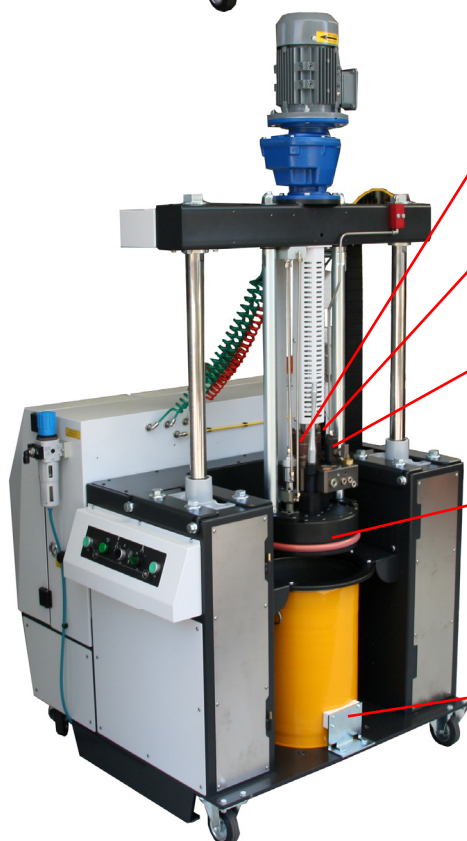

The Bulkmelter 20 Series melt on demand drum unloaders are intended for direct extrusion from drums of EVA based, Pressure Sensitive, Polyethylene, Polyamide, and Polyurethane adhesives and Mastics in general, for both manual and automatic applications. Designed for large-scale production, in order to meet the ever more sophisticated needs, they come in a 20 litre (5 gallon) configuration and are fitted with high pressure gear pumps with different flow rates and a safety valve, in order to guarantee absolute feed precision under all usage conditions, both continuous and intermittent. A new microprocessor controls all the operations necessary for the system to operate: thermo-regulation of the various sections, programming control of 8 glue lines for each of the 4 independent channels. Additional features include: Economy Function, Clock, Weekly Program, Maximum Absolute Temperature Alarm, sequential Heating for the various channels, and Temperature Set point Cut-out Delay. BM20 melters are innovative in terms of simplicity of use, production flexibility, maintenance operations and costs, quick installation, easy programming, safety standards, reliability, and complete integration with any existing packaging line, and guarantee maximum application versatility.

**LCD DISPLAY AND INNOVATIVE PROGRAMMING**

All the parameters involved in the correct functioning of the system are extremely simple to enter, program, edit, and set using the "Rotary Switch" selector. The new LCD Display depicts all sections of the machine and the related parameters graphically, making it extremely simple to programme the system, even for non-specialist personnel, without any problems with codes or foreign languages to be interpreted. A message area constantly and dynamically monitors the status of the system during the various operations. If any alarms or anomalies occur, appropriate error messages are displayed.

**ELEVATOR WITH PNEUMATIC CYLINDERS**

An elevator with two pneumatic cylinders for raising and lowering the heating pressure plate is used for changing the drum, which significantly reduces machine costs and down times due to refilling. The start cycle process is controlled by a two-hand activation system to ensure that the operator is totally safe and the refilling operation is then completed automatically once the flat pressure gasket is at the beginning of the drum. An automatic air discharge function simplifies drum changing operations.

**HIGH PRECISION GEAR PUMP**

The extruders are fitted with high precision gear pumps. Within the same size, pumps are available with flow rates that differ, depending on the adhesive used and the melt required. The pump is driven by alternating current motors, with variable electronic regulation and controlled by an inverter.

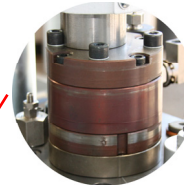
**REGULATION VALVE AND QUICK PRESSURE RELEASE**

This keeps the set pressure constant and guarantees maximum safety when the system is in use, by discharging the pressure in the adhesive in the system automatically and safely, even in an emergency.

**PRESSURE CONTROL DEVICE**

A sophisticated control system uses the melter's display to show the pressure of the adhesive at the manifold outlet. This display is similar to that for a traditional digital pressure gauge and shows the adhesive pressure in bars.

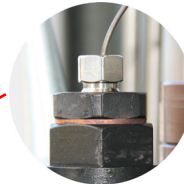
**PRESSURE PLATE WITH "ON DEMAND" MELTING SYSTEM**

A pressure plate only melts the quantity of adhesive required for the application, leaving the remaining material in a solid state. This on demand melting system makes it possible to protect and preserve the adhesive, reducing the risks of deterioration and cross-linkage, due to the product coming into contact with the air.

**DRUM CENTRING SYSTEM AND LEVEL SENSORS**

A centring system guarantees precise, accurate positioning of the drum, reducing waste to a minimum and allowing almost all the adhesive it contains to be used. The extruder is also fitted with a drum detection sensor, a level sensor that indicates when the drum is finished, and an optional second sensor that can be adjusted to indicate when the drum is running out.



**TECHNICAL SPECIFICATIONS**

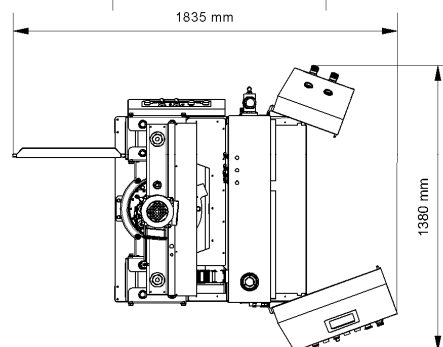
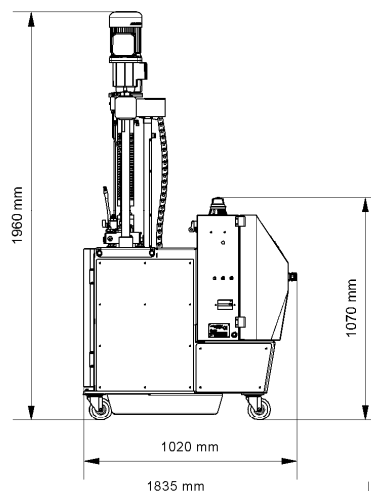
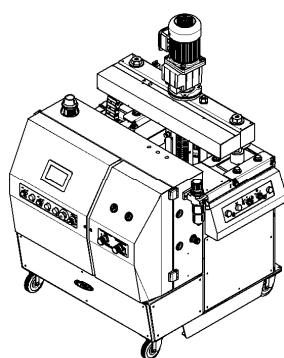
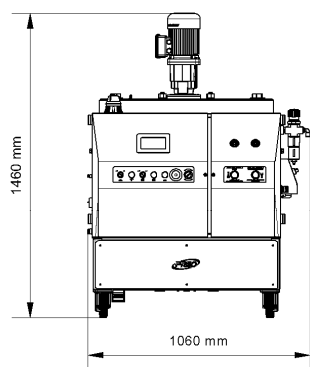

**GENERAL SPECIFICATIONS**

ADHESIVE TYPOLOGY AND VISCOSITY	Hot-melt polyamides and reactive polyurethanes (PUR) up to 100,000 Cps
DRUM INTERNAL DIAMETER	∅ 280 mm
OPERATING TEMPERATURE	50°C÷210°C (120°F÷410°F) standard version
HOSE/GUN CONNECTIONS	2, 4 (fitting thread 1/2"x20 UNF)
DRUM CAPACITY	20 lt (5 gallons)
MELTING RATE	16 kg/hr (depending on used adhesive)
WEIGHT (EMPTY)	290 kg (640 lb)
MACHINE DIMENSIONS (L x H x D MM)	1380 x 1960 x 1835 mm
PRESSURE PLATE	coated with PTFE scratch-resistant non-stick treatment,
MANIFOLD	coated with hard oxidation treatment and built-in glue filter
WARM-UP TIME	20 min starting from ambient temperature (0°C-45°C (32°F-113°F))

**ELECTRICAL SPECIFICATIONS**

VOLTAGE	1/N/PE AC 230 V ±10% 50/60 Hz, 3/N/PE AC 400 V ±10% 50/60 Hz
POWER CONSUMPTION	5,0 kW (23 A) (no hoses and guns)

**MICROPROCESSOR SPECIFICATIONS**

TEMPERATURE CONTROL	PT100 ±0,5°C (1°F) - RTD or Ni120 (by request)
MICROPROCESSOR TYPOLOGY	Graphic interface with 240x128 pixel back-lit LCD and rotary switch programming selector
FUNCTIONS	Economy, Clock, Weekly Program, Maximum Temperature Alarm, Sequential HeatingZones
SAFETY	by-pass safety valve, over-temperature automatic protection, emergency stop input alarm, automatic pressure release and flow rate regulation valve, drum detection sensor, drum running out level sensor, start cycle process with two-hand activation system
OPTIONS	integrated glue pattern control, dual control for drum running out (settable)

**GEAR PUMP SPECIFICATIONS**

PUMP TYPE	gear single flow
MAXIMUM PUMP SPEED	3,0-7,0 cc/rev (80 rpm)
MAXIMUM PUMP RATE	14 kg/hr (3,0 cc/rev pump) - 33 kg/h (7,0 cc/rev pump) (depending on used adhesive)
MOTOR SPECIFICATIONS	0,75 kW, variable speed, reduction gear 1:20, inverter controlled
MAXIMUM WORKING PRESSURE	55 bar

© Copyright 2011 PREO SRL - All rights reserved - Subject to change without advanced notice - Printed in Italy - Edition EN-140 BULKMELTER BM20 - 14/09/2011

**PREO S.r.l.**

Via Alessandro Volta, 7 • 20094 Corsico (MI) • Italia  
tel. (+39) 02 48601260 • fax (+39) 02 4503323  
www.preo.it • italia@preo.it • world@preo.it