

# Transformers

VOL 6 ISSUE 2 APRIL 2019

MAGAZINE

## INTERVIEWS:

Michael Rohde  
Carlos Jacomini  
Donald A. Bolin  
Ken Gao

## COLUMNS:

Market review  
Water in transformer  
Condition monitoring  
Supply chain management

## TECHNICAL ARTICLES:

Open-phase condition detection  
Innovative core and winding technology  
Dry HV insulation  
Power factor testing

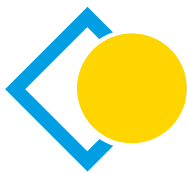

TRANS  
FORM 2019

Event HONG KONG  
Conference and Exhibition

September  
25 – 27, 2019

MEGACITIES –  
resilient solutions for  
electrical power supply.



ISSN 1849-3319

9 771849 331006



Expediting testing process ■ Born connected 2.0 ■ Oweld - reliable quality ■ Transport monitoring

**Combining high-performance materials with high-performance machines creates new value for transformer OEMs in terms of increasing the quality and efficiency of transformers**



**L.A.E. machines do not rely on the operators' experience to ensure a high quality of the product; the quality is guaranteed by the machine features**

# KEN GAO

## Senior Account Manager at Weidmann

### Combining materials and technology for high-quality and high-efficiency transformers

As the world leading supplier of insulation technology for key applications in the energy sector, Weidmann supplies high-quality insulation materials for transformers globally. L.A.E. Srl. supplies winding machines, core-cutting lines, and tank-manufacturing lines globally. L.A.E. machines are based on the latest technology that guarantees highest performance in transformers manufacturing.

L.A.E. has recognized the value of matching high-performance materials and high-performance machines. This concept creates new value for transformer OEMs in terms of increasing the quality and the efficiency of transformers. This idea was the cornerstone for establishing a cooperation between Weidmann and L.A.E. in the China market. The cooperation started at the beginning of 2018 and covers the promotion and distribution of L.A.E. products, namely winding machines, core-cutting lines, and tank manufacturing lines. Together, in October of 2018, we organized and participated in the 17<sup>th</sup> International Exhibition on Electric Power Equipment and Technology, the so-called EP China, in Beijing.

### Customers need better technology

Utilities in China, the SGCC (State Grid Corporation of China) and CSG (China Southern Power Grid), are increasing their requirements for transformer quality and efficiency. In order to respond to these new requirements, local OEMs have to improve their quality. They need to use high quality materials, but they also need to improve their production process. The production process is important to ensure that transformers can reach high quality and high efficiency. You can have the best material in the world but if you produce the transformer using low quality machines, that material can be destroyed. So, the combination of Weidmann and L.A.E. is very organic. At Weidmann, we supply high quality materials, and L.A.E. supplies high-quality and high-efficiency machines.

L.A.E. machines have a high level of automation and, in some case, they even use robotics. Robotics has become very popular in manufacturing in China because labor costs are drastically increasing. Automation is becoming more and more cost-effective and there is a very good payback when you invest in robotized manufacturing, even in

the transformers business. We need to be aware that only a few years ago the situation concerning labor costs here was quite different and it was difficult to foresee the current situation. Therefore, there is a high interest in L.A.E.'s machines among Chinese transformer manufacturers.

### Weidmann's high-performance Engineered Paper

Weidmann produces three types of advanced Engineered Paper, along with a full range of other insulation papers and materials. INSULutions® DPE (Diamond Pattern Enhanced) has thermal classes of 130 °C in mineral oil and 140 °C in natural ester. This, for example, means that INSULutions® DPE can be used in conventional transformers with

**Ken Gao** has been working in the transformer insulation industry for more than 15 years. He joined Weidmann in 2012 as an account manager with a focus on the distribution transformers market in China. He has an MBA degree from Shanghai University of Finance and Economics.

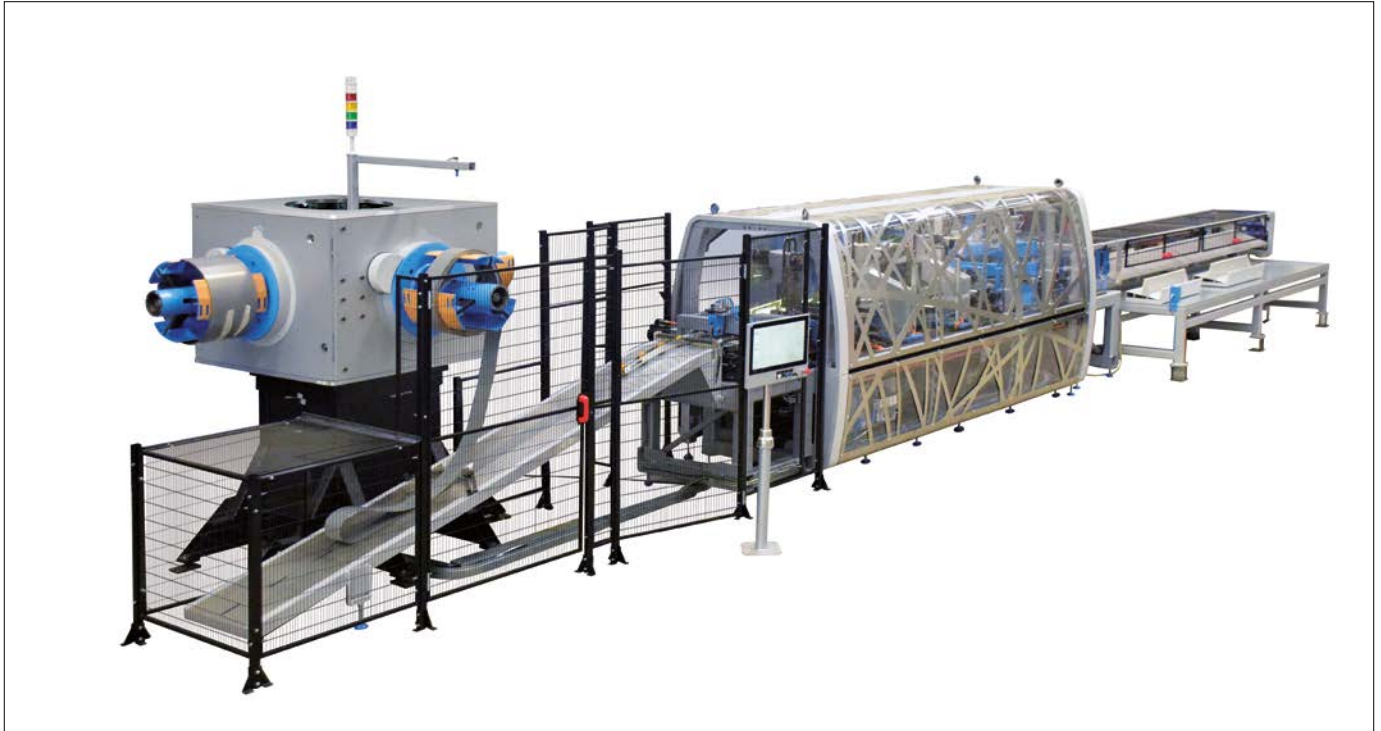

L.A.E. Core-cutting line TO 45



L.A.E. Coil winding machine BOB L 800

thermal class A and will have a longer lifetime. Given that INSULutions® DPE has higher electrical strength than traditional paper, by using DPE the OEM can reduce the thickness of layer insulation. INSULutions® DPE is available in thicknesses starting at 0.075 mm, and increasing to 0.38 mm.

So, by using INSULutions® DPE the transformer manufacturer can increase the thermal class of the transformer. They can also design a more compact transformer because the thinner INSULutions® layer provides the same dielectric strength as higher thickness traditional insulating paper.

INSULutions® DPE also reduces the production cost because its drying rate is 30 % faster than other cellulose paper. Additionally, its impregnation time is at least 25 % shorter when using both mineral oil and natural ester when compared to conventional paper. This is especially important for transformers filled with natural ester because the impregnation time in these cases is much longer than for transformers filled with mineral oil.

When higher mechanical strength is needed, Weidmann has another Engineered Paper called INSULutions® STRIP-Flex K. This paper is used for edge insulation and the graded insulation of windings.

Finally, Weidmann produces TUF-Flex® Engineered Paper. This is a very thin paper with great mechanical characteristics, especially the elongation which is approximately 20 %. This Engineered Paper is used for foil winding. TUF-Flex® can stretch but it doesn't break. So, one layer of 2 mm TUF-Flex can replace conventional paper of 3 mm. Taking into account the big number of turns, this is a huge difference. So, by using TUF-Flex®, the insulation thickness can be reduced by at least 30 %, and sometimes even 60 % when compared to traditional insulation.



L.A.E. Robot Stacker

## The productivity level and quality of L.A.E. machines ensures better ROI

All three types of Engineered Paper can be used with the L.A.E. machines. This is where the customer gets the advantage of combining Weidmann's high-quality paper and L.A.E.'s machines with high-quality technology. Together we can provide a total solution, supporting our customers by optimizing their insulation system design and the production process.

### L.A.E.'s total solution for manufacturing transformers

I have already mentioned the benefits of the paper, which contribute to a better transformer design. So, let me now explain the advantages of using L.A.E. machines from the point of view of the production process.

When it comes to the core-cutting lines, the L.A.E. machine has higher productivity. The initial higher investment cost can certainly be offset by increases in productivity that in some cases can be as much as 30 %. This means that transformer OEMs can get their investment back in a shorter time. The L.A.E. robot stacker can stack high-quality

core, which also helps to reduce transformer losses.

As an example, one customer wanted to buy the core-cutting line from the local supplier. However, they recalculated the cost and the productivity, along with the core quality, and since they needed high-quality production, a core-cutting line and a stacker, they decided to buy an L.A.E. machine instead. They realized that even with the more expensive machine they would, in the end, have a better process and that it made sense to invest more in the beginning to get more later on.

When we talk about winding machines, the price of local machines here in China is very low compared to the price on the international market. But the L.A.E. machine performance is much higher. It is

automated and very precise. Also, when using local low cost machines, you always needed experienced workers. L.A.E. machines do not rely on the worker for the quality of the product. Regardless of an operator's experience you get a winding of high-quality when it is manufactured using the L.A.E. machine. That is very important and it will become even more important in future.

### L.A.E.'s vision proved

Some manufacturers want to buy one machine and are convinced that the machine will work well and that the support from the manufacturer will be at a top class. Others will start with more than one machine. We are already finalizing agreements with our first customers and we have several inquiries for winding machines, tank-production lines, and the core-cutting line TO 45. This is the newest and most advanced type of machine with a robot for stacking the core. We have one customer who wants to order four TO 45 machines.

Then we have a customer who wants to set up a new workshop for manufacturing distribution transformers. It will be for a large production with a capacity of 20,000 transformers per year, and they want the total solution. They require foil-winding and wire-winding machines, core-cutting lines, etc. The large project requires 25 winding machines and one core-cutting line with the robot stacker. L.A.E. and the Trafogrid Alliance, in partnership with Weidmann, turned out to be the ideal partner for this project.

This proves that the people from L.A.E. were real visionaries when they got the idea to robotize the core-stacking process and when they realized it.

**By offering a total solution for transformer manufacturing jointly with the Weidmann and the Trafogrid Alliance, L.A.E. is an ideal partner for transformer manufacturers**

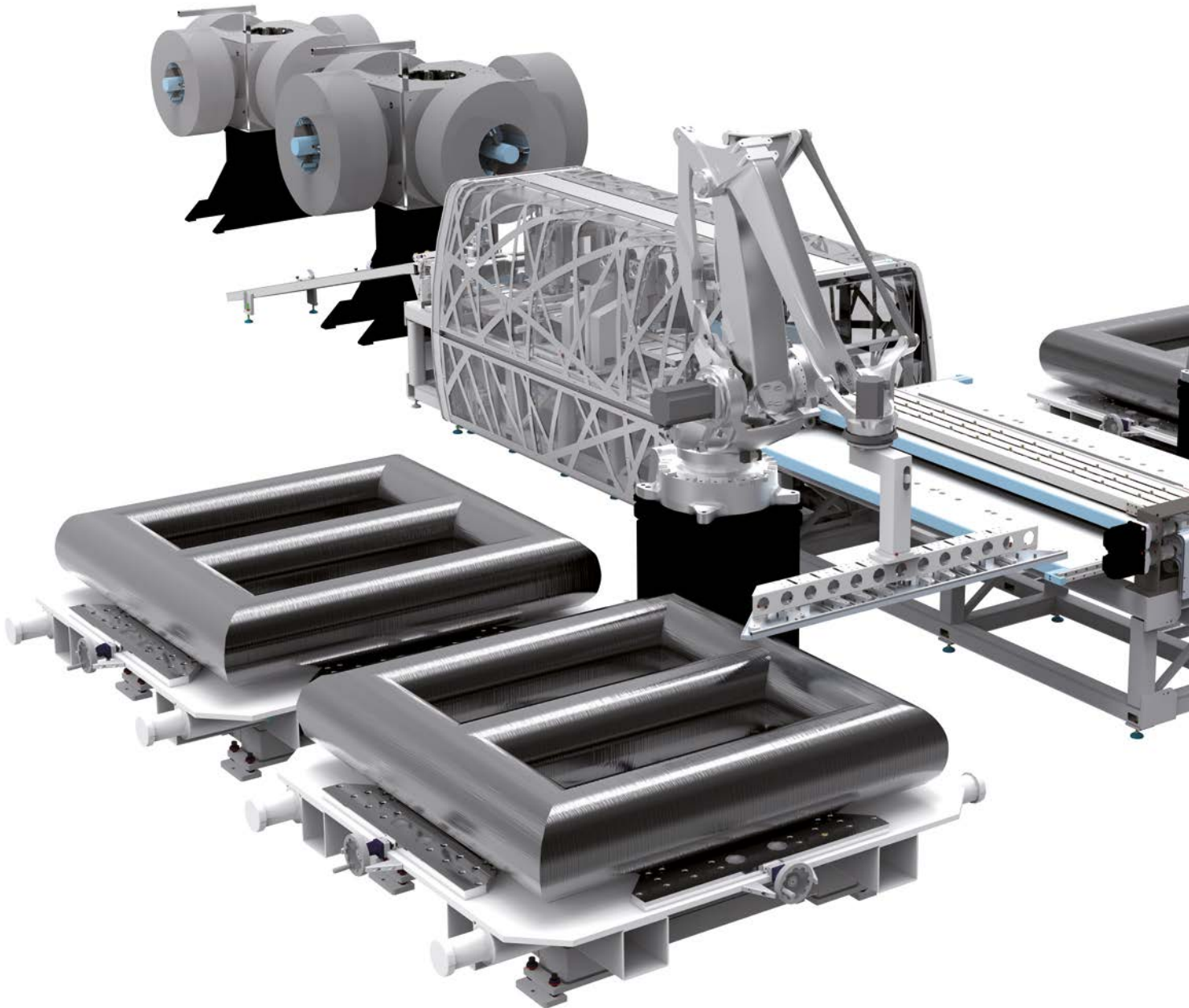

## ABSTRACT

Focusing on the real needs of the transformer core manufacturing process, the first step is to improve existing solutions and find new, innovative solutions at a whole process level, with the aim to produce highly efficient transformer cores in a both productive and competitive way.

The first innovative improvement concerns the automation of the stacking process, so far operated only manually, which can now be included in line with the core cutting process, thus responding to one of the major manufacturing issues: the productivity.

The second innovation refers to the automation of the lamination replacement into the cutting machine, thus

drastically reducing the average time for this operation from current approximately 10 mins to only 15 seconds, with significant improvement of the productivity, especially with different lamination widths.

The third major innovation concerns the core-filling factor of the distribution transformer. The current compromise between optimized shape and a minimum number of different widths of lamination, results in a core-filling factor ranging from 94 % to 96 %, using in general 7 to 11 different widths. Our revolutionary solution implies the use of octagonal shaped cores to reach a 99 % filling factor, with a significant saving on materials, and a correspondent improvement of no load losses (core losses), due to the extra 4-6 % of increased

material. This process patented (patent no. 102017000022419 [1]) under the name of TWINCORE exploits the optimized results from the unification of core cutting and stacking implemented by an inline slitting head, covering the entire production process with only 2 different sizes of mother rolls and using a single automated machine, thus avoiding intermediate storages and reducing lamination scrap.

Finally, the article will explore the optimization of the windings, resulting in a complete optimisation of the transformer's most crucial components.

## KEYWORDS

core, filling factor, losses, process, windings



**The current production of transformer stacked cores involves three different processes: slitting of core steel sheets, core cutting, and core stacking**

# Innovative solutions for distribution transformer cores and windings

## Improving the performance of distribution transformer through active part innovations

### Summary

The aim of this article is to offer the transformer manufacturers different solutions to improve the distribution transformer manufacturing process, especially regarding the active part of the transformer, focusing in particular on the core manufacturing process. This process, in fact, implies a high need of automation, due to its complexity and long time operations. The machine manufacturers shall therefore put their experience at the service of the transformer manufacturers and consequently, to end-users, such as utilities, in the name of constant quality improvement.

### 1. Introduction

The current production of transformer stacked cores involves three different processes: core slitting (i.e. longitudinal cutting of the lamination to obtain different widths from a single mother coil), core cutting (cut-to-length of single lamination according to required shapes and length as per core design) and core stacking, starting from a mother coil of grain-oriented silicon steel. This implies different machines and tools, consequent material moving from one process to the other, the need for storage systems, the employment of skilled operators and significant factory space. Moreover, this current production process

leads to considerable material scrap. All of the operations listed above are not always very well optimized, resulting in higher cost and lost time. In addition to this, the current core filling factor is a result of the compromise between an optimized shape of the core (usually round or oblong) and a minimum number of different widths of lamination. For distribution transformer, the filling factor usually ranges from 94 % to 96 %, with approximately 7 to 11 different lamination widths. These different laminations are manually loaded on the decoiler, Figure 1 and fed into the core cutting machine. Increasing the filling factor up to 99 % would certainly optimize the layout of the

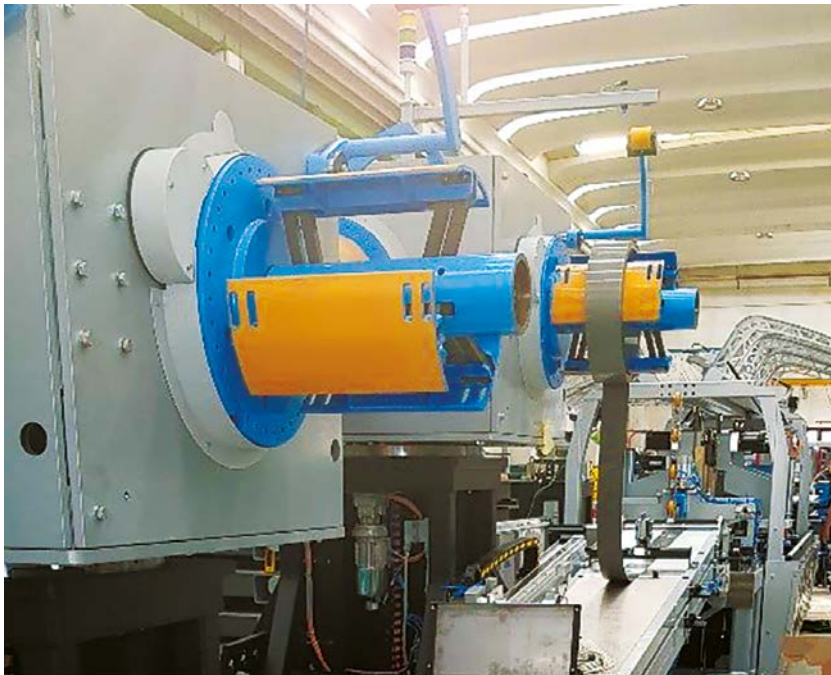

Figure 1. Decoiler

## Current technology requires different machines and tools, material moving from one process to the other, storage systems, the employment of skilled operators and significant factory space

active part and reduce the quantity of needed material, however, this would also imply the use of even more widths, processed in the way mentioned above.

Another aspect affecting both the transformers manufacturers' work and the utilities' needs, concerns the quality of the final manufactured product. It is estimated that approximately 20 % of the transformer failures are related to the core and magnetic parts of the transformer and 24 % is related to the windings (of a total 44 % related to the active part) [1]. Therefore, good quality can certainly reduce this failure rate and consequently ensure a longer life of transformers. Beside the use of the first choice material, equipment used for this important task can, of course, play an important role.

Last but not least, another concern of the transformer manufacturers or core service centers is related to the requirements set by the Eco design regulation

(European Directive 548/2014 [3]), in particular the TIER 2, the second step of this regulation which will come into force in 2021. Since the regulation's major objectives concerning transformer products implies significant reduction of the losses and the use of 0.23 mm steel, the machine manufacturer can prove once again to be transformer manufacturer's best ally, helping them successfully overcome this demanding challenge.

All these considerations take, of course, into the account the equipment which have been available so far. In order to meet the transformer manufacturers needs for optimization and to support them to reach the set goals of productivity and competitiveness, we have developed 3 different solutions concerning the core manufacturing process. They are as follows:

1. Automatic stacking system
2. Coil fast replacing system
3. TWINCORE

Moreover, the changes in the core manufacturing process also affect the optimization of the windings.

## 2. Automatic stacking system - in-line assembling and cutting

Transformers cores have usually been assembled manually and in general, separately from the core cutting process, resulting in material movement, use of several operators, different dedicated equipment and a need for storage. The automation of the core stacking and its inclusion in line with the core cutting process can certainly speed up the required operations and help to achieve the transformer manufactures biggest objective: increased productivity.

To achieve this result, the stacking process has been conceived in two major steps. The first step consists of a preliminary stack, prepared by each book of step lap laminations (generally a package of 10 to 12 laminations) and the second step, the final stacking of completely closed core or top open E type core, using a standard robotic solution available on the market.

The equipment is made of three main parts:

- a core cutting machine, which is made of a mandrel decoiler, centering guides, one or more punching units, V-Notch cutting unit, Figure 2, and a +45° / -45° swinging cutting shear
- a pre-stacking part, where the cut laminations are collected before being stacked into cores
- an anthropomorphic robot, Figure 3, or two anthropomorphic robots or two anthropomorphic robots in case we are using machines for larger transformer cores, assembling books of laminations (up to 12 laminations) into either closed cores or E-cores, with open top yoke (or even both bottom and top yoke left separated from the assembled legs). The robot assembles the cores on pallets, forming up to 4 three-phase or single-phase cores

The cores are formed on benches. Each bench is made of a base fixed on the ground and of an upper movable



Table 1. Results of the case study *Cutting and stacking over 20 cores/day automatically with low losses and only one operator/shift in a small space*

Executed by	L.A.E. Srl
Equipment used:	TO 25 with robot stacker
Number of operators	1
Transformer size	400 kVA
Laminations max. width	170 mm
Material used	M5T30
No. of step widths	6
Step lap	2 sheets/layer, 5 steps
Max. length	810 mm
Core weight	498 kg
Space	15x4=60 m <sup>2</sup>
Time per core	57'
Total cores per day (average)	20

**Our first innovative improvement concerns the automation of the stacking process, so far operated only manually, which can now be included in line with the core cutting process**

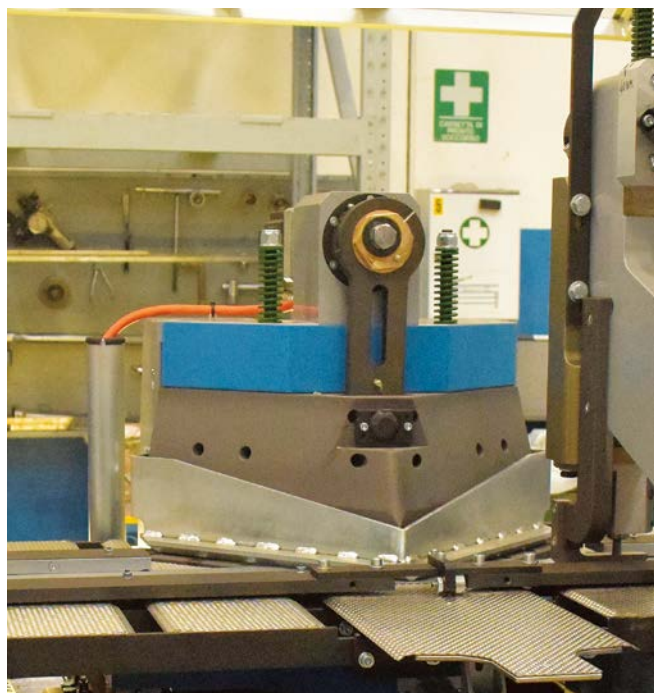

Figure 2. V-Notch

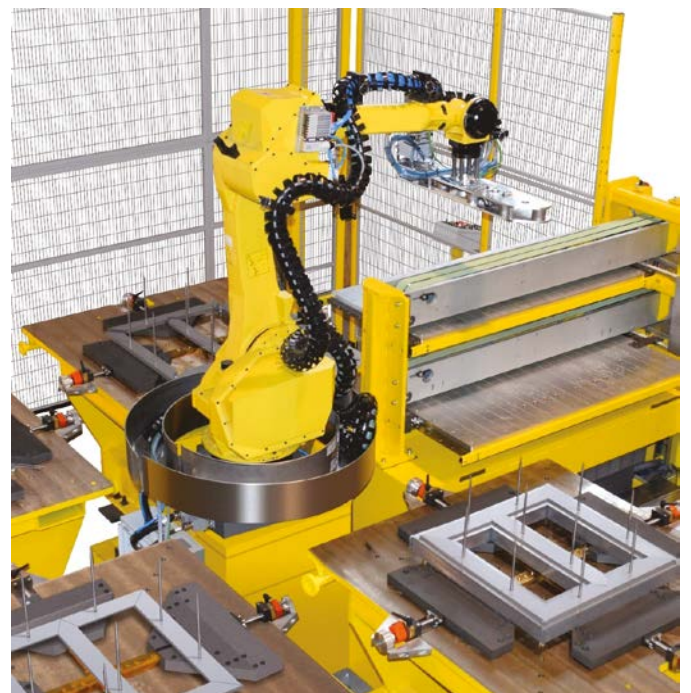

Figure 3. Anthropomorphic robot

structure (pallet), on which the operator can set up a structure used to compose the core. This movable structure can be removed from the base by a forklift or an overhead travelling crane.

The operators will just have to remove the ready cores, insert the windings and proceed with the process.

This automated solution has already been in use for 3 years and has proven consistent results, as shown in the case study in Table 1.

Beside productivity, this system can surely offer other important advantages such as: quality, compliment to TIER 2 requirements, space reduction, cost reduction.

a. Quality and TIER 2:

As mentioned in the introduction, one of the major issues affecting both producers and utilities is the quality of the cores. It is understood that a robot can offer more accuracy and a constant performance compared to a human being, thus ensuring a higher level of quality. Moreover, both the cutting machine and the robot can cut and stack 0,23 mm steel (or even 0,18 mm) thus fully complying with the TIER 2 of the regulation, thanks to a double feeder (i.e. pulling and pushing the lamination

at the same time, the same principle as a 4-wheel drive car) and control system.

b. Space reduction:

The compact layout of the machine (approx. 30 % of the layout reduction compared to a “traditional” core cutting line and related required assembly area) together with the advantage of having two parts of the process (cutting and stacking) combined in a single equipment, results into a consistent space reduction (the above shown case study had been carried out in 60 m<sup>2</sup> space).

c. Costs reduction:

The combination of cutting and stacking in the same process contributes to the reduction of waste, both in terms of scraps and non-compliant material. A constant performance provided by a robot staker, as men-

tioned before, can certainly ensure the achievement of specified high standards, contributing to the reduction of non-compliant products. In addition, especially in high cost labour countries, the use of a robot turns into interesting return of investment, as the number of required operators is massively reduced. The repetitive and long operation of the core assembling can therefore be performed by an anthropomorphic robot, leaving then the possibility to

appoint the operators to other less weary but more complex working tasks, where human abilities and talents are much more required.

**3. Coil fast replacing system: a way to use a larger number of widths without losing productivity**

Once the stacking and assembling process had been sped up by the implementation of an anthropomorphic

**The second innovation is the automation of the lamination replacement into the cutting machine, thus drastically reducing the time for this operation from approximately 10 mins to only 15 seconds**

Table 2. Cutting and stacking time calculation

		Power kVA	Foil thickness (mm)	Core Dimensions AxB (mm)	Weight (kg)	Core thickness D (mm)	Foil width min-max	Cut time + hand weav- ing (average approximate values)	Time for coil to finish upturned core min	Time reduction
1	TO 25	50	0,23	580x520	140	100	60-100	<b>1h 41min</b> (36min + 65min)	<b>51min</b>	-50 %
2		250	0,30	1020x1020	630	151	60-160	<b>2h 14min</b> (49min + 85min)	<b>1h 03min</b>	-53 %
3		400	0,30	990x1240	700	140	80-160	<b>2h 06min</b> (46 min + 80min)	<b>1h</b>	-52 %
4		630	0,30	730x890	740	222	70-170	<b>2h 52min</b> (67min + 105min)	<b>1h 23min</b>	-52 %
5		1000	0,30	790x980	940	246	70-190	<b>3h 15min</b> (75min + 120h)	<b>1h 29min</b>	-54 %
6	TO 45	1250	0,30	1520x1650	2430	230	120-260	<b>3h 31min</b> (91min + 120h)	<b>2h 19 min</b>	-34 %
7		1600	0,30	1580x1900	3230	255	130-280	<b>4h 34min</b> (104min + 170min)	<b>2h34min</b>	-44 %
8		2000	0,27	1720x2230	4300	276	140-300	<b>5h 39min</b> (129 min + 210min)	<b>3h 02min</b>	-46 %
9		3150	0,35	1660x1900	3500	267	130-280	<b>4h 24min</b> (94 min + 170min)	<b>2h 20min</b>	-47 %
10		6000	0,30	1410x1620	3600	307	150-330	<b>4h 48min</b> (118min + 170min)	<b>3h</b>	-38 %

robot, the choke point of the process remains in the loading of the coil, slowing down the productive potentials offered by the automatic stacking. It was, therefore, necessary, to find a solution which could smooth out the initial part of the process, i.e. coil loading and replacement. The second innovation involves the automation of the lamination replacement into the cutting machine, thus drastically reducing the average time needed for this operation from approximately 10 mins to only 15 seconds, with significant increase in productivity, especially with different lamination widths.

As mentioned before, the current core filling factor results from the compromise between an optimized shape of the core (usually round or oblong) and a minimum number of different widths of lamination. The distribution transformers filling factor usually ranges from 94 % to 96 %, using approximately 7 to 11 different lamination widths. Increasing the filling factor up to 99 % would certainly optimize the layout of the active part and reduce the quantity of needed material. On the other hand, this would also imply the use of even more widths, which are usually loaded manually on the decoiler, with the time of approximately 10 mins needed for this operation.

The automatic replacement of the lamination which lasts only 15 seconds, can, on one hand, improve the filling factor, and on the other enhance productivity.

The technical solution provided allows the replacement of the lamination inside the cutting line in 15 seconds in a full automated way. The system will take back the previous lamination width and insert the new one, according to the set program. These actions can be operated, on safety conditions, during the automatic functioning of the line.

Table 2 shows the time reduction obtained by the simultaneous use of both the robot stacker and the Fast Replacing System.

The above mentioned time calculation has been carried out considering

## The third major innovation concerns the core-filling factor of the distribution transformer

general transformer designs featuring the following conditions:

- Step lap package: 5 steps of 2 laminations each (total book of 10 laminations)
- Core made of 5 different lamination widths (for a total of 9 steps)
- 2 holes for each figure, made simultaneously with two punching units
- Use of Fast Replacing System FRS and robot stacker

### 4. Twincore: filling factor optimisation through a core shape change

The third major innovation relates to the core filling factor of distribution transformer. The current compromise between an optimized shape and a minimum number of different widths of lamination results in a core filling factor ranging from 94 % to 96 %, using usually 7 to 11 different widths.

This revolutionary solution implies the use of octagonal shaped cores to reach a 99 % filling factor, with a significant saving on materials. This process patented and registered under the name of TWINCORE exploits the optimized results from the unification of core cutting and stacking, implemented by

an inline slitting head, covering the entire production process with only 2 different sizes of mother rolls and using a single automated machine, thus avoiding intermediate storages and reducing lamination scrap.

#### Main principle:

- The machine will be able to cut from only 2 different widths of lamination, all required laminations for 1 to 2 transformers cores, stacking them automatically immediately after slitting and cutting, within the same process
- The shape of core legs will be octagonal, while the yok will be flat
- The 2 required strip widths will be:
  1. Equivalent to the largest width of the core (A)
  2. Equivalent to the

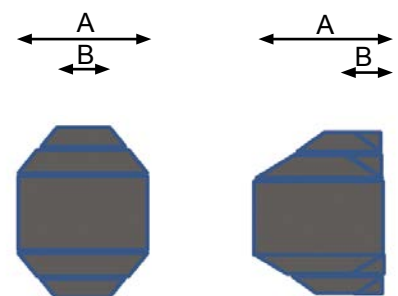

Figure 4. Octagonal core

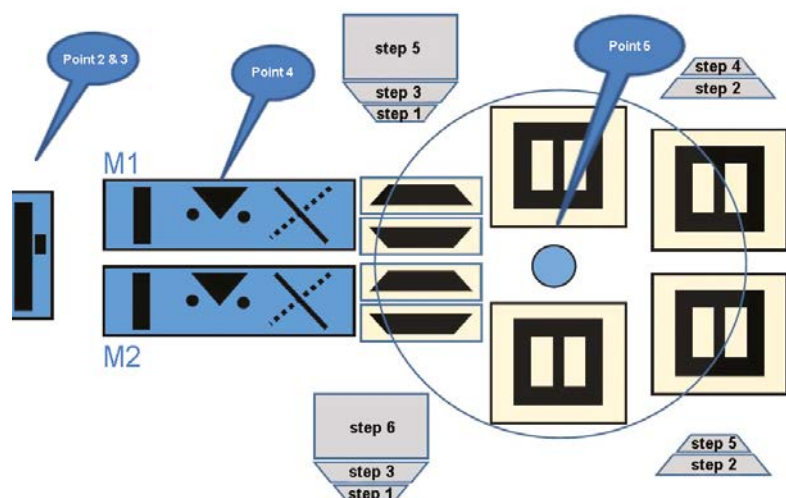

Figure 5. Twincore cutting line

Table 3. Case study for twine core concept

1	Manufacturing standards		IEC 60076-1	
2	Product type		Hermetically sealed transformer	
3	Service type /cooling method		Continuous service / ONAN	
4	Rated power	kVA	630	
5	Rated voltages	HV / LV (kV)	10 / 0.4	
6	Tapping range & No. of taps (HV. Off-load tap changer)		5 taps	±2 x 2.50 %
7	No. of phases		3	
8	Frequency	Hz	50	
9	Connection Group		Dyn 11	
10	No-load Losses	W	600	
11	Load losses	W	6500	
12	Impedance voltages (at 75°C and nom. pos.)	%	4 ± 10 %	
13	No-load current	%	1.8 + 30 %	
14	Max. ambient temperature	°C	40	
15	Temperature Rise			
	i) Windings	K	65	
	ii) Oil	K	60	
16	Core type		Core – Cold rolled grain oriented	
17	HV and LV windings		aluminum	
18	Tank cover		bolted	
19	Transformer dimensions			
	i) Width	mm	930	
	ii) Length	mm	1430	
	iii) Height	mm	1700	
20	Transformer weights			
	i) Total weight	kg	2590	
	ii) Oil weight	kg	620	
	iii) Active part weight	kg	1760	
21	Short circuit withstand duration	s	2	
22	Insulation levels		HV (kV)	LV (kV)
	i) One minute power frequency withstand voltage		28	3
	ii) Lightning impulse withstand voltage		75	-
23	Insulation class		Class A	

largest width of core + smallest width of core (A+B)

- The machine will increase productivity compared to standard solution, allowing the cutting of 2 laminations simultaneously most of the time

**Production line composition. The line will be formed by:**

- 1.3 decoilers, Figure 1, 1 for largest sum of lamination (A+B), 1 for largest core width (A)
- 2.1 slitting head with adjustable cutting width from A to B (see positions in Figure 2)
- 3.1 notching station for each different slitting width and automatic change
- 4.2 parallel and equal core cutting lines to cut largest width A each formed by:
  - feeder roller
  - 1 V-notching unit
  - 2 punching units and V-notch (longitudinally and transversally adjustable)
  - 1 swing shear
  - extraction and pre-stacking of the step lap books

5. Robot stacking unit with 4 stations to produce up to 2 cores at the same time

**Advantages:**

1. Doubled productivity due to the cutting of two pieces in parallel at the same time
2. Productivity increased by 10 % due to automated width change without reloading (total speed 220 % = 1 core 400 kVA every 40 mins instead of every 90 mins)
3. Increased filling factor to 99,5 % from actual average 94 % (corresponds to 5 % material saving or lower losses)
4. Flat yoke instead of circular one

(equal to other 5 % material saving or lower losses)

5. Reduced scrap of lamination due to automatic calibration of required thickness thus avoiding to cut more laminations for stacking which would be later scrapped (extra 2 % material saving)
6. Reduced stock of material to 2 widths only for each transformer design with possibility to standardize full range using only few different width
7. Reduced overall space of production avoiding any intermediate stock
8. Reduced operative personnel 2 people x 3 shifts to run the whole line instead of 6 people x 3 shifts (2 to

## The current compromise between optimized shape and a minimum number of different widths of lamination, results in a core-filling factor ranging from 94 % to 96 %, using in general 7 to 11 different widths

Table 4. Material saving with twincore concept.

	630 kVA Round		630 kVA Oblong		630 kVA Octagonal	
	Weight	Cost Dollar	Weight	Cost Dollar	Weight	Cost Dollar
Low voltage	107.6	341.1	99.1	314.2	99.3	314.7
High voltage	166.8	587.0	161.6	568.8	162.2	571.1
Core	789.0	2603.7	747.2	2465.8	679.1	2241.0
Oil	437.0	481.2	362.0	398.6	273.0	300.6
Tank	308.2	335.8	276.0	299.6	225.1	243.4
Risers	7.1	14.3	6.5	13.1	8.2	16.6
Active part	1070.5	3531.8	1014.4	3348.8	948.8	3126.8
Total (kg)	1815.6	<b>4363.2</b>	1652.4	<b>4060.2</b>	1447.0	<b>3687.4</b>

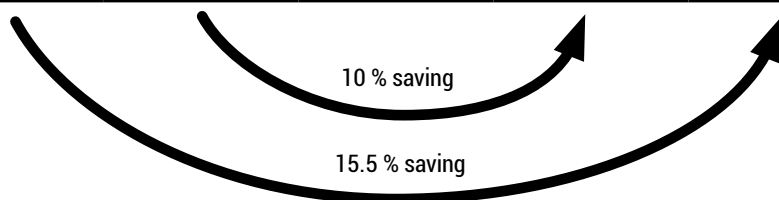

# Our revolutionary solution implies the use of octagonal shaped cores to reach a 99 % filling factor, with a significant saving on materials, and a correspondent improvement of no load losses

run the 2 machines + 4 as 2 per each table to assemble core manually)

- 630 kVA 10-0,4 kV transformer according to TIER I as per Eco design regulation (European Directive 548/2014) was designed as three alternatives; with **round**, **obround** and **octagonal** cores and windings.
- All designs were done with a design programme under same technical (insulation distances, raw material dimensions, formulas etc.) and commercial (raw material availability, raw material prices etc.) conditions.
- All designs are made according to latest design programme algorithm. Comparison is shown in Table 4.

Because of high core filling factor (around 99 %), the core is much more compact in octagonal design than in round and oblong designs. Since in general, octagonal transformer design is much more compact than other designs, in all parts (active part, oil tank, core) there is considerable cost saving. Therefore, from oblong to octagonal, there is about 10 % saving, whereas from round to octagonal there is around 15 % cost saving.

## 5. Windings

To contribute to the benefits obtained by the changes on the core, the windings will be different from the

traditional round shape and will be oblong, rectangular or octagonal.

All starts from the design:

- The shift from round to oblong allows significant material saving (around 10 % to 15 %) even if winding must be more compact to resist short circuit forces. Accurate tension is needed
- Use of foil for LV windings: today's technology allows the use of LV foil winding up to 20 or 40 MVA transformer, resulting in higher productivity and better quality coils which compensates well for any extra costs regarding material
- Wire flattening with HV windings, allows the decrease of space factor thus further allowing more compact coils
- Use of graded insulation on HV windings instead of full width insulation, allowing a better tension by putting insulation only where it is needed

Of course, this optimized design requires the use of adequate equipment.

Table 5. New winding design vs traditional winding design

400 kVA 20 / 0.4 kV	TRADITIONAL DESIGN, Figure 4 - Round wire - Full width insulation	NEW DESIGN, Figure 5 - Flattened wire - Gradual insulation
Core weight	507.6 kg	468.7 kg
HV winding	153.6 kg	147.0 kg
LV winding	106.4 kg	98.5 kg
Tank and cover	158.0 kg	154.0 kg
Oil	210.0 kg	190.0 kg
Other	172.4 kg	161.8 kg
<b>TOTAL</b>	<b>1308 kg</b>	<b>1220 kg</b>

Saving in weight:  $(1308 - 1220) / 1308 = 6.73 \%$

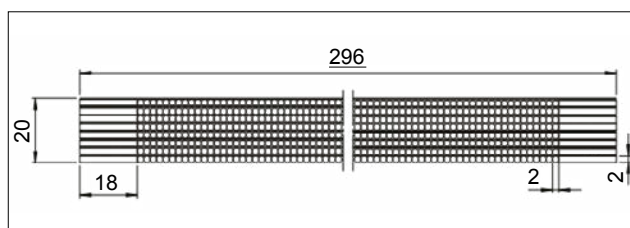

Figure 6. Traditional winding design

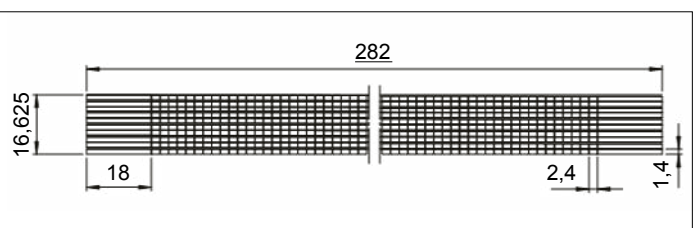

Figure 7. New winding design

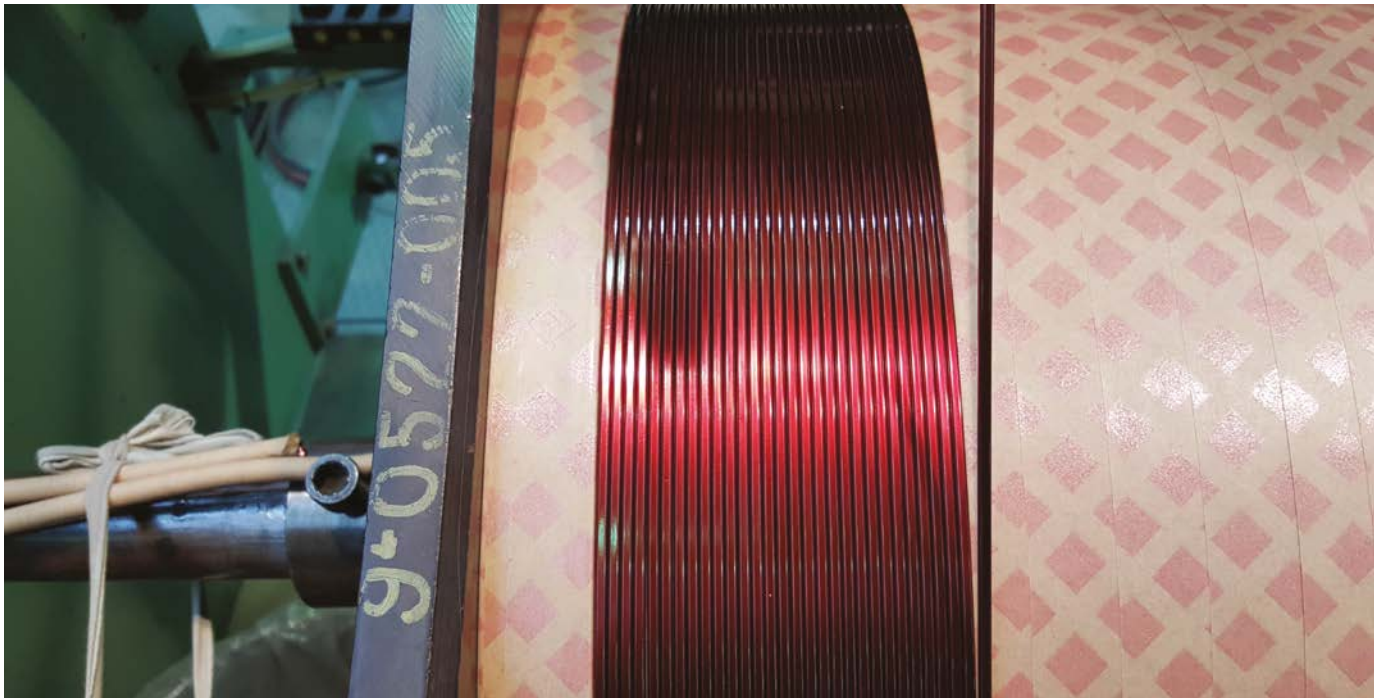

Figure 8. Winding featuring 4-way flattened wire and graded insulation

## Changes in the core manufacturing process enabled us to also optimize the winding manufacturing process

Winding on non-round shapes implies the need of a perfect tensioning control system, be it on the foil or on the wire. This control system has been developed by few companies both for LV foil winding machines (where the alignment of the foil is also controlled) and for HV wire winding machines, thanks to the electronic control system, permitting reduced tolerances and a perfect result on non-round shape as well, in terms of compactness and productivity. The regenerative braking system, applied on the foil winding machines, saves energy, which is perfectly in line with the current focus on the environment.

Moreover, the use of flattened wire and graded insulation on HV windings can give interesting outputs, as shown in the case study in Table 5.

### Conclusion

Starting from real needs of the customers, looking at the entire manufacturing process and keeping an innovative approach is the best way to not only support the industry needs but also to keep up with the technology without restricting changes. This will ensure

constant evolution of both the manufacturing process and the technology implied. Technological innovation has to serve people's actual needs, not only to support our business partners' achievements, but also to improve the working conditions, relieving human beings of repetitive and wearing operations - which can easily be performed by a robot - and to contribute to a less polluted environment, reducing the losses and supporting the production of clean energy.

### Bibliography

- [1] Patent no. 102017000022419 dated November 26, 2018, owned by L.A.E. Lughese Attrezzature per l'Elettromeccanica Srl
- [2] F. Hillmann, *Transformer Damages from an Insurance Providers Point of View*, 11<sup>th</sup> Transformer Life Management Conference, 2017
- [3] Ecodesign regulation (European Directive 548/2014) for Small, Medium and Large Power Transformers

### Author



**Ales Bertuzzi** has been working in the transformer industry since 1989. After completing his education at a professional high school, he started working in the family owned company, L.A.E. Lughese Attrezzature per l'Elettromeccanica S.r.l, in Lugo (ITALY), first working at the workshop. He was then promoted to sales manager, thanks to his language skills and his interest in marketing and negotiations.

He expanded the company's business to international markets, making L.A.E. a worldwide brand and significantly increasing the turnover over the years. His commitment and forward-looking attitude contributed to turning L.A.E. into a modern and a dynamic company.

In 2008 L.A.E. was acquired by a foreign holding, which entrusted him with the current role of Managing Director.