



8 2 0 N O V A m V

MULTIFUNCTIONAL CONTROL FOR GAS



THERMOPILE POWER SUPPLY

THERMOELECTRIC SAFETY DEVICE

SERVO-CONTROLLED PRESSURE REGULATOR

SHUT-OFF SOLENOID VALVE



SINGLE-KNOB MULTIFUNCTIONAL CONTROL

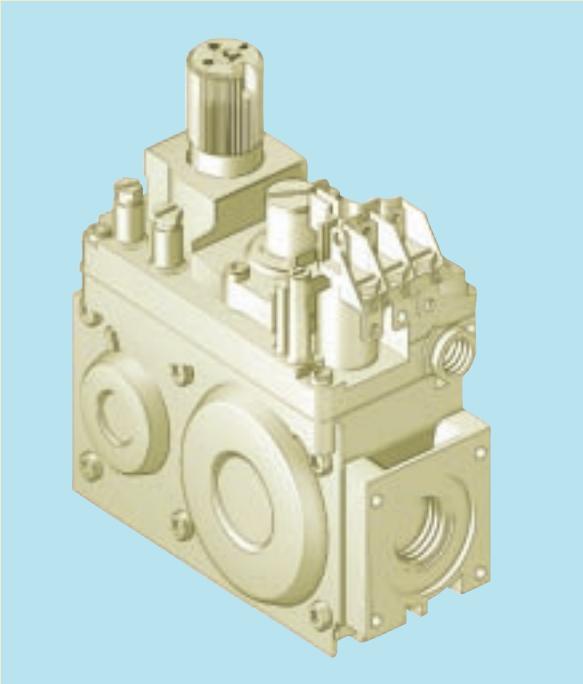

820 NOVA mV is suitable for installation on boilers, catering equipment, furnaces and radiators where complete independence from the external electricity mains supply is required.

Multifunctional control with shut-off solenoid valve powered by a thermopile: an external power supply is not required. Fitted with: thermoelectric safety device, single control knob (off, pilot, on), restart interlock against improper operation, servo-controlled pressure regulator, and shut-off solenoid valve with on/off gas flow control.

Step ignition device on request.

MAIN FEATURES

- Thermopile power supply.
- Three position (off, pilot, on) control knob.
- Thermoelectric flame failure device with restart interlock.
- Near-silent automatic shut-off valve.
- Servo-controlled pressure regulator.
- Step ignition device (optional).
- Main gas flow manual adjustment device (on request).
- Pilot outlet with gas flow restrictor.
- Inlet and pilot filters.
- Inlet and outlet pressure test points.
- Threaded gas inlet and outlet with provision for flange connection.
- Connection for pressure regulator / combustion chamber compensation.

Data refer to EN 126

DESCRIPTION

- | | |
|--|---|
| <ul style="list-style-type: none"> 1 Control knob 2 Main gas flow manual adjustment device 3 Adjustment screw for gas flow to the pilot 4 Thermocouple connector 5 Alternative thermocouple connector 6 Provision for accessories support bracket 7 Inlet pressure test point | <ul style="list-style-type: none"> 8 Outlet pressure test point 9 Actuating solenoid valve 10 Pilot outlet 11 Main gas outlet 12 Holes (M5) for fixing flanges 13 Supplementary valve body fixing points 14 Connection for pressure regulator / combustion chamber compensation 15 Thermopile and thermostat connection |
|--|---|

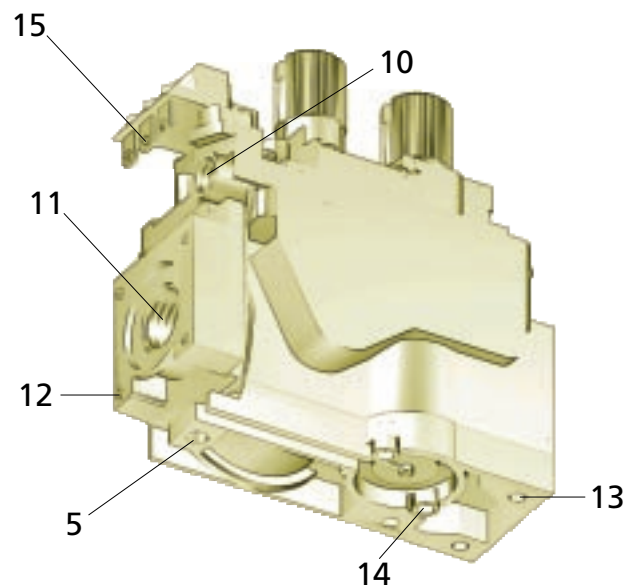
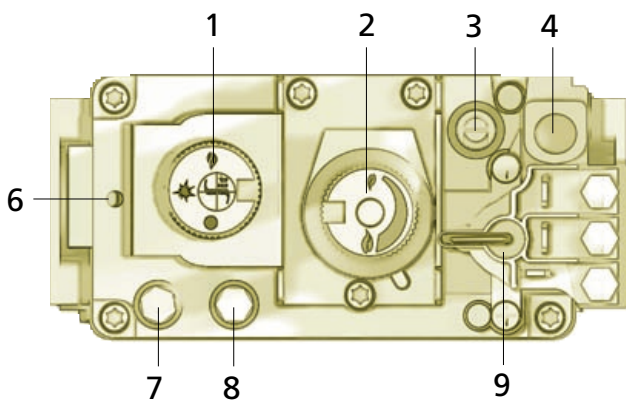

TECHNICAL DATA

- | | |
|--|---|
| <ul style="list-style-type: none"> • Gas connections: • Installation position: • Gas families: • Maximum gas inlet pressure: • Outlet pressure setting range: • Working temperature range: • Pressure regulator: • Automatic solenoid valve: | <p>Rp 1/2 ISO 7 (1/0 3/8" on request)
any position
I, II and III
60 mbar
3...30 mbar (20...50 on request)*
0...70 °C
Class B
Class D (Class C on request)</p> |
|--|---|

* Versions without manual gas flow adjustment device

THERMOPILE POWER SUPPLY

Use two-wire thermopile

Voltage with open circuit	≥ 350 mV
Voltage with closed circuit	≥ 100 mV
Resistance of the coil	1.6 ohm

Data refer to EN 126

Visit www.PartsFor.com for more Information



DIMENSIONS

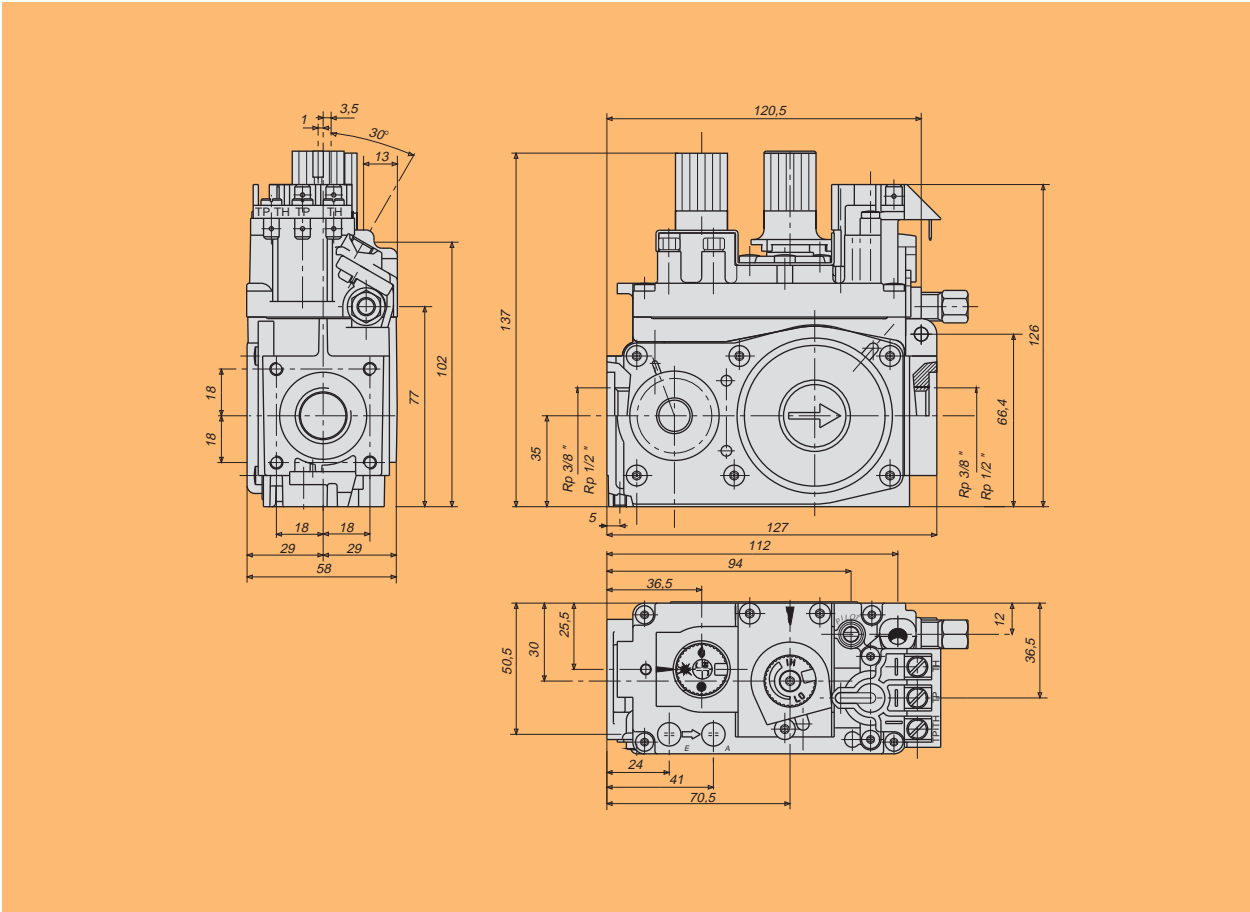

FLOW RATE AS A FUNCTION OF PRESSURE DROP

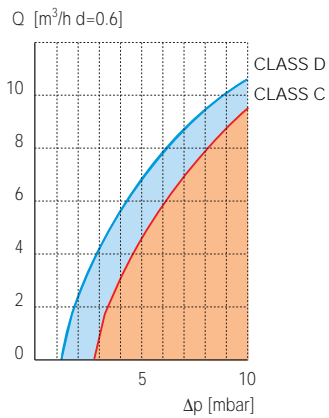

CLASS D

I Family	(d = 0.45)	Q = 7.5 m ³ /h	Δp = 5 mbar
II Family	(d = 0.6)	Q = 6.5 m ³ /h	Δp = 5 mbar
III Family	(d = 1.7)	Q = 8.1 kg/h	Δp = 5 mbar

CLASS C

I Family	(d = 0.45)	Q = 5.3 m ³ /h	Δp = 5 mbar
II Family	(d = 0.6)	Q = 4.6 m ³ /h	Δp = 5 mbar
III Family	(d = 1.7)	Q = 5.8 kg/h	Δp = 5 mbar

OPERATION

Pilot flame ignition

Depress and turn the control knob to the pilot position .
Depress the button and ignite the pilot flame while keeping the knob fully depressed for a few seconds (fig. 1).
Release the knob and check that the pilot flame stays lit. If it goes out, repeat the ignition operation.



fig. 1

Main burner ignition



Depress and turn the control knob to the "on" position  (fig. 2).
When the automatic solenoid valve is energized, gas passage to the main burner is opened.
Valves with step ignition devices reach the maximum flow after about 10 seconds.



fig. 2

Pilot position

To keep the main burner closed and the pilot flame lit, depress and turn the control knob to the pilot position .

Turning off

Depress and turn the control knob to the "off" position  (fig. 3).

Caution: the restart interlock device prevents ignition of the appliance until the flame failure device has stopped gas flow. At the end of this period (after closing the magnet unit) it is possible to carry out the re-ignition operation.



fig. 3

REGULATED FLOW RATE IN ACCORDANCE WITH EN 88

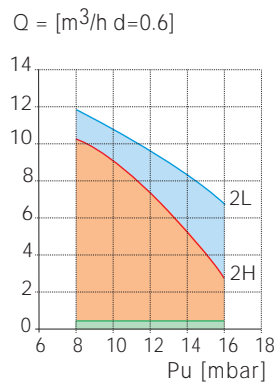

CLASS C

Gas type	Inlet pressure range		
	Nominal	Max.	Min.
2H	20	25	17
2L	25	30	20

Outlet pressure tolerance +10%...-15%

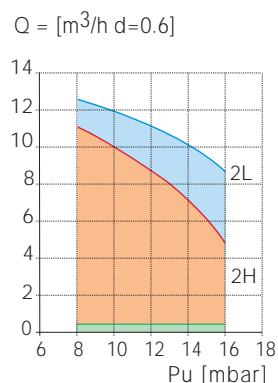

CLASS D

Gas type	Inlet pressure range		
	Nominal	Max.	Min.
2H	20	25	17
2L	25	30	20

Outlet pressure tolerance +10%...-15%

INSTALLATION

Main gas connection

The connection is made using gas pipes with Rp 1/2 ISO 7 threading. Torque: 25 Nm. If, alternatively, flanges (available on request) are used, first screw the pipes onto the flanges and then the flanges to the valve. Recommended torque for the flange fixing screws: 3 Nm.

Connection to the pilot burner

Pipes with Ø 4 mm, Ø 6 mm or Ø 1/4 can be used. Use a nut and olive of appropriate dimensions. Tighten the nut to 7 Nm torque.

Connection to the combustion chamber

Pressure regulator / combustion chamber compensation is possible when the latter is pressurized (see figure).

Use the special SIT hose connectors for this purpose. Torque: 1 Nm.

Electrical connections

Use the special connectors for connection to the thermopile and to the thermostat.

Make the connections in accordance with the plan below and in accordance with the rules for the appliance.

The electrical safety cut-off devices (for example, the flame failure device, limit thermostat, and the like) must cut off the power supply to the thermoelectric circuit of the safety magnet unit.

Caution: after making the connections, check gas tightness.

WIRING PLANS

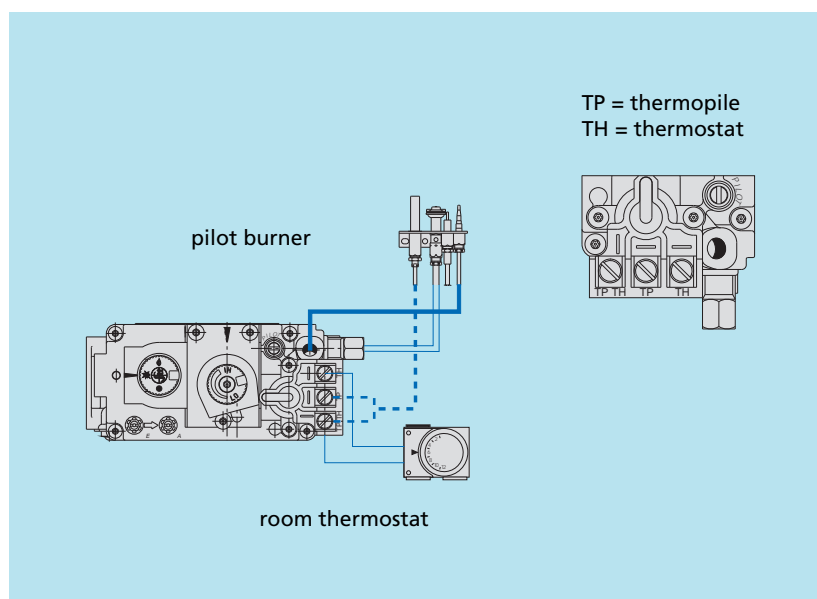

SETTINGS AND ADJUSTMENTS

Measurement of the inlet and outlet pressure

The inlet and outlet pressures of the gas can be measured by unscrewing the provided test point sealing screws.



Replace screws with 2.5 Nm torque.

Outlet pressure adjustment

Versions without manual gas flow adjustment device (fig. 1).

Remove the protective plug (A), and screw in the adjustment screw (B) to increase the outlet pressure or screw it out to reduce it. Having made the setting, fit the plug (A) flush.

Versions with manual gas flow adjustment device (fig. 2).

The adjustment is made by turning the knob (E) on which the symbol  corresponds to the maximum pressure to the burner and  corresponds to the minimum pressure. Actuation of this knob is independent from actuation of the control knob.

Overriding the pressure regulator

Replace the plug (A), the adjustment screw (B) and the spring (C) with the accessory (D), code 0.907.037. Torque: 1 Nm.

Gas flow-rate adjustment to the pilot

Screw in the associated screw to reduce the flow or unscrew it to increase flow.

Overriding gas flow-rate adjustment to the pilot

It is sufficient to screw the adjustment screw in flush and then screw it out two complete turns.

Changing the gas family or group

Check suitability for use with the gas family or group of interest.

Following the instructions given above, adjust the outlet pressure to the values indicated in the instruction booklet of the appliance.

If required: override the pressure regulator and gas flow adjustment to the pilot.

CAUTION:

Check tightness and efficiency and seal the adjustment devices.

Implement the provisions in the Use and Maintenance manual - code 9.956.820 - for installation, adjustment and use.

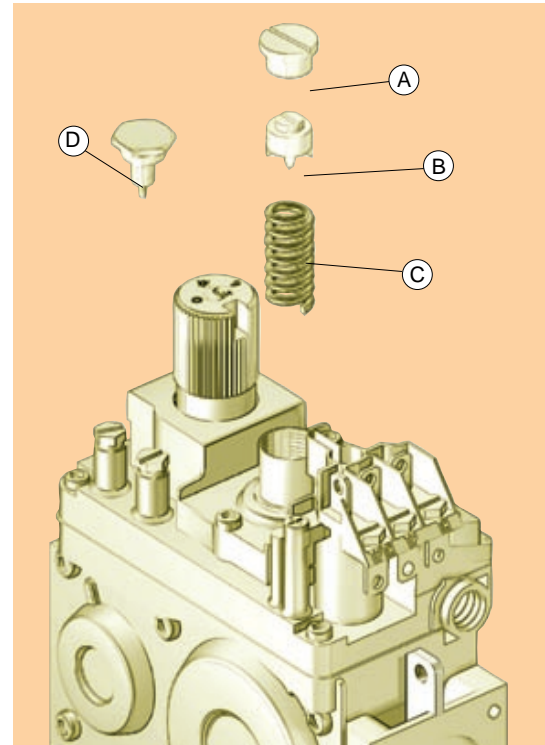

Fig.1 - Outlet pressure adjustment

Versions without manual gas flow adjustment device

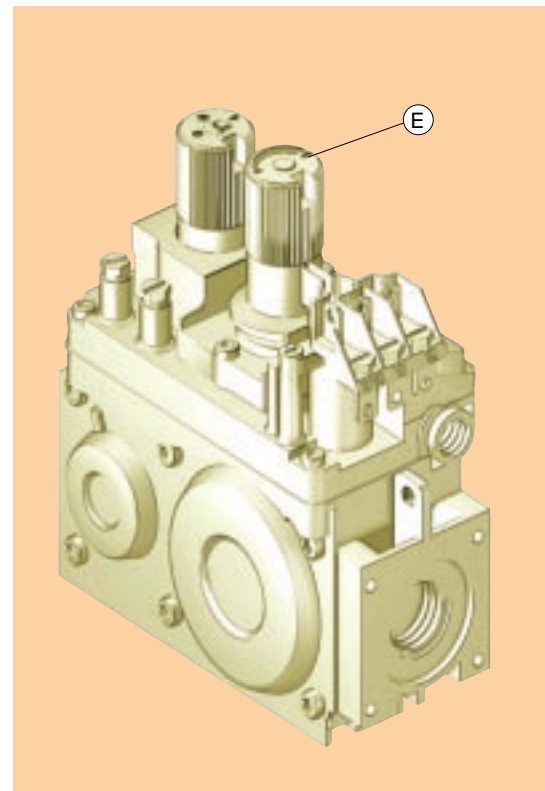
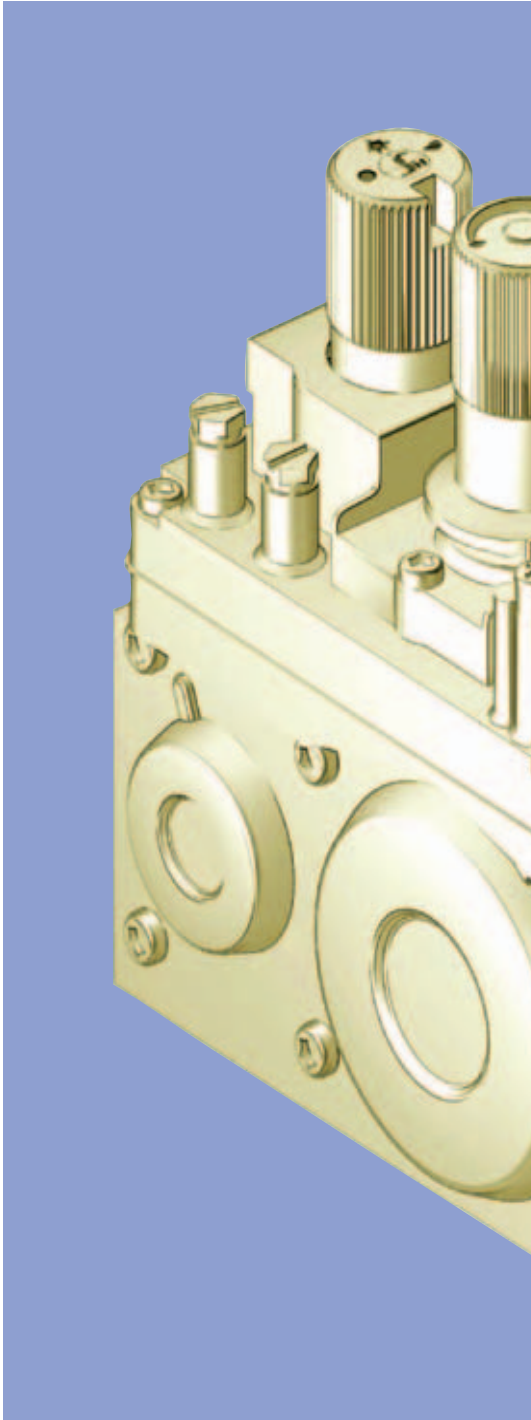
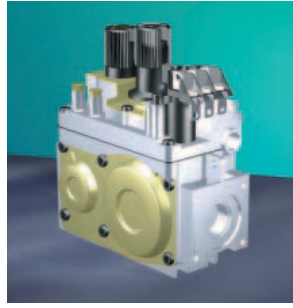

Fig.2 - Outlet pressure adjustment

Versions with manual gas flow adjustment device



820NOV A mV



**Multifunctional control
for gas appliances
without electrical power
supply.**



SIT La Precisa S.p.A.
Viale dell'Industria 31-33
35129 PADOVA - ITALY
Tel. +39/049.829.31.11, Fax +39/049.807.00.93
www.sitgroup.it - e-mail: mkt@sitgroup.it

Visit www.PartsFor.com for more Information