

# BREAKING THE EFFICIENCY FRONTIER - A NEW ORC TURBINE



The Industrial Technology Research Institute of Taiwan (ITRI), a leader in the Taiwanese High Tech and Clean Energy Research initiatives, has partnered with SoftInWay on a major new undertaking: to break the efficiency frontier and develop a new and innovative type of ORC Turbine. The overall goal of creating this new ORC Turbine is to deliver a superior solution to the heating Alternative Energy Generation market.

## TASK FORMULATION: ORC POWER UNIT DESIGN

The turbine design has been determined as an axial turbine with radial inflow inlet scroll duct, axial outlet tail pipe and an integrally bladed disk configuration.

### OBJECTIVES

- Turbine isentropic efficiency: >80%
- Turbine shaft power: >250kW
- Off-design turbine isentropic efficiency:  $\geq 70\%$  for  $\pm 10\%$  of point rotational speed.

### TURBINE DESIGN PARAMETERS

- Mass flow rate: 11.58 kg/s
- Inlet total pressure: 1260 kPa
- Inlet temperature: 101°C
- Outlet static pressure: 250 kPa
- Shaft rotational speed: 12000 rpm
- Work fluid: R-245fa refrigerant

### PROJECT CONSTRAINTS

- Turbine rotor tip diameter: 200 - 400mm
- Axial thrust: 4700 N

## ORGANIC RANKINE CYCLE (ORC) OVERVIEW

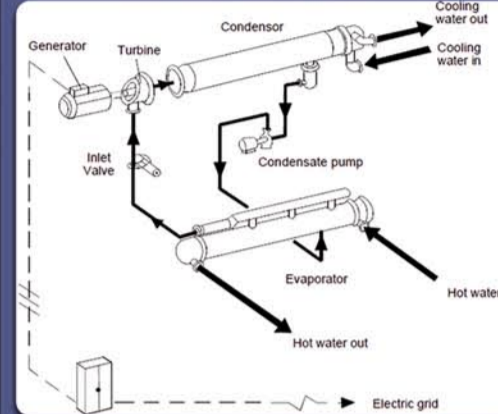

The ORC applies the principle of the steam Rankine cycle, but uses organic working fluids with low boiling points to recover heat from lower temperature heat sources (biomass, geothermal, waste, etc).

ORC Unit Main Elements

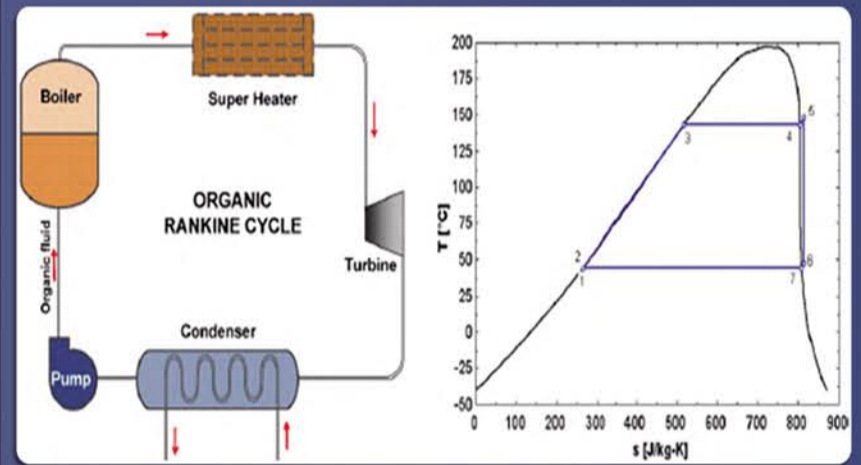

ORC configuration and process

## LEVERAGING AxSTREAM™ FOR BLADE AND FLOW PATH DESIGN

### AXIAL TURBINE FLOW PATH DESIGN

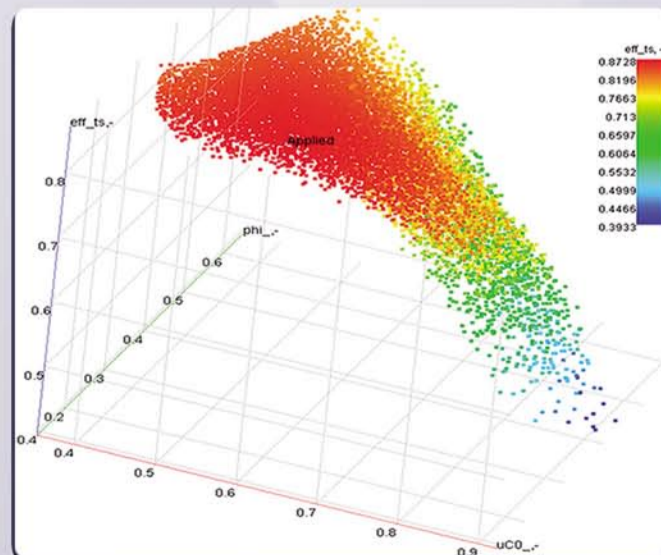

### FLOW PATH ANALYSIS AND OPTIMIZATION

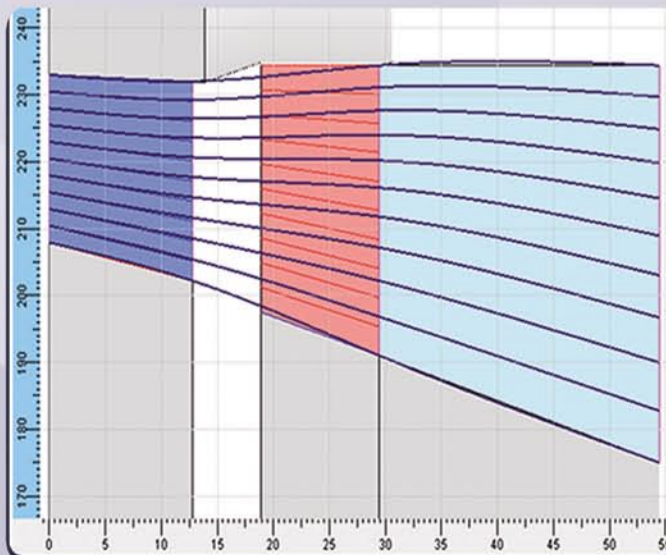

### BLADES AND NOZZLES 3D DESIGN

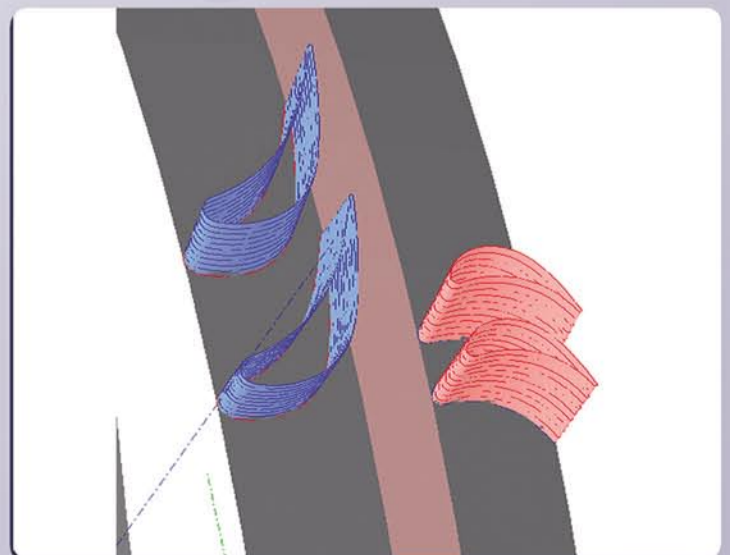

# BREAKING THE EFFICIENCY FRONTIER - A NEW ORC TURBINE



## 3D SOLID MODELING

As an important part of the overall design process, 3D solid modeling and analysis of the auxiliary turbine elements were performed in the following steps:

BLISK STRUCTURAL AND MODAL ANALYSIS

BLISK 3D DESIGN

OUTLET DEVICES 3D SOLID MODELING

INLET DEVICES 3D SOLID MODELING

3D Solid Model

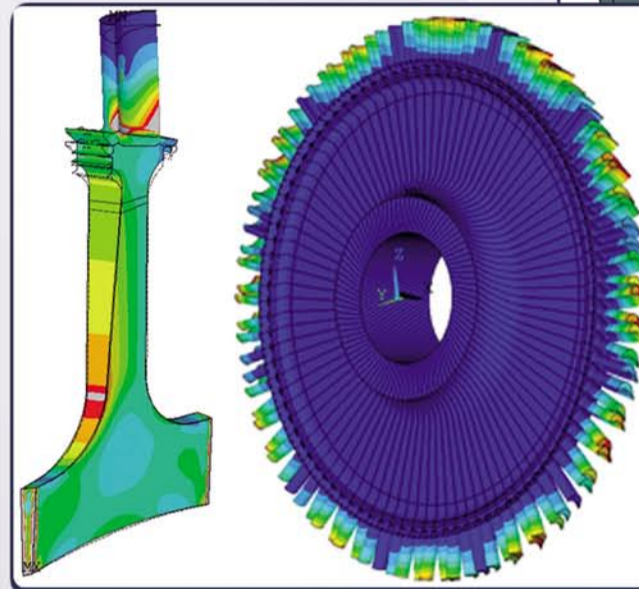
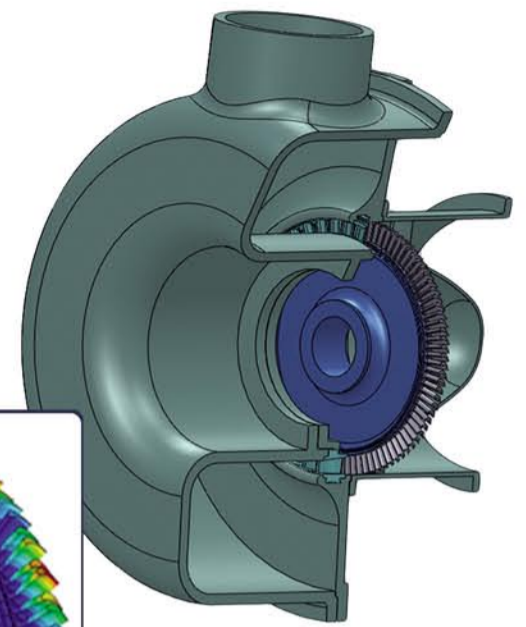

Blisk Structural Analysis



## MISSION ACCOMPLISHED

✓ Blisk shape optimization for structural and manufacturing efficiency

✓ Total-to-static efficiency: 81.77% (over 1% more than requested)

✓ ORC unit power: 253.14 kW (1.3% higher than required)

✓ Controlled reaction design to satisfy customer axial load requirements

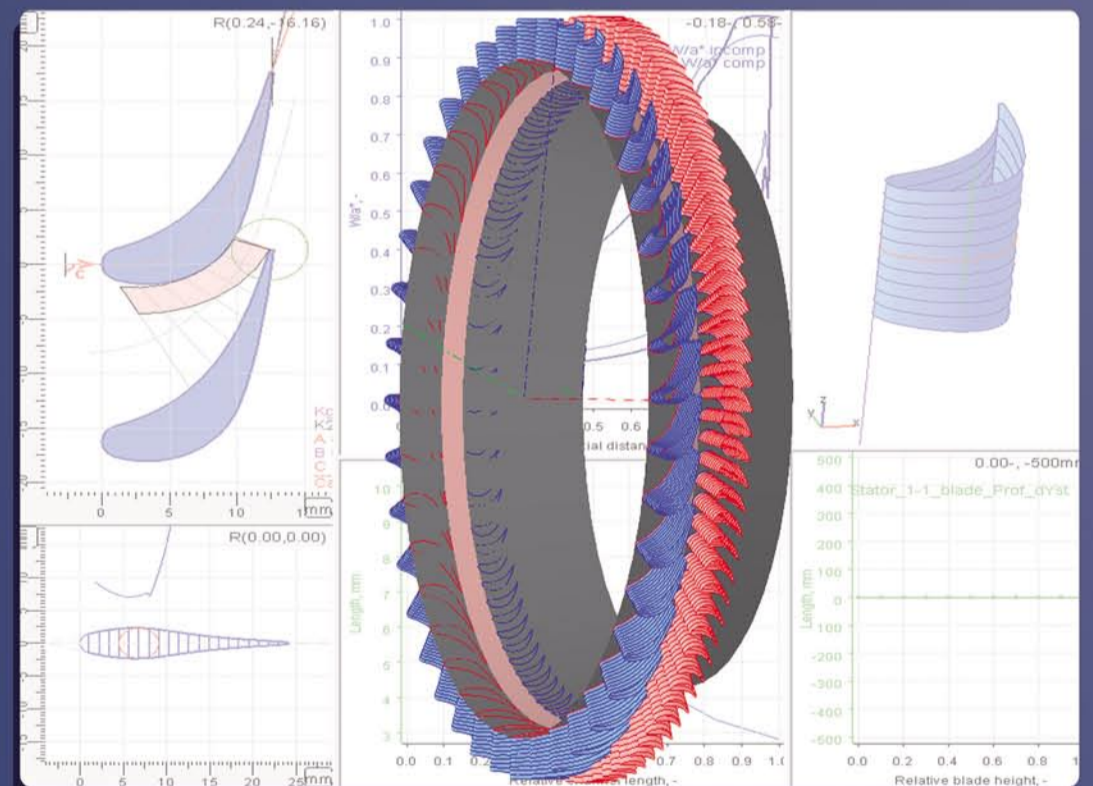

About Industrial Technology Research Institute of Taiwan:

Industrial Technology Research Institute (ITRI) is a nonprofit R&D organization engaging in applied research and technical services. Founded in 1973, ITRI has played a vital role in transforming Taiwan's economy from a labor-intensive industry to a high-tech industry. Numerous well-known, high-tech companies in Taiwan, such as leaders in the semiconductor industry TSMC and UMC, can trace their origins to ITRI.

About SoftInWay:

SoftInWay Inc. was started in 1999, and now is a global engineering company specializing in developing efficient turbomachinery by offering our flagship software, AxSTREAM for flow path design, analysis, and optimization as well as consulting services and educational courses. We now have 4 offices: Burlington, MA, USA (HQ); Kharkov, Ukraine; Bangalore, India; Zug, Switzerland.



## SOFTINWAY INC.

15 New England Executive Park • Burlington, MA 01803, USA • Tel: +1 781-685-4942 • www.SoftInWay.com