

Cellar Drainage

Pumping solutions to lift water , for example from a cellar or garage pit, to mains drains.

Prefabricated sumps are available in a variety of styles to suit many applications.

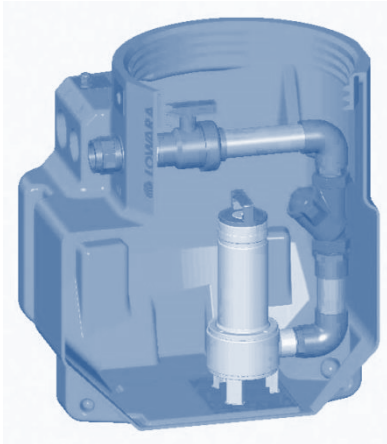

- Polyurethane sump
- Single or dual pump
- Single or three phase
- Option of remote control panel
- Above or below ground installation



MANUAL
Submersible pump.



AUTO – Swing Float
Submersible pump.



AUTO – Tube Float
Submersible pump.



- Polyurethane sump
- Single phase
- Auto operation without control panel



AUTO – Puddle Sucker
Submersible pump.



- GRP sump
- Single phase
- Auto operation without control panel
- Integrated grill and silt trap

Carter Pumps can also help with . . .

Installation and commissioning.

Electrical works. We are an NICEIC approved electrical contractor.

Ground works and civils.

Telemetry

