

HAYER & BOECKER



NIAGARA

F-CLASS PORTABLE PLANT



F-CLASS PORTABLE PLANT CASE STUDIES

PIDHERNEY'S

A One-Stop Shop

Pidherney's is one of Alberta's largest trucking and heavy construction companies. Started by Merv Pidherney in 1964, the company now employs 650 people and crushes 250,000 to 500,000 tons of aggregates annually. Pidherney's produces aggregates for roadbuilding projects, oilfield sites, ready mix plants and water and sewer civil works projects.

Pidherney's has an impressive fleet of equipment that includes more than 100 gravel and low-bed trucks, as well as a variety of excavators, scrapers, dozers, loaders, rock trucks, packers, crushers, screens, hydrovac trucks and more. To help keep up and expand its aggregates operations, they invested in a Haver & Boecker Niagara F-Class 1100 Portable Plant.

The F-Class Portable Plant is designed to maneuver easily between different locations and boasts a number of features and benefits, many of which were notable to the Pidherney's team. Pidherney's estimates that their new F-Class Portable Plant has helped them to increase production by 25%. The operation especially noticed the durability of the Ty-Max and Ty-Wire screen media, convenience of the Ty-Rail quick tensioning system, and the option for changing screen sections easily by lowering the machine to a horizontal position.



“ The F-Class Portable Plant exceeded expectations. I looked at other plants and they just didn't meet our needs. I wanted a trouble-free plant and I got it. You can tell the people that built it knew what they were doing. ”

– Merv Pidherney, Pidherney's owner

F-CLASS VIBRATING SCREEN

Niagara F-Class Portable Plants offer the ideal solution for challenging screening applications requiring consistent performance, load independence and minimal vibration transmission into the chassis.

WHY USE AN INCLINED MACHINE ON A PORTABLE PLANT?

A circular motion inclined vibrating screen uses gravity to help move material down the screen deck, reducing pegging as well as energy and horsepower requirements. There are differences in the rate of material travel between an inclined and horizontal machine. At 45 to 50 feet per minute (and at a specific tonnage) a horizontal screen will experience diminished capacity due to a greater bed depth. Alternatively, on a 20-degree incline and at 70 to 75 feet per minute travel rate, an inclined screen will deliver up to 25% more capacity than a linear-stroke horizontal machine.

FEATURES

- Double eccentric shaft assembly maintains constant g-force during start-up, shut-down, and extreme operating conditions including overloading and surging.
- Shear rubber mounting system provides smoother operation than traditional springs, reduces noise, and minimizes lateral movement, extending the life of your vibrating screen.
- Dynamically balanced design eliminates dynamic loads into the chassis to improve safety.
- Hydraulic system allows for set-up in 30 minutes, positioning the screen at an optimal angle of 20 degrees.
- The vibrating screen can be lowered in less than 5 minutes for easy screen media change-outs.
- Optional end-tension bottom deck available for easier maintenance, increased throughput and reduced pegging.
- Split-bucket mounting system reduces bearing replacement time by giving easy access to critical components.
- Tubular base frame is stronger than a traditional I-beam base frame to provide solid support for the robust machine.
- Motor support attached to the base frame eliminates additional structure.
- Options — such as a spray system, motor or dust enclosure — install easily on existing F-Class base frame.



F-CLASS SPECIFICATIONS

APPLICATIONS

- Scalping
- Dedusting
- Classifying (Wet or Dry)

INDUSTRIES

- Aggregates
- Mining
- Minerals



CLASS	WIDTH	LENGTH	DECKS	CUT RANGE	TOP SIZE	CAPACITY IN TPH	INCLINATION	BEARINGS	LUBRICATION	ACCELERATION
F	6'	12'	1 - 3	1/8" - 6"	16" minus	Up to 800	20°	4	Grease	3.8 - 4.2g
		16'								
		20'								
	8'	16'				Up to 1,200				
20'										

F-CLASS ACCESSORIES



TY-RAIL™

Every side-tensioned deck on an F-Class Portable Plant is engineered with Ty-Rail. The patented quick-tensioning system cuts screen change-out time in half, drastically reducing costly downtime, and improving productivity and profit, for a fast return on investment.

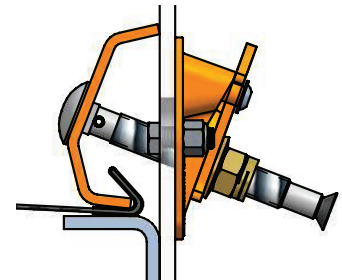

UPGRADE OPTIONS

- **POLYURETHANE LINERS**
Polyurethane feed box, side-plate, discharge lip and bar rail liners extend the wear life of your F-Class and screen media.
- **SPRAY SYSTEM**
Effectively wash or rinse dirty or contaminated materials during the screening process.
- **STATIONARY DUST SEAL**
Reduce dust emissions on vibrating screens.
- **BALL TRAYS**
Minimize blinding and pegging, and ensure sharper cuts; best for classification of fine and agglomerated material; available for wire cloth screen media applications only.
- **LUBRICATION SYSTEM**
Automated system supplies lubricant at required intervals to eliminate manual greasing.
- **FINES HOPPER**
Fits beneath the vibrating screen to collect under-size material.

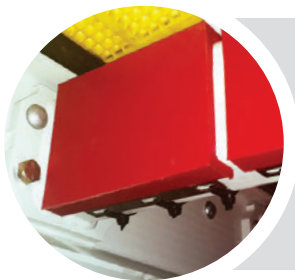

ZIP GUARD

Installing Zip Guard liners on the cross beams of your F-Class machine will reduce wear, extending the life of your machine and minimizing maintenance time.

F-CLASS VIBRATING SCREEN ANATOMY

REINFORCING PLATES

Reinforcing plates are located behind the bearing housing to sandwich the reinforcing plate, side-plate, shaft housing and flanged cross beam together without welding, adding strength.

FLANGED SHAFT HOUSING

The flanged shaft housing features Huck bolts on either side to maintain the factory seal between the shaft housing and side-plate. It also holds the shaft assembly in place during bearing changes for easier maintenance.

FLANGED CROSS BEAMS

Flanged cross beams increase the rigidity of the deck frame and allow the cross beams to be changed individually.

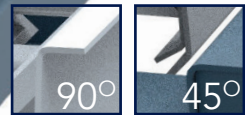
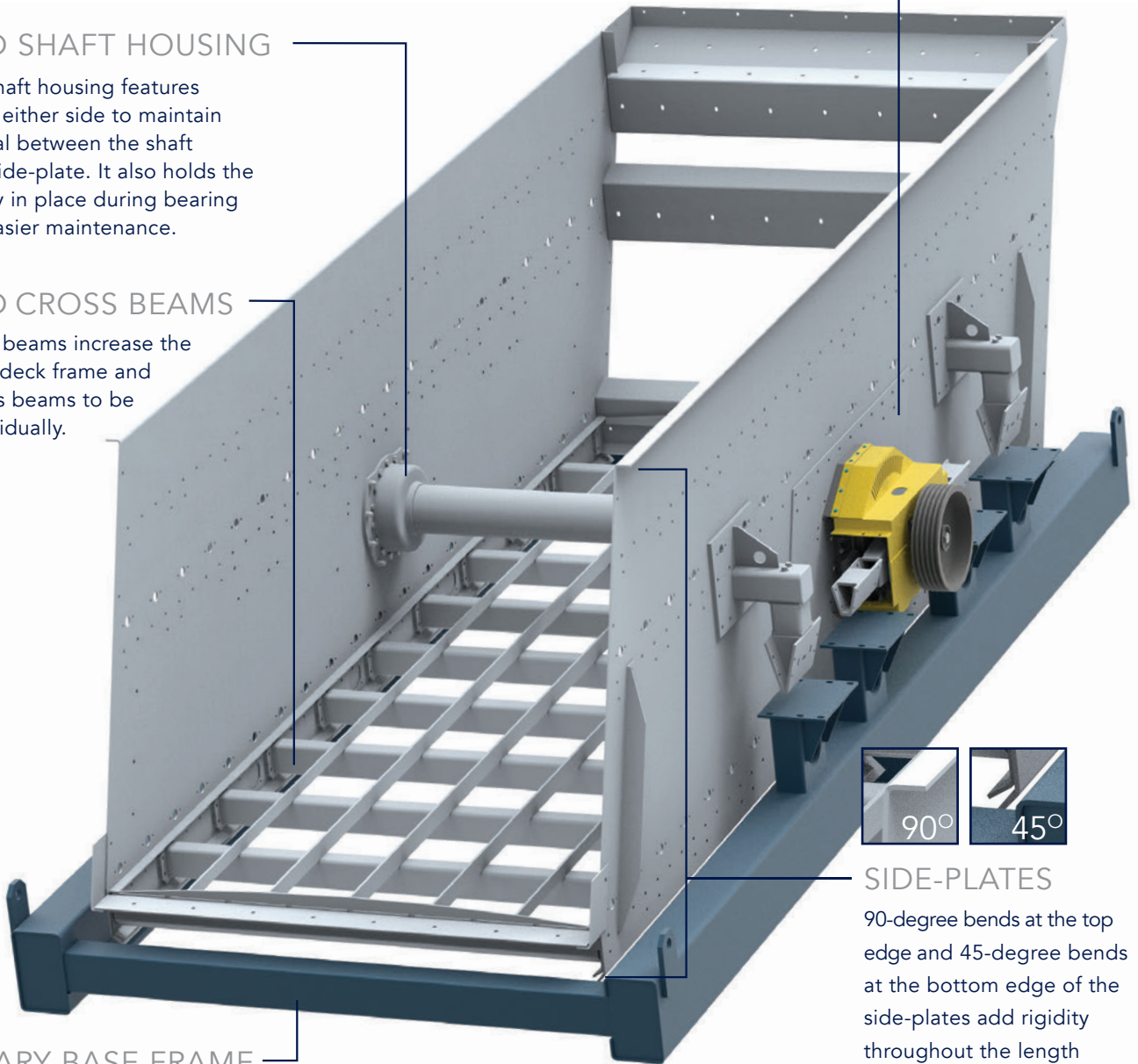

SIDE-PLATES

90-degree bends at the top edge and 45-degree bends at the bottom edge of the side-plates add rigidity throughout the length without welding.

STATIONARY BASE FRAME

Each F-Class comes with a stationary base frame to support the robust machine.

SHEAR RUBBER MOUNTING SYSTEM

Shear rubber mounting system provides smoother operation than traditional springs, reduces noise, and minimizes lateral movement, extending the life of your vibrating screen.

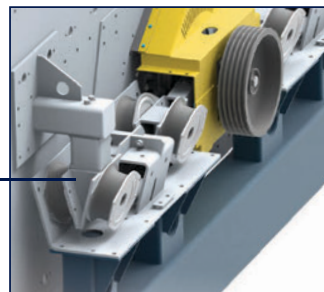

DOUBLE ECCENTRIC SHAFT

Supported by spherical roller bearings, the double eccentric shaft creates a constant positive stroke that handles material surging without losing momentum. As the shaft turns, the screen body is forced to follow the shaft movement. While it travels upward, the counterbalance weights move in the opposite direction and create an equal force to that generated by the body. The forces cancel each other, creating a dynamically balanced system that transmits minimal to no vibration into the chassis.

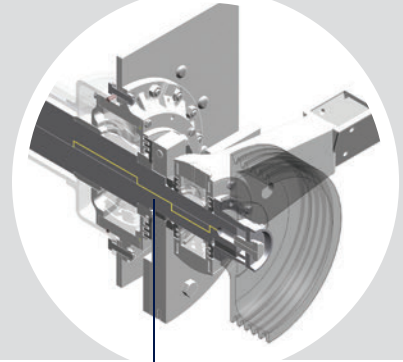

POLYURETHANE LINERS

We recommend polyurethane feed box, discharge lip, side-plate and bar rail liners to extend the wear life of your F-Class and screen media.

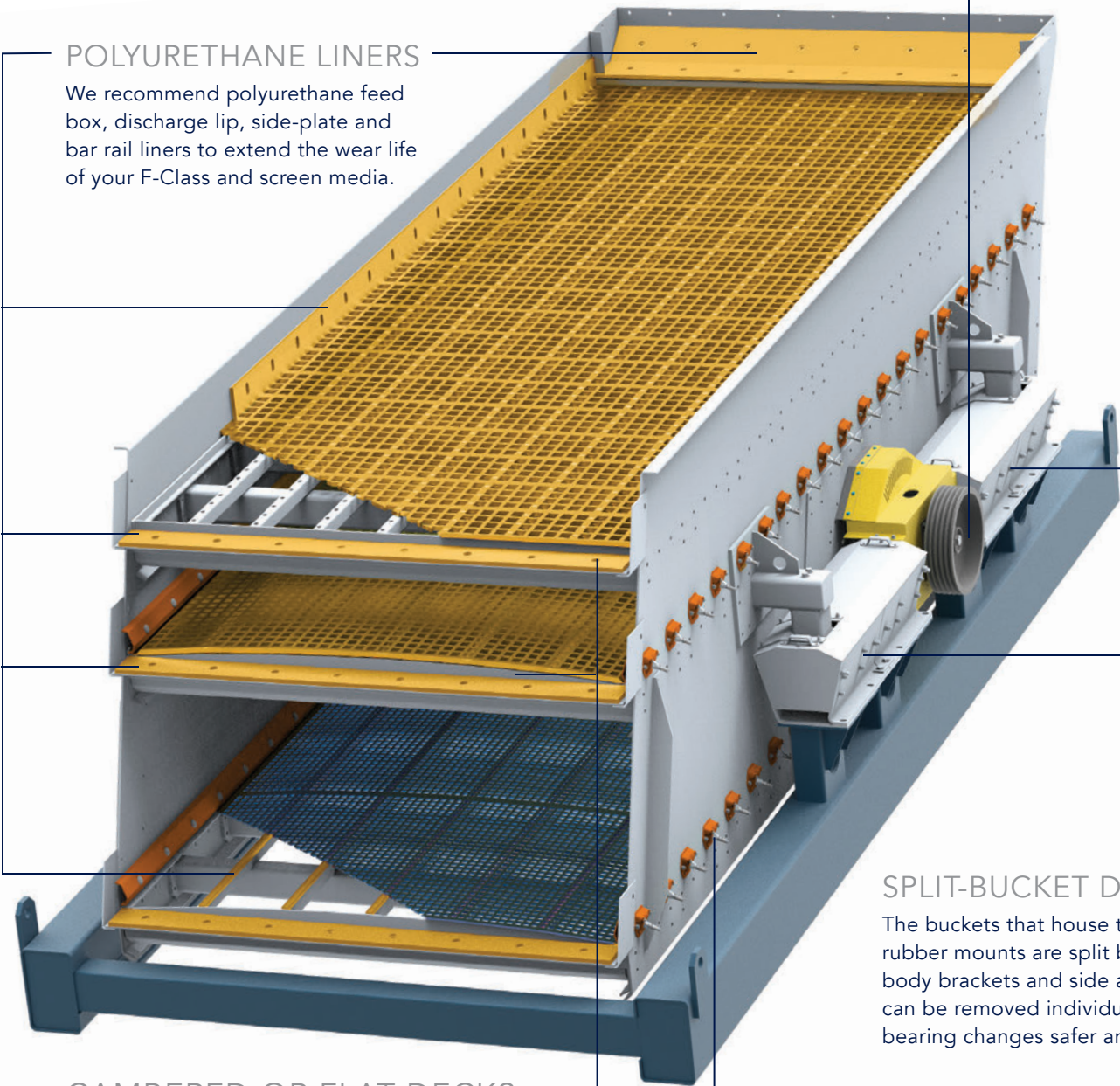

CAMBERED OR FLAT DECKS

The F-Class can be customized with cambered or flat decks to accommodate virtually any combination of tensioned or modular screen media.

SPLIT-BUCKET DESIGN

The buckets that house the shear rubber mounts are split between the body brackets and side arms. They can be removed individually to make bearing changes safer and faster.

TY-RAIL™

All cambered decks come complete with the patented Ty-Rail quick-tensioning system.

F-CLASS PORTABLE PLANT ANATOMY

FAST SETUP

On-board hydraulic power unit allows for set-up in under 30 minutes and vibrating screen can be lowered in less than 5 minutes for easy screen media change-outs.

OPTIONAL MAGNETIC SEPARATOR

Prevents tramp iron from contaminating the material.

OVERSIZE CHUTE

The oversize chute's AR liners are bolted-on for easy replacement.

FEED CONVEYOR

Hydraulically adjustable for precise material placement.

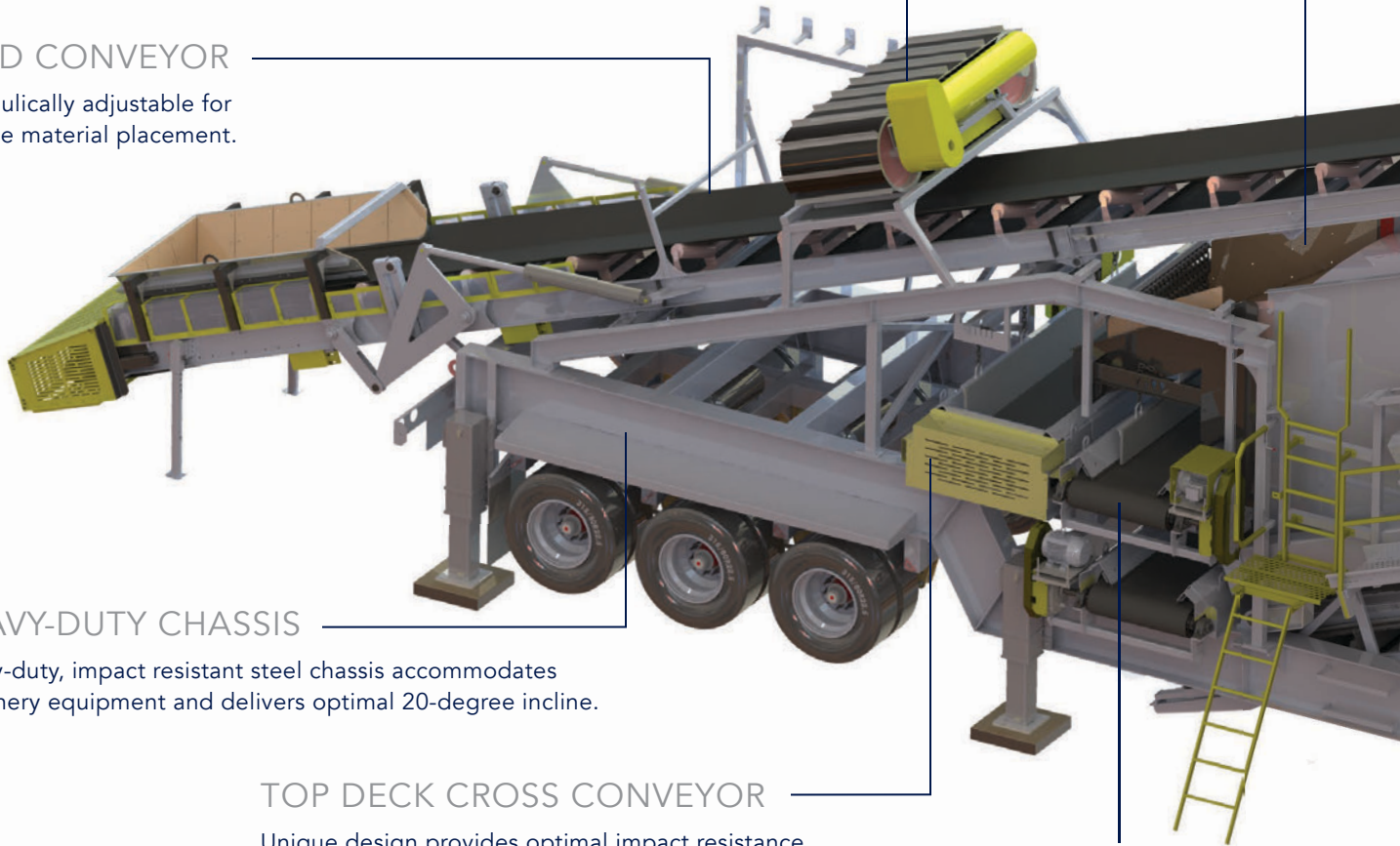

HEAVY-DUTY CHASSIS

Heavy-duty, impact resistant steel chassis accommodates periphery equipment and delivers optimal 20-degree incline.

TOP DECK CROSS CONVEYOR

Unique design provides optimal impact resistance.

MIDDLE AND BOTTOM DECK CROSS CONVEYORS

Removable top sections simplify skirting and belt replacements.



REMOVABLE SUSPENSION

Bolted-on suspension can easily be removed as a complete cartridge to eliminate risk of damage during operation.

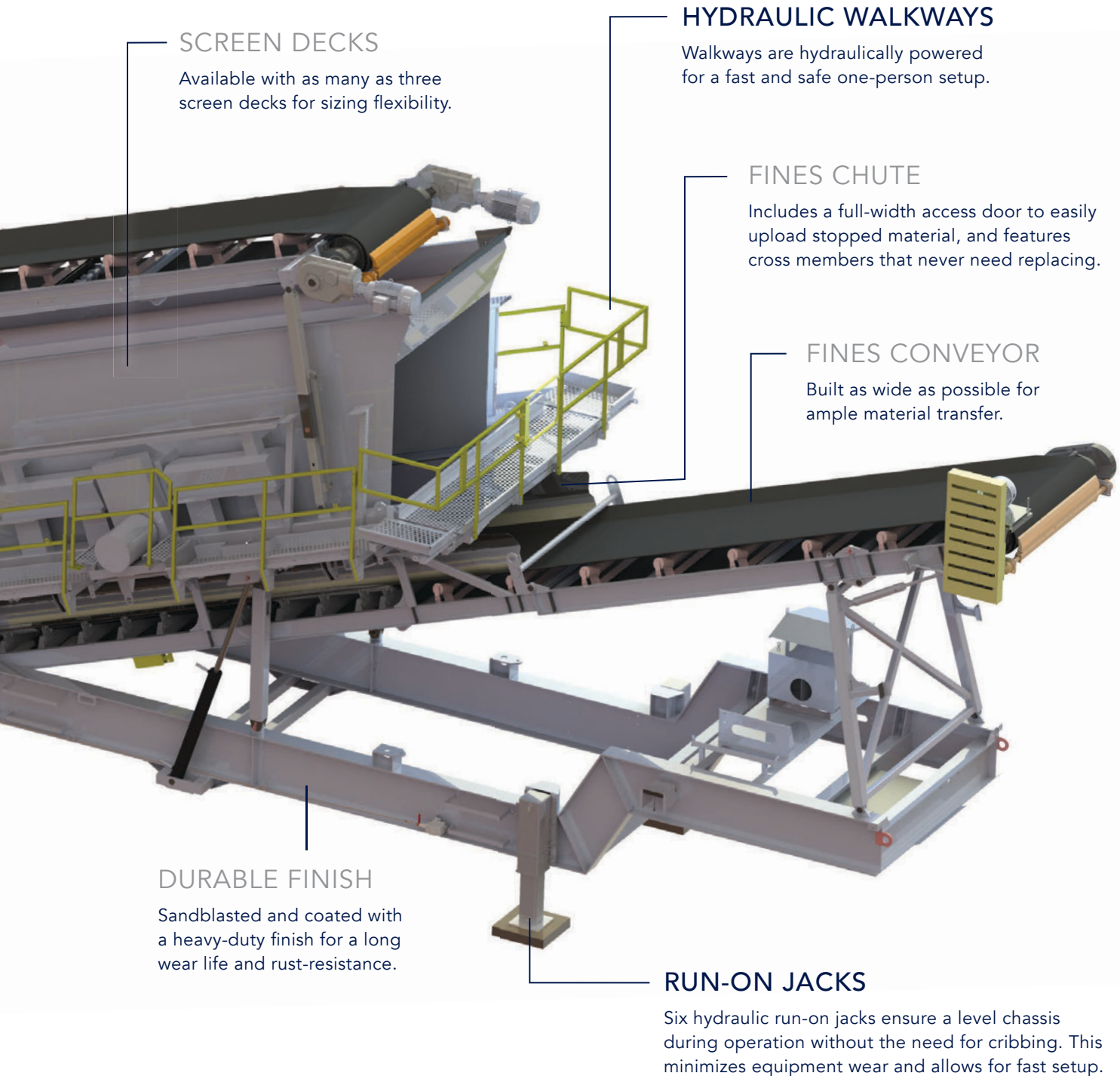

SCREEN DECKS

Available with as many as three screen decks for sizing flexibility.

HYDRAULIC WALKWAYS

Walkways are hydraulically powered for a fast and safe one-person setup.

FINES CHUTE

Includes a full-width access door to easily upload stopped material, and features cross members that never need replacing.

FINES CONVEYOR

Built as wide as possible for ample material transfer.

DURABLE FINISH

Sandblasted and coated with a heavy-duty finish for a long wear life and rust-resistance.

RUN-ON JACKS

Six hydraulic run-on jacks ensure a level chassis during operation without the need for cribbing. This minimizes equipment wear and allows for fast setup.

Portable Plants can be customized for other Niagara processing equipment.

F-CLASS SCREEN MEDIA



NIAFLOW PLANT SIMULATION SOFTWARE

NIAflow is used to design new mineral processing plants, or optimize existing plants, to predict production based on input tonnage, material characteristics and equipment setup.

SCREEN MEDIA

The F-Class Portable Plant can be engineered with a flat deck for modular screen media panels, including pin & sleeve, snap-in, groove or bolt-down fastening systems; a cambered deck for side-tensioned screen media with a single or double crown; or end-tensioned screen media. Proper screen media selection virtually eliminates blinding and pegging.

	MODULAR FOR FLAT-DECK	SIDE-TENSIONED FOR CAMBERED DECK	END-TENSIONED
POLYURETHANE	•	•	
HYBRID	•	•	
PERFORATED PLATE	•	•	
RUBBER	•	•	
WOVEN WIRE	•	•	•
SELF-CLEANING	•	•	•

Blending screen media on a single deck helps increase production and extend periods between screen change-outs. Here we've blended two panels of Ty-Max polyurethane on the feed end, with Ty-Wire hybrid screen media on the remaining sections to maximize wear life and open area.

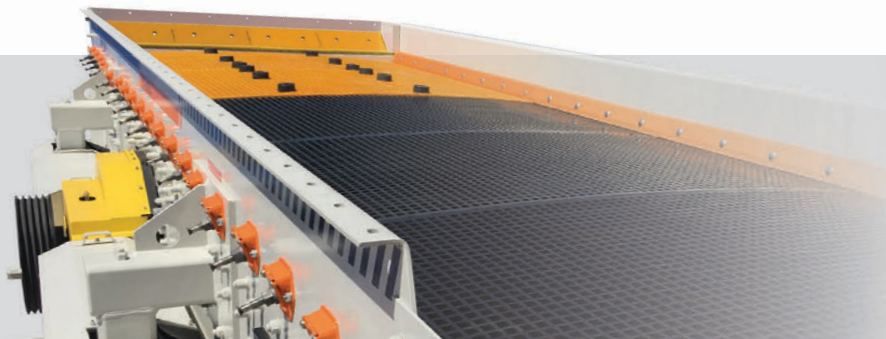

PULSE VIBRATION ANALYSIS SERVICE

Enhance screening operations with Pulse, Haver & Boecker Niagara's innovation in vibration analysis technology. Pulse is designed for analyzing the health of all vibrating screen brands. It detects irregularities that could translate into diminished performance, decreased efficiency, increased operating costs and imminent breakdowns. We use Pulse to understand an operation's screening challenges, then work with our customers to optimize the screening operation.

- Detailed reports contain OEM recommendations for maximizing screening efficiency and minimizing unscheduled downtime.
- Onsite training provides maintenance departments the skill and confidence necessary to maintain a productive operation.



“ Customers are always looking for ways to maximize production and minimize downtime. To instill confidence in our equipment's performance with our customers, we offer ongoing support and programs, like Pulse Vibration Analysis and our Uptime 3-year warranty. ”

– Karen Thompson, Haver & Boecker Niagara



F-CLASS PORTABLE PLANT CASE STUDIES

INTER-CITÉ CONSTRUCTION LTÉE

“ We didn't have an efficient and effective way to process all material sizes without contaminating our smallest aggregates, which made them unsellable. With the F-Class Portable Plant we are able to stay at our ideal production rates while significantly increasing output of clean, sellable material as small as 6.4 millimeters. And the Ty-Rail system is a huge bonus that has boosted our profits even more thanks to impressively fast screen change-outs. ”

– Stéphane Julien, Inter-Cité Construction Ltée



CANADA

East: +1 800-325-5993
West: +1 800-661-0362
info@haverniagara.ca
www.havercanada.com

BRAZIL

Equipment: +55 (19) 3879-9100
Screen Media: +55 (31) 3661-1371
Service: +55 (31) 3661-3508
info@haverbrasil.com.br
www.haverbrasil.com.br

GERMANY

+49 (0) 251 9793-0
info@haverniagara.com
www.haverniagara.com

HAVER & BOECKER



NIAGARA