

# Performance Evaluation

## Highlights

- Pinpoint issues with state-of-the-art diagnostic tools for modern networks
- Evaluate virtually any DSL system with a hardware-agnostic software solution
- Receive detailed graphical analysis and reports in real time
- Provide Web-based remote access for technicians
- See immediate savings — in excess of \$100 million for large networks

## DSL Diagnostic Tools Designed for the Modern Network

Today there are more than 300 million DSL subscribers worldwide—far more than fiber, fixed wireless, and cable combined—and that number continues to grow. In this era of hyper-connectivity, DSL technology has become much more than simply a way to access the Internet. Subscribers expect a high-performance, highly reliable network, and for service providers to deliver they need advanced troubleshooting capabilities that help ensure a minimal mean time to repair (MTTR) and give them a strong competitive edge.

Traditional testing approaches have typically evolved from hardware-based, vendor-centric plain old telephone service diagnostics tools. Since these were not designed with DSL testing in mind, many service providers find that they lack the required functionality and ultimately prove inadequate (see Figure 1).

The award-winning ASSIA® DSL Express® Performance Evaluation module delivers state-of-the-art DSL diagnostic tools designed to support a modern network. This hardware-agnostic solution is entirely software based, automatically collecting operational and performance data and converting them into graphical reports that accurately detail:

- Discovered faults
- Fault location when relevant

- DSL performance impact
- Recommended corrective action
- Likely improvements once the fault is remedied

## Reduce Your DSL Test and Network Maintenance Expenses

The ASSIA DSL Express solution provides a user-friendly interface with easy, Web-based remote access to the rich set of diagnostic tools for all technicians. This helps eliminate the need to invest in expensive hardware probes or test sets, multiple training sessions, and prohibitive hardware maintenance contracts. As a result, service providers have reported savings in excess of \$100 million, depending on the size of the network and maintenance crews.

Since ASSIA DSL Express Performance Evaluation is non-disruptive, diagnostics can be performed at any time without having to interrupt the customer's service.

Furthermore, the tool is available to your entire technical staff for the same cost; you do not have to perform challenging tradeoffs between customer satisfaction and network diagnostics expenses.

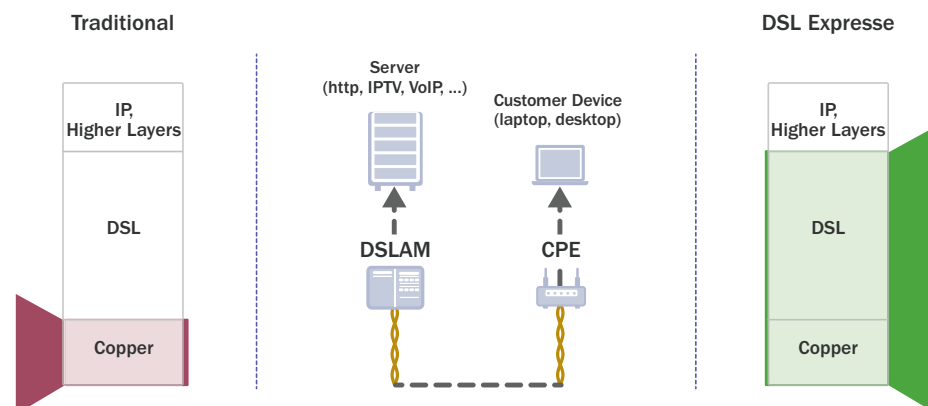

FIGURE 1. Traditional test approach coverage versus DSL-focused approach (DELT)

Non-disruptive diagnostics mean no downtime in service to the customer.

## Increase Dispatch Efficiency and Reduce Costs

ASSIA DSL Expresse locates faults and recommends corrective action so technicians can resolve any issues quickly and efficiently. This can help reduce the number of repeat dispatches by up to 50 percent. Leveraging a dispatch recommendation from the ASSIA DSL Expresse Performance Evaluation module helps service providers improve dispatch efficiency. For instance, one service provider reported efficiency increases of 39 percent when considering the percentage of DSL issues fixed after dispatch. This reduced the useful dispatch cost by as much as 30 percent in this case (see Figure 2).

The historical information stored in the ASSIA DSL Expresse database includes identifying varying trends in time and weather, allowing for highly effective troubleshooting, even when faults appear to be random in nature.

In addition, the proactive dispatch report also included in the Performance Evaluation module lets dispatchers optimize the routes and timing of repair teams by proactively addressing issues with the copper plant near a prior intervention.

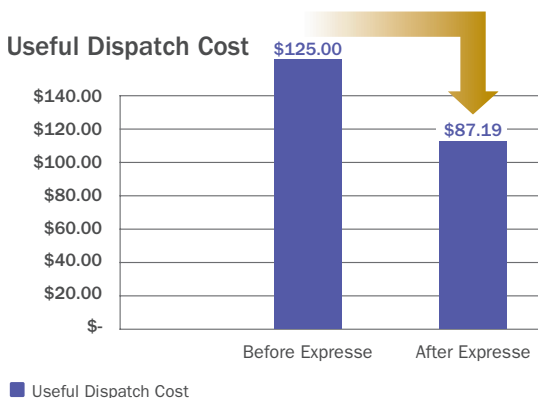

**FIGURE 2.** Useful Dispatch Cost Evolution for an ASSIA customer before and after ASSIA DSL Expresse deployment. (Useful dispatch is defined as any dispatch not classified as No Trouble Found.)

## State of the Art DSL Testing for Modern Networks

With higher DSL frequencies, such as VDSL2 and the soon-to-come G.Vector, detection and analysis of minute interferences or impairments has become more critical than ever before. Previous technologies, such as ADSL2+, were more fault tolerant, so less sophisticated diagnostic tools often could suffice. Today, the need for an always-on, pure software, ubiquitous and highly accurate diagnostics solution has never been greater. Modern broadband networks use DSLAMS that are increasingly remote and installed in locations with limited space to add hardware probes. At the same time, there also

has been an increase in the number and type of mission-critical real-time applications carried over DSL, such as IPTV and VoIP.

## Real-time Analysis Helps Ensure World-class Customer Satisfaction

ASSIA DSL Expresse includes an additional licensing option known as Real-Time Analysis for the Performance Evaluation module.

This capability can easily be accessed by the field technician while on dispatch, and confirms in real time that the problem has actually been fixed and that DSL performance is restored or enhanced. The result is an improvement in technician performance in the field and a reduction in the number of repeat calls and dispatches.

This powerful, real-time Performance Evaluation module may be integrated through ASSIA professional services into the service provider's Interactive Voice Response (IVR) system, enabling intelligent triage to level-2 DSL technicians when an actual physical layer fault is detected by ASSIA DSL Expresse. This helps reduce the unnecessary level-1 manual investigation and increases customer satisfaction.

Real-time Performance Evaluation allows field technicians and contact-center agents to inspect a line closely by requesting additional data collection with a configurable schedule. If supported by the corresponding DSLAM, they can further examine the traffic volumes for a specified broadband connection in real-time.

The real-time diagnostics in the ASSIA DSL Expresse Performance Evaluation module provide expert DSL technicians with access to highly advanced DSL performance data (see Figure 3), including per-tone data for all types of access supported by ASSIA DSL Expresse. This lets technicians perform their own analysis and fine tune the diagnostics results from ASSIA DSL Expresse.

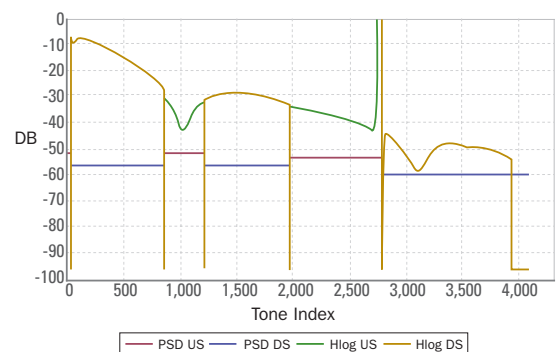

**FIGURE 3.** PSD and Hlog for both DS and US for a 550-meter VDSL line with a bridge tap

## Contact ASSIA today

+1.650.654.3400  
or email  
sales@assia-inc.com



333 Twin Dolphin Drive  
Redwood City, CA 94065  
Tel: +1-650-654-3400  
Fax: +1-650-654-3404  
www.assia-inc.com

© 2011 ASSIA, Incorporated.  
All rights reserved.

ASSIA, the ASSIA logo, and DSL Expresse are registered trademarks of ASSIA, Incorporated. All other product names, company names, logos, and trademarks are used herein for identification purposes only and are the property of their respective companies.

Rev 050511 P/N MCE2-0111-01-00