



The MSB Rack

Assembly Guide

Check our website for the most recent user guides, firmware, and drivers:
www.msbtechnology.com

Technical support email is:
techsupport@msbtech.com

10.28.2019

Step 1

- Place the first cross brace over the 4 four feet provided in the starter box.

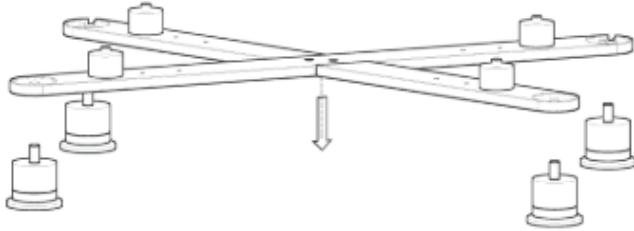

Step 4

- Place the first platform on top of the isolators. Take caution to be sure each of the isolators pins are aligned and in each of the holes in the bottom of the platform before resting any equipment on the rack.

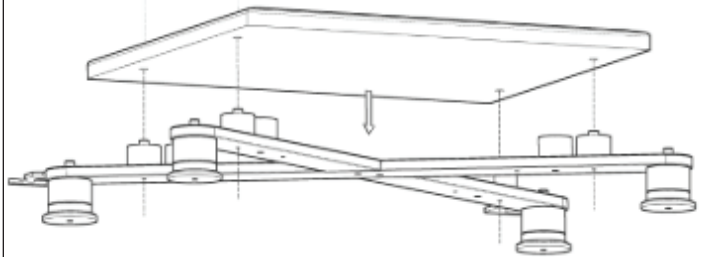

Step 2

- Screw in any extra required isolators.

- 1 set (4pcs) are required for every 33lbs (15kgs) of equipment weight. Up to a maximum of 132lbs (60kgs).

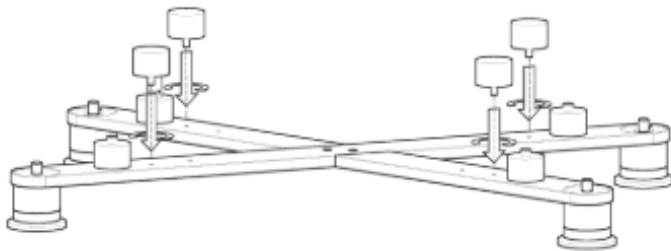

Step 5 (Starter pack only)

- If you have only purchased the starter pack and are not adding anymore shelves to this rack system, screw in the top caps.

- If you are adding additional shelves, skip this step and continue on to "Step 6"

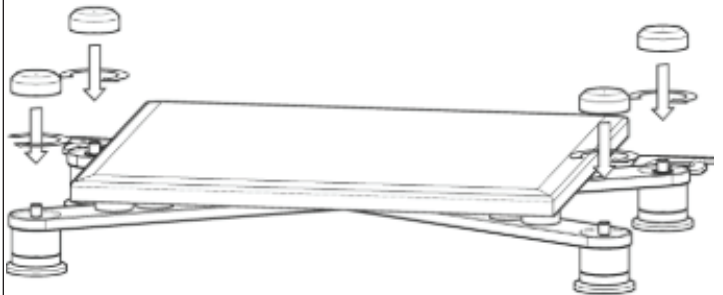

Step 3 (optional)

- Insert the Cable management hooks with the opening portion facing away from the center of the rack.

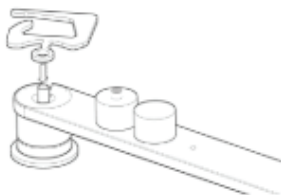

Left

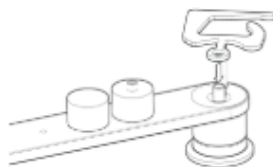

Right

Step 6

- Screw in the uprights provided in the extension kit.

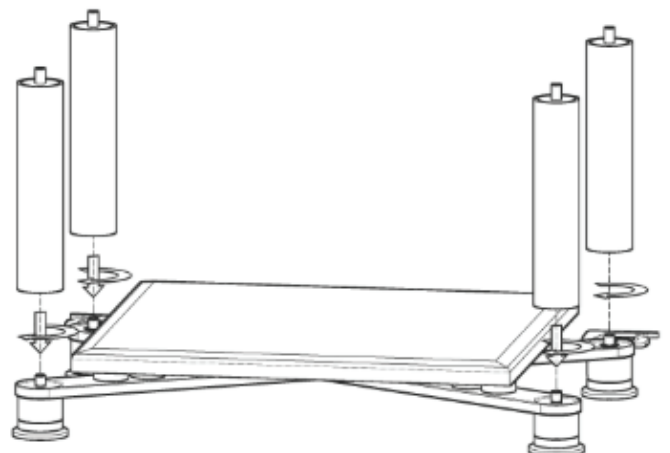

Step 7

- Place the next cross brace over the 4 four extensions provided in the box.

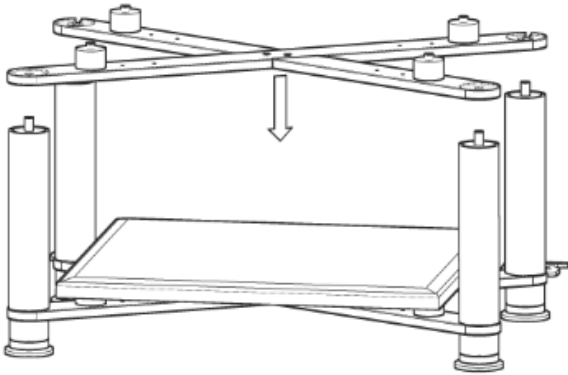

Step 10

- Place the first platform on top of the isolators. Take caution to be sure each of the isolators pins are aligned and in each of the holes in the bottom of the platform before resting any equipment on the rack.

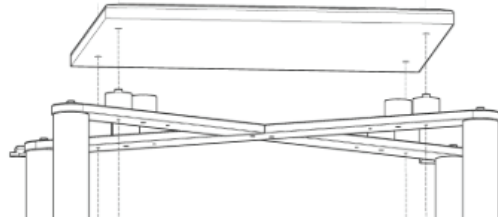

Step 8

- Screw in any extra required isolators.

- 1 set (4pcs) are required for every 33lbs (15kgs) of equipment weight. Up to a maximum of 132lbs (60kgs).

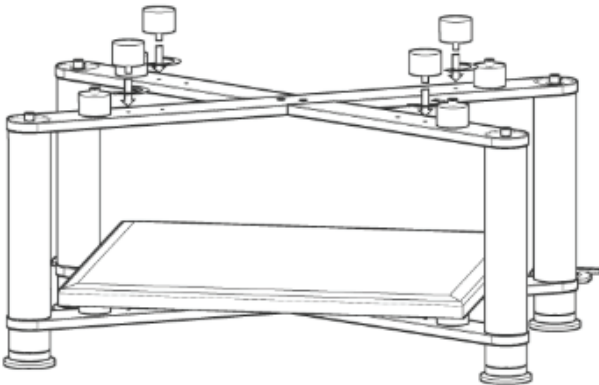

Step 5

- Screw in the top Caps.

- If you are adding additional shelves, Skip this step and start again at "Step 6"

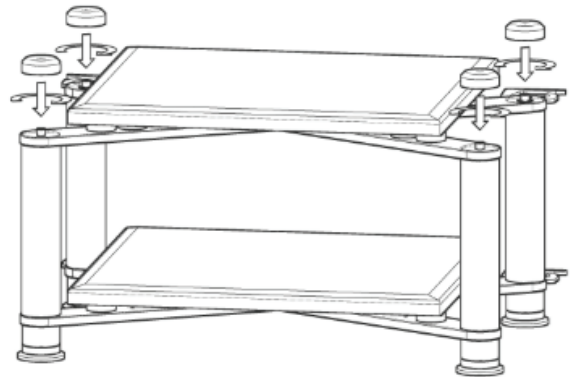

Step 9 (optional)

- Insert the Cable management hooks with the opening portion facing away from the center of the rack.

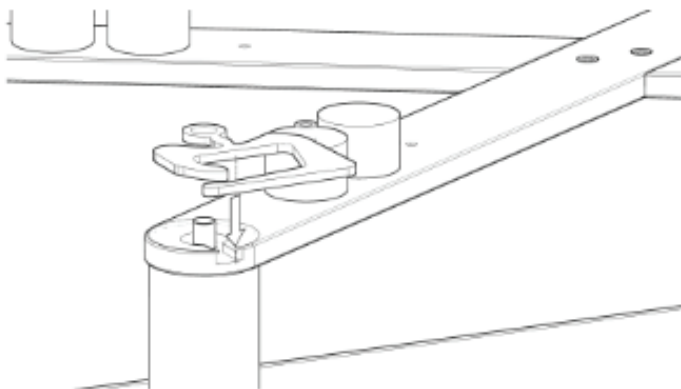

COMPLETE

