

2019 CATALOG

MRI QA

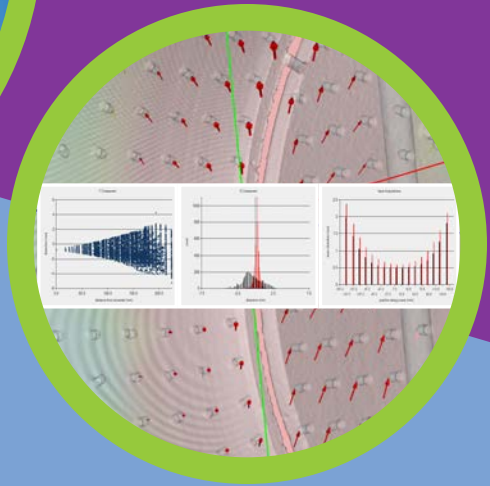

IGRT QA

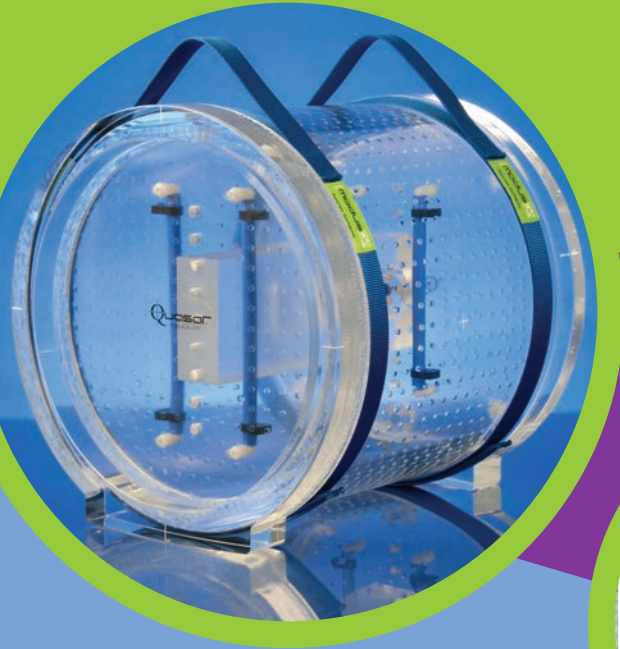
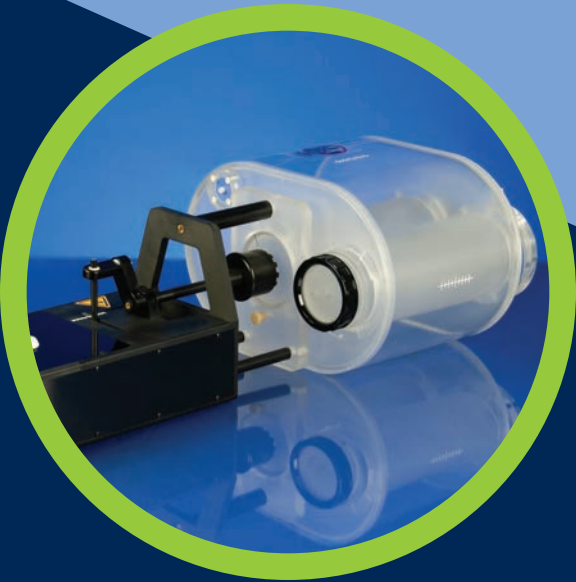

MOTION QA



[modusQA

Accuracy. Confidence.™



Quality Assurance System
for Advanced Radiotherapy

Founded in 2000, Modus Medical Devices Inc. develops and manufactures cost-effective and innovative quality assurance tools for advanced radiotherapy and medical imaging. Today, there are over 5,200 QUASAR™ phantoms being used in more than 3,400 leading treatment centres worldwide.



Advances in radiotherapy and medical imaging create the need for more sophisticated QA technology and solutions. Medical physicists are looking for ways to implement comprehensive test protocols and to reduce QA testing time, so they can get online faster and with more confidence.

Modus QA responds to this need by providing a wide range of QA phantoms and software for daily testing, commissioning new equipment and new techniques, and supporting the dosimetric and nondosimetric testing of upgrades, repairs and software fixes. Modus QA is proud to have been first to market in a number of significant areas, including: MRI-guided radiotherapy, daily on-board imaging, cone beam optical CT scanning for 3D dosimetry and nondosimetric QA. Modus QA also developed the first commercial programmable respiratory motion phantom and platform.

Modus QA has grown steadily based on a strong foundation of science, research, development and collaboration with medical physicists around the world. Today, Modus QA employees remain committed to assisting medical physicists in fulfilling their responsibilities more efficiently and accurately, which ultimately results in improved patient care.

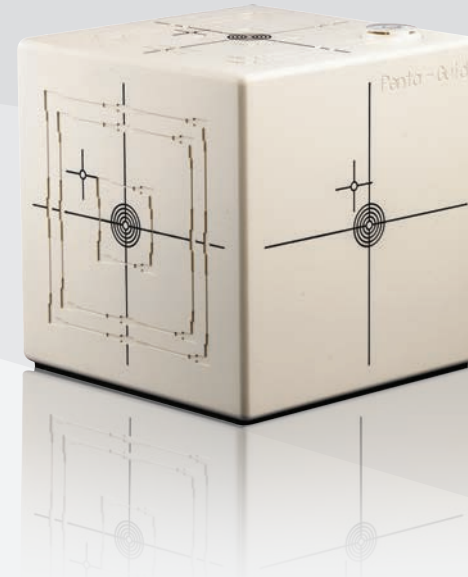

PROVIDING CONFIDENCE

From QA phantoms and software for MRI, IGRT, Motion and IMRT to 3D dosimetry and optical CT scanners, Modus QA products help medical physicists achieve confidence that tests are accurate and repeatable, ensuring that every patient is getting the best possible treatment.

DELIVERING ACCURACY

Driven by scientific roots and continued strong ties to the scientific community, Modus QA strives to remain at the forefront of the complex and ever-evolving advanced radiation therapy field.



ENSURING QUALITY

As a manufacturer, Modus QA ensures its products are built to the highest standards in accordance with stringent principles of process control and continuous improvement.

This commitment to quality is further reflected in the company's strong after-sales customer service and technical support.

**Committed to helping medical
physicists around the world
achieve accuracy... confidence**

TABLE OF CONTENTS

QUASAR™ MRID^{3D} Geometric Distortion Analysis System.....	4
QUASAR™ MRI^{4D} Motion Phantom.....	6
QUASAR™ GRID^{3D} Image Distortion Analysis System	8
QUASAR™ ISOCENTER CUBE IGRT Phantom.....	9
QUASAR™ PENTA-GUIDE IGRT Phantom.....	10
QUASAR™ WAND IGRT Phantom.....	12
QUASAR™ CPRESP Motion Phantom.....	13
QUASAR™ PLATFORM Motion Phantom.....	14
QUASAR™ MP BODY IMRT Phantom	15
QUASAR™ PRESP Motion Phantom.....	16



US Pat. 9,857,443
10,082,550

The Best Way to QUANTIFY MRI GEOMETRIC DISTORTION IN 3D!



WORKFLOW EFFICIENCY

Quickly setup, scan and quantify geometric distortion measurements in as little as 10 minutes with a lighter, larger and faster analysis system.



GEOMETRIC ACCURACY

Large FOV phantom design follows recommendations from NEMA/ MITA MS-12 and IEC 62464-1 for highest accuracy even when distortion is high and vendor correction is off.



DIMENSIONAL STABILITY

Integrated expansion tubes (patent pending) compensate for changes in liquid volume, caused by changes in temperature and pressure, ensuring the phantom is dimensionally stable.



HARMONIC ANALYSIS

Adapts analytical techniques that are routinely used in MRI B0 shimming and gradient coil design.



VISUALIZATION TOOLS

Dynamic statistical graphics allow users to explore, visualize, summarize and export quantitative data.



REAL-TIME ANALYSIS

Interactive ROI selector enables users to update statistics for user-defined sub regions (e.g. spheres, cylinders and cuboids).

QUASAR™ MRID^{3D} is a lighter, larger and more efficient measurement technique that leverages harmonic analysis to quantify MRI geometric distortion in 3D.



Harmonic analysis is a well-established mathematical tool used to solve electromagnetism problems with well-defined boundary conditions including MRI gradient coil design and B0 shimming. The QUASAR MRID^{3D} Geometric Distortion Analysis System extends this approach by measuring distortions on the closed surface of a boundary phantom and then uses harmonic analysis to calculate the distortions inside. This permits the use of a lighter, larger, hollow boundary phantom.

At 21 kg, the 39.4 cm diameter by 39.1 cm long phantom is half the weight of a water-filled grid phantom of the same volume. It includes recessed handles for safe carrying plus integrated 3 point contact feet and engraved landmarks for convenient OSHA compliant (under 50 lbs.) one person set-up. Fiducials in the acrylic phantom contain susceptibility matched mineral oil for fast high contrast 3D T1W scanning. Mineral oil is non-reactive and allows plastics to remain dimensionally stable over time unlike water which causes plastics to swell. The maintenance free phantom never has to be drained or refilled. The low dielectric constant mineral oil permits dielectric-resonance-free use at high field strengths.

The system includes robust, mature, client-based image analysis software. The built-in DICOM receiver ensures efficient file transfer. There is no waiting for files to upload to the cloud thus avoiding associated IT issues. Control point detection and harmonic analysis are fully automated; from phantom setup to

results in as little as 10 minutes. Software features include the ability to separate distortions caused by main magnetic field inhomogeneities from those caused by gradient non-linearities. A region of interest selector allows users to focus their analysis on targeted regions for more demanding applications such as SRS. A rich set of data presentation tools allows trending and comparison amongst a diverse selection of phantom scans. Users can export customizable automated reports including full DVf spreadsheets.

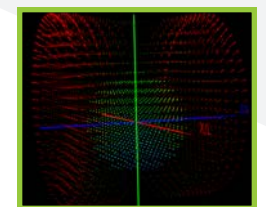
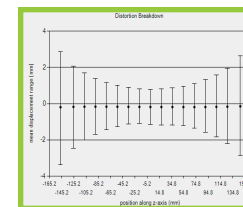
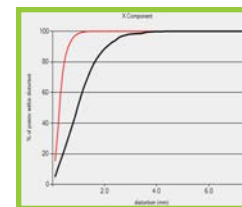
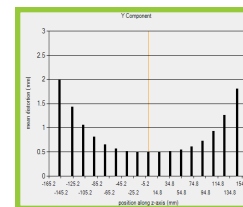

The modern approach of QUASAR MRID^{3D} is a better, faster and lighter alternative for routine distortion assessment. GRID phantoms are either too small or too heavy. A properly designed distortion analysis system quantifies machine induced distortions. GRID phantoms do not accurately simulate patient susceptibility distortion. The QUASAR MRID^{3D} phantom is carefully designed to minimize perturbations to the magnetic fields you are trying to measure, thus ensuring that the phantom does not bias the measurement.



US Pat. 10,090,781

MR Safe 4D Motion QA for Adaptive MRgRT and MR Simulation applications



The programmable QUASAR™ MRI^{4D} Motion Phantom is designed to move liquid or gel filled cylindrical inserts within a contrast media filled body shaped oval at varying speeds and amplitudes.

The phantom is capable of moving inserts in the S/I direction as well as producing a more complex 3D motion profile by twisting the insert during translation. Interchangeable inserts are available for imaging, planning, targeting and delivery QA. Included with the phantom is the QUASAR™ Respiratory Motion QA Software application which allows you to quickly create user-defined waveforms or import custom waveforms produced using tab delimited spreadsheet files.

Conveniently import, edit and save patient-specific waveforms from a number of third party respiratory gating formats including: .VXP, .CSV, .TXT, .DCM, .LOG, .DAF, IMA. Editing capabilities include a wide range of functions: adjusting the amplitude, stretching or compressing the timeline, and filtering high frequency noise, low frequency drift and cardiac signals.



100% MR SAFE

Efficient piezoelectric motor assembly with no ferrous content allows for quick, easy and precise operation in Magnetic Resonance Imaging suites with no projectile hazard up to 7T.



OPTIMIZED SHIELDING

The patent protected piezoelectric motor design employs highly effective proprietary RF noise suppression techniques with optimized shielding to preserve MR image quality with no motor induced image artefacts.



COMPACT DESIGN

Quick and easy to set-up, position and operate in the head or feet-first direction for fast and efficient commissioning and routine 4D-MRI QA.



BODY OVAL PHANTOM

Contains offset and central cylindrical thru holes, which provide low or medium body mass attenuation, for interchangeable stationary and motion inserts.



INTERCHANGEABLE INSERTS

Includes two configurable imaging inserts with spherical target, stem and base lids. Optional ion chamber, film and dosimetry inserts are also available.



WORKFLOW EFFICIENCY

Integrated phantom design along with easy-to-use motion software saves time and increases operational efficiency by reducing or eliminating the need for complex or tedious assembly before operation.

Compatible with low and high field strength MRI scanners

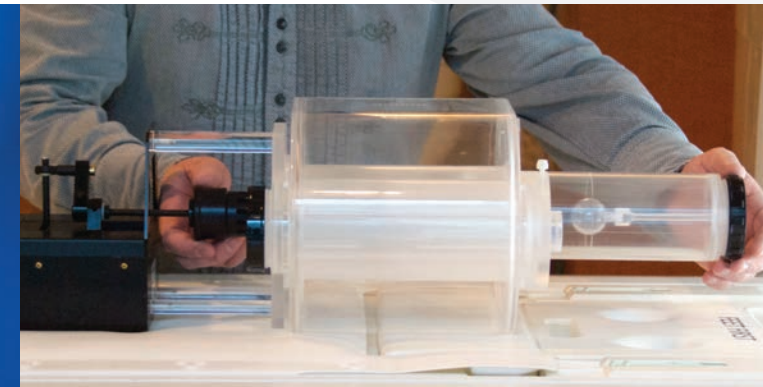
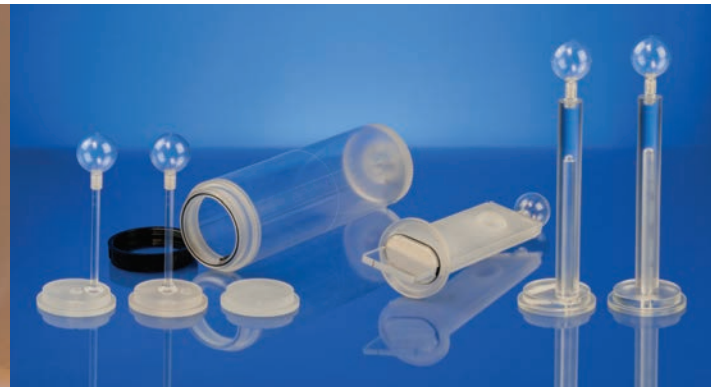



Quantify Geometric Distortion in 3D for Gamma Knife®

KEY FEATURES

- ▶ Verify geometric accuracy of different MR images for SRS
- ▶ Designed specifically for the Leksell Gamma Knife®, including PERFEXION™
- ▶ Automated image analysis provides full 3D distortion map with submillimeter accuracy

MR-GUIDED STEREOTACTIC RADIOSURGERY QA

The QUASAR™ GRID^{3D} Image Distortion Analysis System evaluates image distortion in 3D MR images for stereotactic radiosurgery.

The system is comprised of a phantom and analysis software which work together to produce a 3D map of spatial distortion with submillimeter accuracy throughout a volume of interest. The GRID^{3D} system ensures that MR imaging can support the outstanding geometric precision and dosimetric accuracy of the Leksell Gamma Knife®, including PERFEXION™.

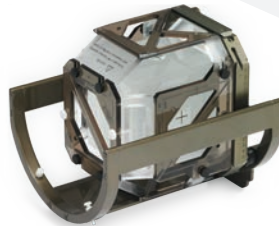

ANALYSIS SOFTWARE

DICOM images of the phantom are imported into the software. These images can be axial or coronal MR, as well as CT.

The software automatically finds the Leksell fiducials and a proprietary algorithm accurately determines the x, y, and z deviations of each vertex in the image.

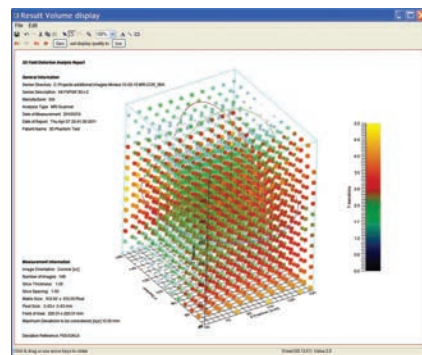

Users can then interrogate and, if necessary, edit the results vertex by vertex, as well as plane by plane throughout the region of interest.

The results are displayed in a tabular form and in a 3D display. The software saves the analysis results and generates a report in Excel. The software runs on Windows 7 or better.



Verify IGRT setup accuracy in less than 5 minutes

KEY FEATURES

- ▶ Quick simple Winston-Lutz test for Image Guided Radiotherapy
- ▶ Analyze EPID radiation field exposures
- ▶ Analyze various shaping devices
- ▶ Report left/right, superior/inferior and anterior/posterior errors at configurable gantry, collimator and table angles
- ▶ Off-center laser marks used to test couch shifts

6mm tungston sphere enclosed within a 5cm acrylic cube, the QUASAR™ IsoCenter Cube is designed to provide information needed to clinically implement a modified Winston-Lutz test for IGRT accuracy.

Test end-to-end IGRT positioning accuracy for clinical treatment setups with 0.1 mm precision in less than 5 minutes. The test is performed by aligning a phantom containing radiopaque sphere with IGRT system, then capturing radiation field exposures with EPID. The test results are used to determine targeting accuracy for frameless SRS, SBRT, and IGRT treatments.

ANALYSIS SOFTWARE

- ▶ Import and analyze EPID images
- ▶ Configure gantry collimator and couch rotation parameters
- ▶ Export results for trending purposes
- ▶ Define parameter and threshold templates

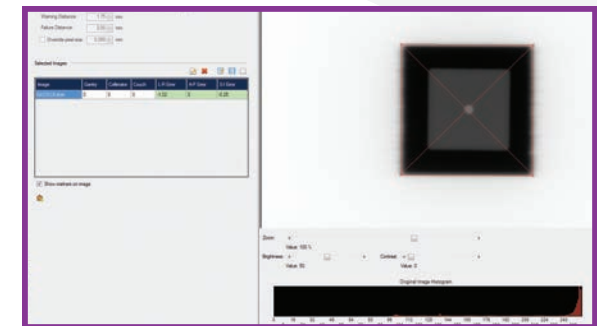

QUASAR™

PENTA-GUIDE

Daily IGRT QA to ensure OBI targeting accuracy



KEY FEATURES

- ▶ Enables daily testing to ensure on-board imaging targeting accuracy
- ▶ Daily test of 3D couch corrections
- ▶ Contains 5 low-density rings and hollow spheres which minimize high-density artifacts
- ▶ Includes FREE image analysis software to simplify CBCT QA testing
- ▶ Apply simple Pass / Fail acceptance criteria
- ▶ Testing does not infringe upon patient treatment time
- ▶ Daily test light field and laser alignment
- ▶ 1/4 mm accuracy

The QUASAR™ Penta-Guide QA Phantom is used for the commissioning and daily testing of Image-Guided Radiotherapy (IGRT) systems. The QUASAR™ Penta-Guide Phantom ensures the accuracy of linac-mounted image guidance systems, including cone beam CT (CBCT), x-ray volumetric imaging (XVI) and on-board imaging (OBI).

Minimize imaging artifacts by making use of the Penta-Guide's low-density objects to allow for rapid and easy daily testing of:

- ▶ 3D cone beam registration
- ▶ kV and MV system coincidence
- ▶ kV and MV projection images
- ▶ Laser and light field coincidence
- ▶ Remote table adjustments

DAILY QA

Used by a therapist every morning, testing takes little or no extra time and can be completed during normal daily equipment warm-up procedures.

QUASAR™

TILT PLATE

Verify image-guided shifts for six degree of freedom couches

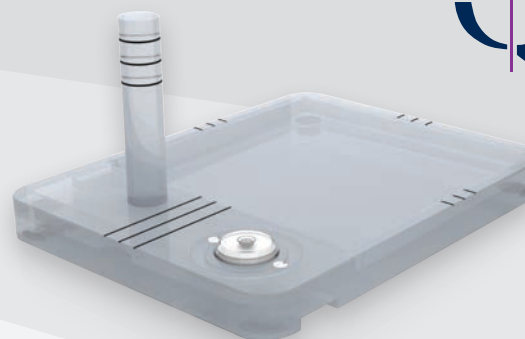

SPECIFICATIONS

- ▶ Tilt angles are: 0.75°, 1.25°, and 1.0°
- ▶ Turning the tilt plate in 90° increments varies the direction of the rotation corrections
- ▶ Compatible with the QUASAR™ Penta-Guide Phantom
- ▶ Features a precision cut out to accommodate most localization bars

The QUASAR™ Penta-Guide Tilt Plate is an easy and efficient way to verify couch corrections for six degree of freedom (6DoF) couches.

The QUASAR™ Penta-Guide Tilt Plate was designed as an accessory to the QUASAR™ Penta-Guide Phantom to facilitate the daily QA of linear accelerators equipped with 6 degree of freedom couches.

The QUASAR™ Penta-Guide Tilt Plate positions the QUASAR™ Penta-Guide Phantom at known rotation angles and displacements relative to the isocenter. With this device, users test rotation corrections and combined translation and rotation corrections on a 6DoF couch.

DAILY 6DoF QA

The central lines, in each group of three, align the centre of the Phantom with the laser isocenter for rotation only corrections. Other lines require translation and rotation corrections.

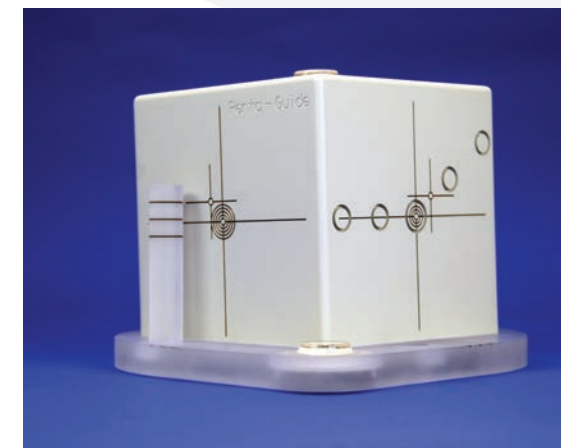

QUASAR™ WAND

Aligning the lasers to the true radiation isocenter



SPECIFICATIONS

- ▶ 7/16" (11.1125 mm) Steel BB embedded in acrylic wand
- ▶ XYZ Micro Stage for positioning wand
- ▶ Counterbalanced stand for ease of use
- ▶ Compatible with LINACs and EPIDs from multiple vendors
- ▶ Comes with a convenient storage and carrying case



The QUASAR™ Wand is the ideal tool to confirm a linear accelerator's true isocenter. It is quick and easy to set-up, and has micrometer adjustment for all three axes (x,y, and z planes). This facilitates the alignment with the true isocenter and the sharp laser marks on the wand are clear and definitive.

Peter A. Goyer, MS, DABR // Lewistown Hospital

IDENTIFY THE LINACS TRUE ISOCENTER

The QUASAR™ Wand is a Winston-Lutz device used in conjunction with the MV Beam and portal imager to identify the true radiation isocenter of the linear accelerator with submillimeter accuracy.

The primary advantage this device has over other similar products is that all 3 axes can be micro adjusted using the built-in micrometers. This allows the user to place the QUASAR™ Winston-Lutz Wand precisely at the radiological isocenter. From this position, users simply bring the lasers into alignment with the marks on the wand, thus tuning the lasers to the true radiation isocenter.



The fundamental benefit of this procedure will provide submillimeter agreement between the true radiological isocenter and the room lasers. While this type of apparatus is included in the purchase of SRS/SBRT packages, Modus QA has provided an economical alternative for those who want to achieve this level of accuracy without the expense of purchasing a SRS package.

QUASAR™ CpRESP

Precision fitted to ArcCHECK® cavity

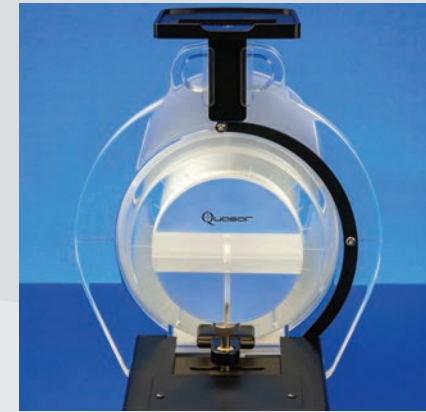

KEY FEATURES

- ▶ Simulate patient breathing inside a cylindrical diode array
- ▶ Stream patient-specific respiratory motion waveforms without any additional programming or customization
- ▶ Operate the phantom directly from a PC or laptop
- ▶ Communicate with phantom through local area network
- ▶ Interchangeable inserts for multiple testing applications can be rotated as they translate, creating 3D motion
- ▶ Compatible with motion tracking systems from multiple vendors
- ▶ Software license allows for unlimited usage and installation on unlimited computers

SIMULATE PATIENT BREATHING

The programmable QUASAR™ Cylindrical Respiratory Motion Phantom is designed to move a cylindrical insert in the superior/inferior direction within a cylindrical diode array. Interchangeable inserts are available for multiple testing applications, including imaging, planning, and delivery. Inserts can be rotated as they translate creating 3D motion.

A Chest Wall Platform is included with the Phantom. The platform moves in the anterior/posterior direction and is compatible with motion tracking systems from several different vendors.

The QUASAR™ Cylindrical Respiratory Motion Phantom is compatible with inserts designed for the QUASAR™ Respiratory Motion Phantom. It includes software to display, edit, and run waveforms.

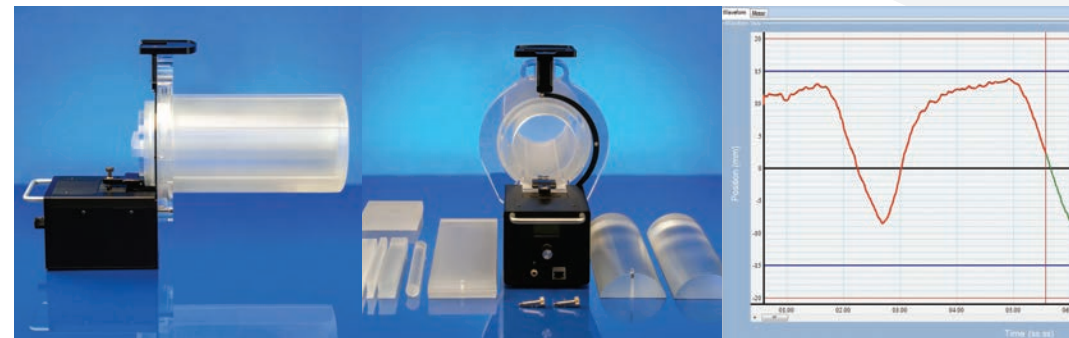

QUASAR™ PLATFORM

Add Multi-Directional Motion to Existing Stationary Phantoms



KEY FEATURES

- ▶ Accommodates phantoms weighing up to 20 kg on a 35 x 35 cm platform
- ▶ Generates lateral hysteresis motion for phase separation testing
- ▶ Simulates patient-specific respiratory and sinusoidal motion profiles
- ▶ Communicate with the phantom through local area network (LAN)
- ▶ Compatible with motion tracking systems from multiple vendors

SOFTWARE INCLUDED

The programmable QUASAR™ Respiratory Motion Platform comes with software which allows you to import, create, edit and save respiratory waveforms. Easily import patient-specific waveforms from a number of respiratory gating machines including Varian Real-time Position Management™ (RPM), Anzai, Cyberknife, Philips, Respiciens, and Siemens. Quickly create custom waveforms or import unique waveforms produced using tab delimited spreadsheet files. Conveniently edit waveforms using a wide range of functions include adjusting the amplitude, stretching or compressing the timeline and filtering out high frequency noise, low frequency drift and cardiac signals. The software is compatible with Windows 7 or better.

Adaptable dosimetric and nondosimetric QA system testing

QUASAR™ MP BODY

KEY FEATURES

- ▶ Dosimetric and non-dosimetric tests for end-to-end radiotherapy system testing
- ▶ Published pass/fail criteria for a number of tests in the TG 53 and TG 66 Reports
- ▶ Interchange inserts quickly and easily for many different tests
- ▶ Converts to an IGRT gating phantom with the addition of the QUASAR™ Programmable Respiratory Motion Assembly



The QUASAR™ Respiratory Motion Platform is designed to move your existing phantoms with programmable respiratory and sinusoidal motion profiles for patient-specific QA.

The Platform's unique multi-directional motion simulation capability allows it to move in the superior/inferior direction but can also generate a lateral hysteresis motion with amplitudes up to 1.0 cm. This allows testing with phase separation.

With a weight-bearing capacity of 20 kg, the QUASAR™ Respiratory Motion Platform can be used to move any QUASAR™ phantom and most third party phantoms.

The QUASAR™ Respiratory Motion Platform includes a Chest Wall Platform - moving in the anterior/posterior direction - which is compatible with motion tracking systems from several vendors.

The QUASAR™ Multi-Purpose Body Phantom is designed to test the complete radiotherapy system through a series of nondosimetric and dosimetric evaluations.

True to the original QUASAR™ Body Phantom developed by Jake Van Dyk at the London Regional Cancer Program, the QUASAR™ Multi-Purpose Body Phantom uses a wide variety of test objects in a solid acrylic oval to perform many of the nondosimetric quality assurance tests recommended by TG 53 and TG 66.

ADD IGRT GATING CAPABILITIES

Also available is the programmable QUASAR™ Respiratory Motion Assembly which can be used to easily convert the QUASAR™ Multi-Purpose Body Phantom into an IGRT gating phantom, thereby offering a cost-effective way to increase overall testing capabilities.



Verify IGRT plans and avoid gated treatment errors



KEY FEATURES

- ▶ Stream patient-specific respiratory motion waveforms without any additional programming or customization
- ▶ Operate the phantom directly from a PC or laptop
- ▶ Communicate with phantom through local area network
- ▶ Interchangeable inserts for multiple testing applications with the ability to rotate inserts as they translate to create 3D motion
- ▶ Compatible with a number of LINACS and motion tracking systems from several vendors
- ▶ Software license allows for unlimited usage and installation on unlimited computers
- ▶ Software architecture enables remote access

SIMULATE PATIENT BREATHING

The programmable QUASAR™ Respiratory Motion Phantom is designed to move a cylindrical insert in the superior/inferior direction within a body shaped oval.

Operate the phantom under software control in oscillation (programmable), rotation and position mode or under local control without a computer in rotation and position mode.

Interchangeable inserts are available for multiple testing applications, including imaging, planning, and delivery. An optional rotation stage allows inserts to rotate as they translate, creating 3D motion.

The programmable QUASAR™ Respiratory Motion Phantom includes a Chest Wall Platform, moving in the anterior/posterior direction, which is compatible with motion tracking systems from several different vendors.

MOTION QA SOFTWARE

Included with the phantom is the QUASAR™ Respiratory Motion QA Software application which allows you to import, create, edit and save respiratory waveforms.

Easily import patient-specific waveforms from a number of respiratory gating machines including Varian Real-time Position Management™ (RPM), Anzai, Cyberknife, Philips, Respisens, and Siemens.

Quickly create custom waveforms or import unique waveforms produced using tab delimited spreadsheet files.

Conveniently edit waveforms using a wide range of functions include adjusting the amplitude, stretching or compressing the timeline and filtering out high frequency noise, low frequency drift and cardiac signals.

The software is compatible with Windows 7 or better.

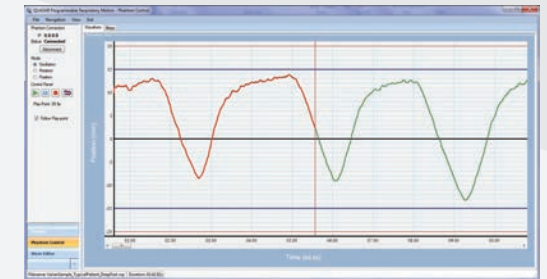

Acrylic Insert

Cedar Lung Tumour Inserts

4D CT Imaging Insert

PET CT Imaging Insert

Hollow Insert with Screw Cap

Cedar Solid Tumour Inserts

Rotation Adapter



Ion Chamber Measurements in Neutral Density Material



2D Dose Distribution in and around a Tumour within Lung Density Material (for Gafchromic film)

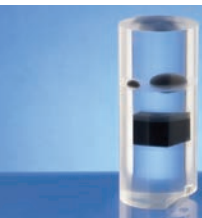

Verify the geometry and density in each phase of a 4D CT image



Acquisition, Reconstruction, Display and Registration 30 mm Sphere



Fill with liquid or gel for user-specific tasks



Imaging and Chamber Dosimetry with or without a Tumour within Lung Density Material



Add 3D motion to enable inserts to rotate as they translate with a 60° total range of motion (± 30° from the horizontal)



Modus QA

1570 North Routledge Park,
London, Ontario Canada N6H 5L6

Toll Free: +1 (866) 862-9682 (North America)

Phone: +1 (519) 438-2409

Fax: +1 (519) 643-0127

[e] info@modusQA.com

[w] www.modusQA.com

GET SOCIAL



modusQA.com