



Unit 4, Kimpton Trade & Business Centre
Minden Road, Sutton, Surrey, SM3 9PF
Tel: 020 8254 6802

IMPORTANT NOTE

Simulated crushed rock, simulated pebbles, simulated logs, or simulated driftwood, manufactured from special materials, are supplied with this appliance.

Do not use real crushed rock, pebbles, logs or driftwood, as this is dangerous. If the simulated crushed rock, simulated pebbles, simulated logs or simulated driftwood need renewing please obtain suitable replacements from a Nu-Flame stockist.

USE & MAINTENANCE INSTRUCTIONS

FOR NU-FLAME FIREBOXX SYSTEM (NATURAL GAS & LPG) FITTED WITH EVOLUTION *PLUS* BURNER. FOR DECORATIVE PURPOSES ONLY

NATURAL GAS MODELS: F350N fitted with an N2R+ (350) Evolution *Plus* Burner
F500N fitted with an N4R+ (500) Evolution *Plus* Burner
F720N fitted with N3R+(x2) (720) Evolution *Plus* Burners

LPG MODELS: F350L fitted with an L2R+ (350) Evolution *Plus* Burner
F500L fitted with an L4R+ (500) Evolution *Plus* Burner
F720L fitted with L3R+(x2) (720) Evolution *Plus* Burners

GENERAL

- a. This fire must be installed by a properly qualified (in accordance with National & Local Regulations) Installation Engineer.
- b. The connection of this appliance, and ventilation requirements (if any) are to be according to National & Local Codes.
- c. The chimney should be swept before the appliance is installed.
- d. Open fires are a hazard; it is recommended that a guard be fitted to provide protection for children, the elderly or infirm. (See National & Local Regulations if any.)
- e. This appliance is intended for decorative purposes only.
- f. Do not throw rubbish on, or attempt to burn any materials on this appliance. Any debris or foreign matter must be removed from the fire.
- g. The appliance should be serviced by a qualified engineer every 12 months.
- h. The Thermatronic Control System is a battery operated gas fire control system that uses a microprocessor to provide the working sequences needed by the fire, and when used with an oxy pilot has all the safety features required by law and CE approval.
- i. Commands are accepted by the microprocessor when buttons are pressed. An audible beep means that the command is received, and the push button should immediately be released.

IMPORTANT NOTES

- a. This appliance is fitted with an oxygen depletion sensing system, which automatically shuts off the gas supply to the main burner if the oxygen level in the room is depleted, due to a lack of primary air, or obstructed flue that would lead to incomplete combustion of the gas.
- b. In the event that the fire shuts down due to any reason, attempt to restart it. If there is a continuing problem call in a properly qualified specialist engineer.
- c. There are no user replaceable parts in this appliance except the 4 # AA batteries.
- d. The Fireboxx is supplied with batteries in a separate box that has a long lead which plugs into a socket on the standard electronics/battery box.
- e. This battery box is accessed at the left hand end of the Fireboxx (beneath a removal cover plate) and positioned with the connection lead connector at the top. Ensure that the lead wire does not contact the end of the burner pan by tucking the lead wires between the battery box and the left hand end of the Fireboxx, as shown on the drawing on page 6.
- f. On no account put batteries into the battery compartment of the receiver box. They must only be placed in the battery box situated at the left hand end of the Fireboxx, as shown on the drawing on page 6.
- g. Regularly inspect the purpose provided room ventilator (if fitted) to check that it is free from any obstruction.
- h. The chimney should be regularly checked to ensure that all the products of combustion are entering the flue & that there is no build up of soot. If there is, the appliance must be cleaned.
- i. Do not cover the ventilation holes in the top plate grille with fuel bed or any other material.

USING THE RADIO FREQUENCY CONTROL SYSTEM

Control can only be achieved if the handset is pointed at the fire. The red light will flash each time you press a button on the handset.

a. Ignition

Simultaneously press and hold the red button and the right upper button (linked by line) until a short acoustic signal confirms that the sequence has begun, then release the buttons. Continuous audible signals confirm that ignition is in progress. When pilot ignition is confirmed the motor will open the valve to maximum flame height – this takes about 30 seconds.

b. Flame Height Adjustment

Press the small flame button until the flame height is at the desired position. If you try to go beyond the preset low flame minimum height the main burner will turn off leaving the pilot burner alight (this is the standby position). You will learn from experience the preset low flame minimum height.

To relight the fire from the standby position, or to increase the flame height from low flame, press and hold the large flame button until the desired flame height is achieved. Please note that you can have the flame height anywhere between maximum and preset low. For fine adjustment simply tap the up or down arrows.

c. To Switch Off

Press the red/off button on the handset.

d. Manual Off Switch

If your handset is mislaid, or for some reason the batteries fail while the fire is running you can turn the fire off with the on/off switch located at the front right hand corner of the fire. This switch interrupts the thermocouple current to the control system and shuts down the fire immediately. This switch must be put back into the on position to relight the fire.

e. General

Battery replacement is recommended at the beginning of each heating season, or when an acoustic error message sounds during ignition.

Error Message - Long signals (0.8 second tone - 0.2 second break) during ignition - probable cause - batteries in receiver are nearly discharged.

Error Message - 5 second continuous tone - probable cause - cable disconnected or on/off switch on valve is in off position.

Batteries Receiver Box - 4 x AA good quality alkaline

Handset - 1 x PP3 good quality alkaline



RESETTING THE MERTIK MAXITROL LOGIC CIRCUITS (RADIO FREQUENCY CONTROL)

BASIC RESET

It sometimes happens that (such as when the handset buttons are pressed out of sequence) the fire stops working because the logic circuits get confused and need to be reset. To do this, simply remove the 4 x AA batteries from the Receiver Box (do not use metal tools to do this), wait for 1 minute and then refit the batteries. Wait for another minute and then point the handset at the fire and press the red/off button. Wait for another minute and then start the fire as normal. If the fire does not start repeat the resetting procedure. If the fire still does not work a Full Reset can be tried (see below).

Note: If an extended battery box has been supplied, and the lead has been unclipped from the battery box, do not let the lead terminals touch any metal parts, because voltage is still stored in the capacitors, which can cause a short circuit.

FULL RESET – TO BE USED IF A REPLACEMENT HANDSET IS OBTAINED

NOTE. On some burners such as the Fireboxx and “sunken” burners it is not possible for the user to access the Receiver Box to carry out a Full Reset. If the user cannot access the reset button on the Receiver Box a Qualified Installation Engineer will need to remove the burner to do so and this will involve disconnecting the burner from the gas supply.

If you obtain a new handset the control system will need to learn the handset's unique code via a Full Reset. Also, if the fire is not working and the Basic Reset (described above) has not worked a Full Reset can be carried out:

- Replace the batteries in the Receiver and Handset.
- Locate the Reset Hole on the side of the Receiver and using a pen press and hold in the Reset button until you hear two beeps. The first beep is short and the second beep is long. After the second beep release the Reset Button.
- Now on the Handset, within the next 20 seconds press the Small Flame Button until you hear two additional short beeps confirming the code is set in the Receiver.
- If you hear one long beep the Code as not been set so repeat the procedure.
- If the fire still does not work, the problem lies elsewhere.

Note: If an extended battery box has been supplied, and the lead has been unclipped from the battery box, do not let the lead terminals touch any metal parts, because voltage is still stored in the capacitors, which can cause a short circuit.

CLEANING THE FIRE

- Do not use a vacuum cleaner to clean the appliance.
- Gently remove the simulated pebbles, logs or driftwood one by one & remove soot deposits with a soft brush.
- The firebed granules should be as shown on the drawing on page 5. If they are not top up as required. Ensure that the granules are not obstructing the pilot cover assembly. If any further granules are required use only those supplied by Nu-Flame.
- Pebble, log & driftwood effect fires:** Re-lay as shown on the relevant drawing. **Do not add more simulated pebbles, logs or driftwood or change the firebed layout in any way.**



RECORD DATA TO BE COMPLETED & KEPT BY USER:

PLACE OF PURCHASE DATE

ADDRESS & TEL. NO.

.....

.....

APPLIANCE SERIAL NO.

INSTALLED BY GAS SAFE REG. NO

INSTALLATION & SERVICING INSTRUCTIONS

FOR NU-FLAME FIREBOXX SYSTEM (NATURAL GAS & LPG)
FITTED WITH EVOLUTION PLUS BURNER. FOR DECORATIVE PURPOSES ONLY

NATURAL GAS MODELS: F350N fitted with an N2R+ (350) Evolution Plus Burner
F500N fitted with an N4R+ (500) Evolution Plus Burner
F720N fitted with N3R+(x2) (720) Evolution Plus Burners

LPG MODELS: F350L fitted with an L2R+ (350) Evolution Plus Burner
F500L fitted with an L4R+ (500) Evolution Plus Burner
F720L fitted with L3R+(x2) (720) Evolution Plus Burners

THIS APPLIANCE MUST BE INSTALLED & SERVICED BY A PROPERLY QUALIFIED (IN ACCORDANCE WITH LOCAL & NATIONAL CODES) INSTALLATION ENGINEER.

IMPORTANT:

BEFORE PROCEEDING WITH THE INSTALLATION READ THESE INSTRUCTIONS CAREFULLY. THESE INSTRUCTIONS SHOULD BE KEPT IN A SAFE PLACE FOR FUTURE REFERENCE AND SERVICING DETAILS.

PRIOR TO INSTALLATION ENSURE THAT THE GAS TYPE & PRESSURE ARE AS STATED ON APPLIANCE DATA PLATE.

SIMULATED CRUSHED ROCK, SIMULATED PEBBLES, SIMULATED LOGS OR SIMULATED DRIFTWOOD, MANUFACTURED FROM SPECIAL MATERIALS, ARE SUPPLIED WITH THIS APPLIANCE. DO NOT USE REAL PEBBLES, LOGS OR DRIFTWOOD, AS THIS IS DANGEROUS. IF THE SIMULATED CRUSHED ROCK, SIMULATED PEBBLES, SIMULATED LOGS OR SIMULATED DRIFTWOOD NEED RENEWING PLEASE OBTAIN SUITABLE REPLACEMENTS FROM A NU-FLAME STOCKIST.

APPLIANCE DATA

GAS TYPE: SEE DATA PLATE.

BURNER: EVOLUTION PLUS

FLAME SAFETY: OXYGEN DEPLETION & FLAME FAILURE DEVICE STANDARD TO ALL MODELS.

APPLIANCE INLET WORKING PRESSURE: SEE DATA PLATE.

IGNITION: FROM REMOTE CONTROL SYSTEM

INLET CONNECTION: 8MM COMPRESSION FITTING.

NETT HEAT INPUT: SEE DATA PLATE.

Natural Gas Models (For G20 Gas*)

Firebox Model	Burner Model	Flue Classes	Category	Gas	Injector Size	kW Input Net High Flame	Burner Pressure (High Flame)
F350N	N2R+ (400)	Classes 1 & 2	I2H	G20	82/400	4.9	14 mbar
F500N	N4R+ (500)	Classes 1 & 2	I2H	G20	82/510	6.7	15mbar
F720N	N3R+(x2) (720)	Class 1 Only	I2H	G20	2 x 82/400	8.2	10.8mbar

LPG Models (For G31 Gas)

Firebox Model	Burner Model	Flue Classes	Category	Gas	Injector Size	kW Input Net High Flame	Burner Pressure (High Flame)
F350L	L2R+ (350)	Classes 1 & 2	I3P	G31	92/180	4.9	35.6mbar
F500L	L4R+ (500)	Classes 1 & 2	I3P	G31	92/260	6.1	13.2mbar
F720L	L3R+(x2) (720)	Class 1 Only	I3P	G31	2 x 92/180	8.8	29mbar

FLUE REQUIREMENTS

- a. Ensure that the builders opening, flue & hearth for the appliance are constructed from non-combustible materials, and conform to National Regulations and Local Codes.

Fireboxx Models F350N, F350L, F500N & F500L require a minimum flue diameter of 125mm or equivalent area (Class 2).

Fireboxx Models F720N, & F720L require a minimum flue diameter of 175mm or equivalent area (Class 1).

- b. Ensure that there is a smooth tapered transition from the fireplace opening to the flue. To achieve this a gather unit might need to be fitted, especially if a flue liner has been installed.
- c. The flue **MUST** be free of any obstructions. Any dampers or restrictors **MUST** be removed. Some dampers are impractical to remove; therefore they must be fixed in some way in the **OPEN** position.
- d. The chimney/flue should be swept prior to installation of the appliance.
- e. Ensure that only one fireplace is served by the flue system.
- f. Ensure that the chimney/flue is continuous from inlet to termination.
- g. Ensure that the chimney/flue is structurally sound, so that combustion products do not come into contact with combustible material outside the chimney.
- h. If the appliance is to be installed under a canopy, or is open on both sides, great care must be taken to ensure the configuration is correct. If in any doubt seek expert advice.
- i. **CHECK FLUE PULL.** Apply a smoke match to the flue opening at hearth level and observe smoke. If there is a definite flow into the flue aperture, proceed with installation. If there is not a definite flow into the flue aperture, preheat the flue for approximately 10 minutes and re-test. If there is still no definite flow towards the flue aperture the flue may need attention. **DO NOT FIT THE APPLIANCE, SEEK EXPERT ADVICE.**
- j. **It is very important to ensure that the fire is not subjected to intermittent flue downdraught, which can blow flames/gas down to the underside of the burner and cause overheating of the electronics.**

ADDITIONAL ROOM VENTILATION

THE CONNECTION, VENTILATION REQUIREMENTS (IF ANY) & INSTALLATION OF THE APPLIANCE MUST BE IN ACCORDANCE WITH NATIONAL REGULATIONS AND LOCAL CODES. IF IN ANY DOUBT WITH REGARD TO ANY VENTILATION REQUIREMENTS SEEK EXPERT ADVICE. **NOTE.** In the UK Model Numbers F350N, F500N, F350L & F500L do not require additional room ventilation. In Eire **all** Evolution Fires require additional room ventilation. For other countries refer to National Regulations and Local Codes.

APPLIANCE LOCATION

- a. The Fireboxx can be hearth mounted, shelf mounted, or flush mounted for Hole in the Wall applications using the support flanges supplied loose in the box, together with the fixing screws needed.
- b. Ensure that no naked flame or incandescent part of the fire bed projects beyond the vertical plane of the fireplace opening.

HEARTH

BS5871 and Building Regulations Document J call for a hearth to be provided if any flame, or incandescent part of the firebed is less than 225mm vertically above any carpet or floor covering. Where there is no carpet or floor covering in place, it is recommended that the 225mm distance be increased to 300mm, to make allowance for any future floor covering.

INSTALLATION OF THE APPLIANCE

Having ensured that the appliance application is correct and the requirements of the flue specification, ventilation demands and the gas supply are correct, proceed with the installation and assembly as follows:

- a. **In common with all other gas appliances, dirt and debris in the gas system can block the valve and gas injectors on this appliance, and faults caused by this are not covered by the guarantee. If you suspect that there is dirt and/or debris in the gas distribution system, fit a filter in the pipeline, before the burner gas installation connection.**
- b. Do not use jointing compound on any compression fittings on the burner or the control valve. The use of jointing compound on the compression fittings on this appliance will possibly invalidate the guarantee, as it can get into the control valve mechanism and cause it to malfunction.
- c. Ensure that there is an isolating valve in the gas supply line near the appliance.
- d. Check that all gas connections are sound. The appliance has been factory tested; however the connections may have been disturbed in transit or storage.
- e. Open fires are a hazard; it is recommended that a guard be fitted to provide protection for children, the elderly, or infirm (see National Regulations if any).
- f. Do not adjust or put out of action the spillage monitoring system (oxypilot), or change any of its parts.
- g. Use only original manufacturer's parts if any replacements are needed.
- h. If there is any concern about a pressure zone causing downdraught in certain wind conditions a suitable chimney cowl should be fitted
- i. Place the firebox in position, with the pilot to the rear, and remove the lift-out top grille.
- j. Fit the 4 # AA batteries in the battery box located at the left hand end of the Fireboxx, and replace the battery box with its connector lead connection at the top. Ensure that the lead wire does not contact the end of the burner pan by tucking the lead wires between the battery box and the left hand end of the Fireboxx, as shown on the drawing on page 6.
- k. Run the gas supply through the grommited hole in the bottom of the Fireboxx and connect it to the test point elbow inlet connection at the right hand end of the burner.
- l. Ensure the restrictor screw in the test point elbow is in the fully open position.
- m. Carry out a gas soundness check. You can use the test point connection on the test point elbow inlet connection for your manometer. (Inlet Pressure 20mbar.)
- n. Replace the top grille and position the battery cover plate as shown in the drawing on page 6.

ARRANGEMENT OF THE FUEL BED FILL

- a. **The burner tray is supplied with the burner already fixed in place.**
 - i. Cover the burner slot with Sellotape or similar to prevent vermiculite fill getting into the burner gas slots.
 - ii. Fill the burner tray all-round the burner block and then vigorously tap the sides of the outer box with the palms of your hands until the vermiculite settles, thus partly filling the void under the burner block.
 - iii. Repeat 2 above as necessary until the void under the burner block is full and then agitate more vermiculite into this void by using a screwdriver or similar.
 - iv. Once again top up the vermiculite to be approximately 3mm below the top of the burner block.
 - v. Remove the Sellotape or similar from the burner gas slots and ensure that the pilot assembly, top of the burner block and burner gas slots are totally clear of vermiculite granules.

!WARNING! No vermiculite or ceramics covering should be in the burner gas slots as this will block them and possibly cause the air intake (venturi) underneath to ignite and damage the electronic controls. If this happens there will be clear tell-tale signs to show this and the warranty will be void.

Failure to fill the void under the burner block will void the warranty and could result in the electronics overheating.

- b. Cover the burner block and the loose vermiculite with 5-7mm (approximately a single layer) of the simulated crushed rock, and shape off to the edge of the tray (see drawing below).

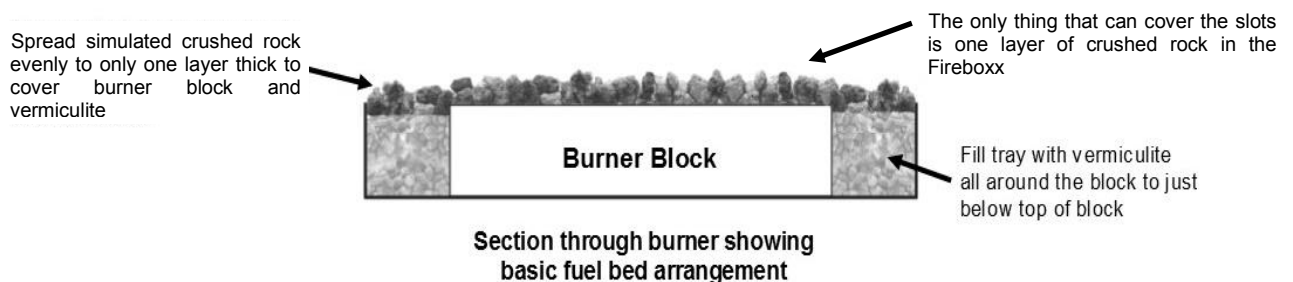

- c. The Fireboxx can be used with just the simulated crushed rock as the firebed. Nu-Flame can also supply premium quality simulated pebbles, simulated logs or simulated driftwood specially designed to be used with the Fireboxx and these can be positioned on top of the simulated crushed rock to give a range of different looks. If using these items please refer to the appropriate layout drawing located at the back of these instructions, paying attention to the fact that you must not cover any part of the gas outlet slots with the base layer of simulated pebbles/logs/driftwood.

Support Flange 15mm all round. Supplied loose for flush support if required

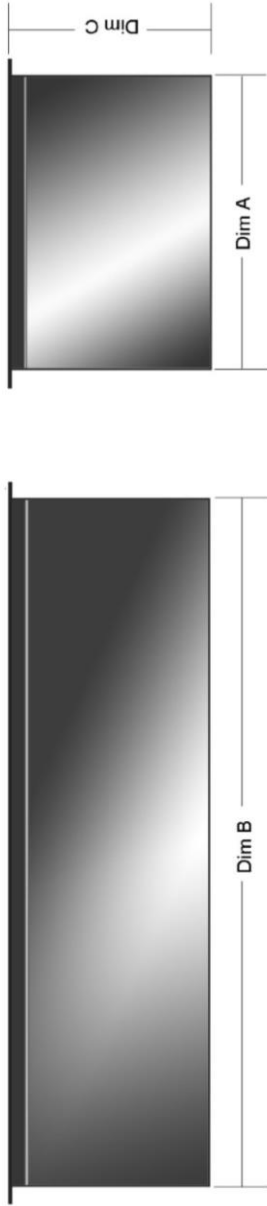

Pilot Assembly (at rear)



Battery Box
(tuck wires between battery and end of Firebox and put cover in position)

Model	Dim A (mm)	Dim B (mm)	Dim C (mm)	Cut Out size without flange (w x d - mm)	Cut Out size with flange (w x d - mm)
F350N/L	207	350	147	357 x 214	362 x 219
F500N/L	207	500	147	507 x 214	512 x 219
F720N/L	207	720	147	727 x 214	732 x 219

THERMATRONIC RADIO FREQUENCY CONTROL SYSTEM (MERTIK MAXITROL)

IMPORTANT NOTES

Temperature Limits of Electronic Components

- a. It is of great importance and absolutely necessary to ensure that the electronic control system components temperature does not rise above 60°C.
- b. ***It is also very important to ensure that the fire is not subjected to intermittent flue draught, which can blow flames/gas down to the underside of the burner and cause overheating of the electronics.***

Dampness

- a. All electronic equipment is sensitive to dampness and high humidity.
- b. The Thermatronic equipment must be installed in a completely dry place that does not access directly to outside air.
- c. If the fireplace has recently been rendered it must be allowed to completely dry out before the electronic equipment is installed.
- d. It is possible that dampness has occurred during storage of the appliance, so as a precaution we suggest placing the Firebox in a warm dry place for a while before installation

RESETTING THE MERTIK MAXITROL LOGIC CIRCUITS (RADIO FREQUENCY CONTROL)

BASIC RESET

It sometimes happens that (such as when the handset buttons are pressed out of sequence) the fire stops working because the logic circuits get confused and need to be reset. To do this, simply remove the 4 x AA batteries from the Receiver Box (do not use metal tools to do this), wait for 1 minute and then refit the batteries. Wait for another minute and then point the handset at the fire and press the red/off button. Wait for another minute and then start the fire as normal. If the fire does not start repeat the resetting procedure. If the fire still does not work a Full Reset can be tried (see below).

Note: If an extended battery box has been supplied, and the lead has been unclipped from the battery box, do not let the lead terminals touch any metal parts, because voltage is still stored in the capacitors, which can cause a short circuit.

FULL RESET – TO BE USED IF A REPLACEMENT HANDSET IS OBTAINED

NOTE. On some burners such as the Fireboxx and “sunken” burners it is not possible for the user to access the Receiver Box to carry out a Full Reset. If the user cannot access the reset button on the Receiver Box a Qualified Installation Engineer will need to remove the burner to do so and this will involve disconnecting the burner from the gas supply.

If you obtain a new handset the control system will need to learn the handset’s unique code via a Full Reset. Also, if the fire is not working and the Basic Reset (described above) has not worked a Full Reset can be carried out:

- a. Replace the batteries in the Receiver and Handset.
- b. Locate the Reset Hole on the side of the Receiver and using a pen press and hold in the Reset button until you hear two beeps. The first beep is short and the second beep is long. After the second beep release the Reset Button.
- c. Now on the Handset, within the next 20 seconds press the Small Flame Button until you hear two additional short beeps confirming the code is set in the Receiver.
- d. If you hear one long beep the Code as not been set so repeat the procedure.
- e. If the fire still does not work, the problem lies elsewhere.

Note: If an extended battery box has been supplied, and the lead has been unclipped from the battery box, do not let the lead terminals touch any metal parts, because voltage is still stored in the capacitors, which can cause a short circuit.

General

- a. The Thermatronic Control System is a battery operated gas fire control system that uses a microprocessor to provide the working sequences needed by the fire, and when used with an oxypilot has all the safety features required by law and CE approval.
- b. Commands are accepted by the microprocessor when buttons are pressed. An audible beep means that the command is received, and the push button should immediately be released.

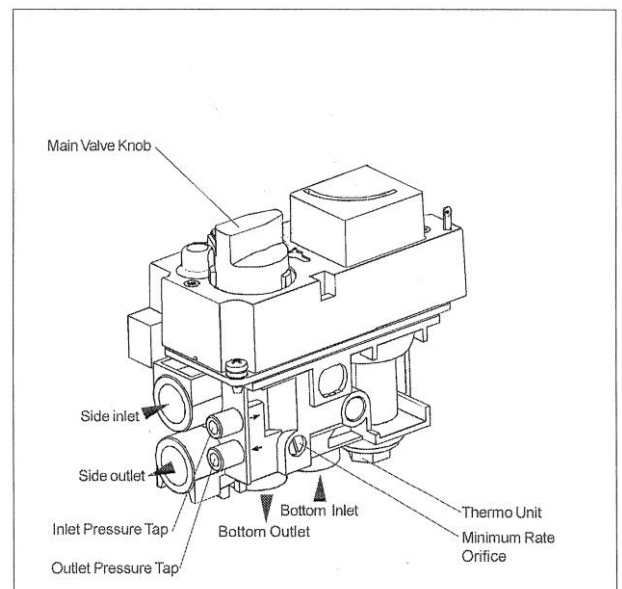

Combination Control GV60 Connections

GV60 and Mertik Maxitrol Cables with Layout Options

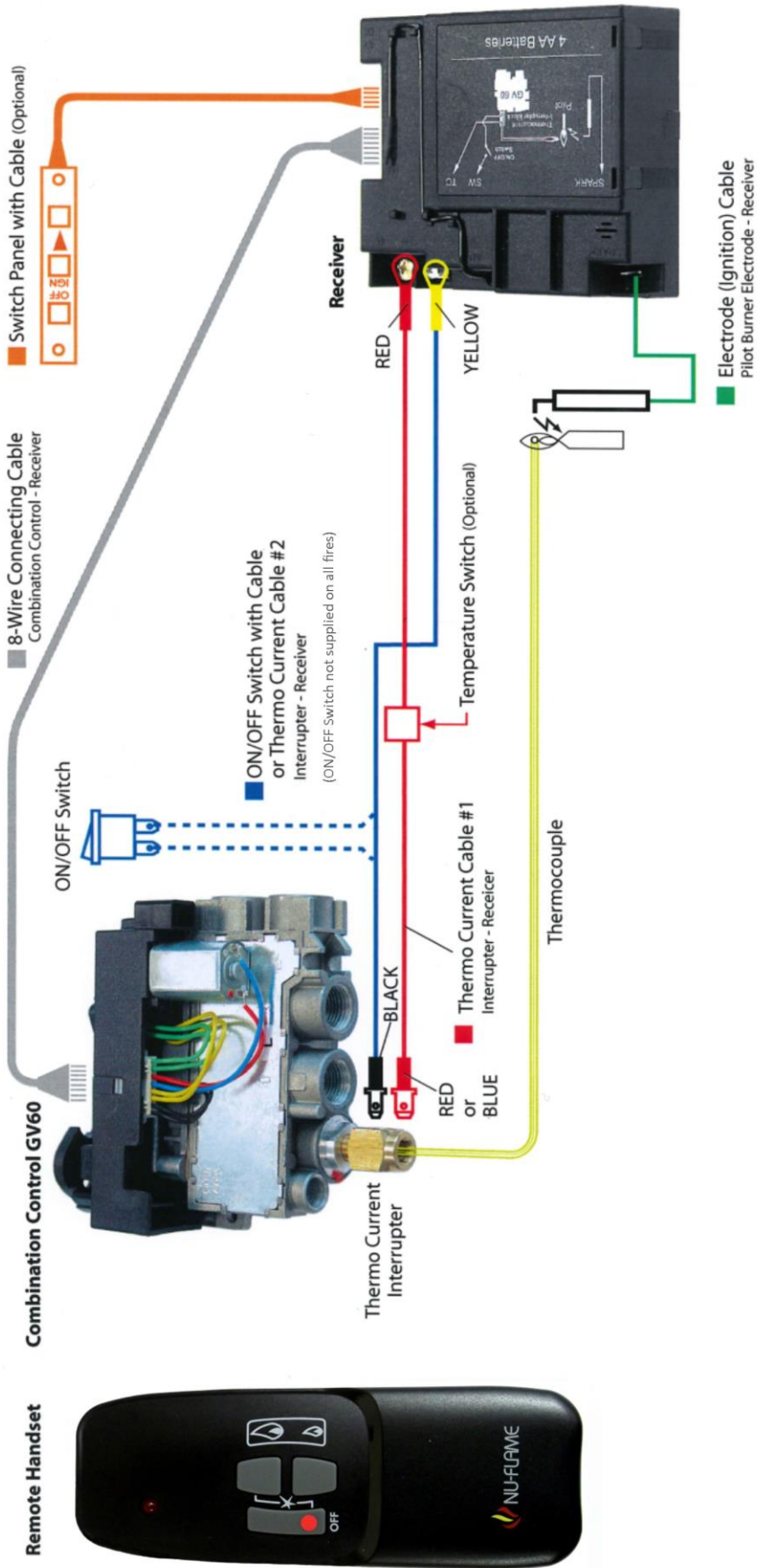

Important Notes

- a. This appliance is fitted with an oxygen depletion sensing system which automatically shuts off the gas supply to the main burner if the oxygen level in the room is depleted, due to lack of air or an obstructed flue.
- b. If the fire shuts down for any reason, attempt to re-start it. If there is a continuing problem call in a specialist engineer.
- c. There are no user replaceable parts in this appliance except the batteries.

COMMISSIONING THE FIRE

- a. Close all doors and windows, check operation of controls and burn for 5 minutes. Test for spillage of the flue products using a smoke match. If there is a small amount of spillage, run the fire for a further 10 minutes and re-test for spillage. If there is still spillage after the second test, DISCONNECT THE FIRE AND SEEK EXPERT ADVICE.

NOTE. If there are extractor fans in the room or adjacent rooms, these must be running at full speed setting with all interconnecting doors left OPEN.

- b. A smell may be experienced when the appliance is first commissioned. This is due to the new components of the fire. These odours will cease after the first few hours of burning.

SPECIAL NOTES

- a. This fire should be serviced every 12 months to ensure safe operation.
- b. Servicing and spares are available from your stockist.
- c. The fire may smell for the first few hours. This is due to the newness of the components and will cease in a few hours. If it does not consult your dealer straight away.
- d. Open fires are a hazard; it is recommended that a guard be fitted to provide protection for children, the elderly, or infirm (see National Regulations, if any).
- e. This appliance must never be cleaned with a vacuum cleaner.
- f. Debris and soot should be cleaned from the fire with a soft brush.
- g. Regularly check that the fixed air supply (if applicable) is free of any obstructions.
- h. ***IF THE FIREBED MATERIAL IS REPLACED USE ONLY MATERIAL SUPPLIED BY THE MANUFACTURER. FINER GRANULE SIZES ARE NOT SUITABLE.***

Note. SEEK EXPERT ADVICE IF YOU ARE UNSURE OF ANY POINTS REGARDING THE SAFE USE OF THIS APPLIANCE.

FAULT FINDING GUIDE. SYMPTOMS AND POSSIBLE CAUSES

1. NO SPARK

- Pilot light damaged, or too far away from Electrode, or too close.
- Electrode retaining lock nut has become loose, and needs to be tightened.
- Ignition lead has become detached from electrode and needs reconnecting.
- Electrode is damaged and needs to be replaced.
- Soot on the Pilot assembly and shorting spark. Clean this area with a soft brush.
- Faulty ignition lead. Replace.

2. SPARK IS VISIBLE BUT PILOT WILL NOT LIGHT

- Check that there is gas to the appliance.
- Ensure that isolating valve or restrictor elbow is in the OPEN position.
- Valve inlet has become blocked with debris. Clean.
- Pilot injector blocked. Clean.

3. PILOT FLAME SHORTENS, OR GOES OUT, WHEN MAIN BURNER LIGHTS

- This indicates insufficient gas pressure to the appliance. Check for debris obstruction.
- Check that there are no acute bends in the supply pipe and ensure that the correct diameter supply pipe has been used.
- Check pressure setting.

NOTE. If the appliance has been connected to a supply servicing another appliance the supply pipe may not have sufficient capacity to serve both appliances. Seek advice.

4. PILOT GOES OUT AT REGULAR INTERVALS

- Check that thermocouple is not loose. (It should only be nipped up as it is just an electrical connection.)
- Thermocouple is damaged and needs replacing.
- Thermocouple operated magnetic valve faulty – replace gas valve.

5. BLUE FLAME

- It normally takes 20 minutes for the fire to reach correct working temperature, by which time most of the blue flame should have gone. Continuous blue flame is caused by poor coal layout or excessive updraught of the flue. Seek advice from your stockist.
- Poor gas pressure will also cause blue flame. Check gas pressure.

6. POOR FLAME PICTURE

- Check gas pressure.
- Ensure that there are no obvious obstructions to gas supply pipe.
- Re-lay the simulated pebbles logs or driftwood as shown in the relevant drawing.

SERVICING INSTRUCTIONS

IMPORTANT: Turn OFF gas supply before servicing commences.

1. Remove all debris and dust from fire. **DO NOT USE A VACUUM CLEANER TO DO SO.**
2. If you have them on your fire remove any simulated pebbles, logs or driftwood from burner tray and gently dust off with a soft brush.
3. Disconnect gas supply and remove burner tray assembly.
4. Carefully remove and retain the firebed material. **IF IT IS TO BE REPLACED USE ONLY MATERIAL SUPPLIED BY THE MANUFACTURER. FINER GRANULE SIZES ARE NOT SUITABLE.**
5. Check Pilot and Gas valve assembly for gas soundness. Continue with service as required.
6. When replacing the vermiculite and re-laying the firebed material please refer to the ARRANGEMENT OF FUEL BED FILL section commencing of these instructions.

Nu-Flame Warranty and Repair Procedure

Nu-Flame fires are guaranteed for 1 year from the date of purchase. During that time our guarantee is to repair at our option, or replace at no charge a fire that proves to have faulty components or workmanship.

Telephone Help Line. In the event of a problem with a fire the first course of action should be to telephone our technical department on 020 8254 6802 during normal working hours 9 - 5.30 Monday - Friday (closed 1 - 1.30). If appropriate this should be done before the installer leaves site as we may well be able to resolve the problem over the phone and in any event it will save the installer a return visit to site. If we are not able to resolve the problem over the phone we will ask you to return the fire, and will log your details and give you a return reference number.

Return The Fire. It is a condition of the warranty that if we request you to return the fire to the factory, at the outset of any problem, you do so. This is both for safety reasons and due to the fact that we have the trained staff and necessary spares to carry out the repairs. The burner can then be thoroughly inspected and any signs of installation faults can be reported back to you. After any repair work is carried out the flow rates can be checked and re-set if necessary in order to fully comply with CE approval.

Note: It is a condition of the warranty that you do not return any parts to us unless we request you to do so. For example if we request that the burner only is returned and you send the entire appliance, the fuel bed and other items could be damaged or lost during the return delivery to us. We will not be liable for any such breakages, or losses.

Under no circumstances should any attempt be made to repair the burner on site without our express knowledge and approval during the warranty period.

This guarantee is given subject to the following provisions:

1. That the installation is carried out by a Gas Safe registered installer (we may require their registration details).
2. That the appliance is installed and used in accordance with our Installation & User instructions.
3. That the gas supply pressure at the appliance is not more than 3mbar below the gas pressure stated on the data plate when the appliance is running on high flame, with any other major gas appliances also running.
4. That the fireplace and flue system conform to relevant local codes, building regulations and British Standards.
5. This Guarantee is not transferable and relates to the original installation only.
6. The appliance has not been subject to misuse or accident or been modified or repaired by any person other than the authorised employee or authorised representative of Nu-Flame Ltd.
7. The Record Data section on the front of the Installation & Servicing Instructions is to be completed on installation.
8. Nu-Flame Ltd accepts no liability for any consequential loss or damage arising from the use or failure of the product or any information provided, including, but not limited to, economic or financial loss, damage to peripheral equipment or products, loss of use, productivity or time.
9. That the serial no. data plate on the burner is intact.

This guarantee in no way reduces your statutory rights.

Chargeable Repairs During and After the Warranty Period

If a repair is chargeable during the warranty period, due to installation faults we will inform you and where possible give you a quote, or if this is not possible, a price guide before starting work. We cannot always give a firm cost until we commence the repair as it is not always possible to tell which components have been damaged.

MODEL F350

LAYOUT FOR RECOMMENDED F350 SIMULATED PEBBLE SET AVAILABLE FROM NU-FLAME

Identify the simulated pebbles in the set by comparing them to the drawings below and then lay them in accordance with the pattern shown.

It is important to leave spaces of 15mm - 20mm between the simulated pebbles to ensure good secondary aeration. **Do not add further simulated pebbles.**

BASE LAYER

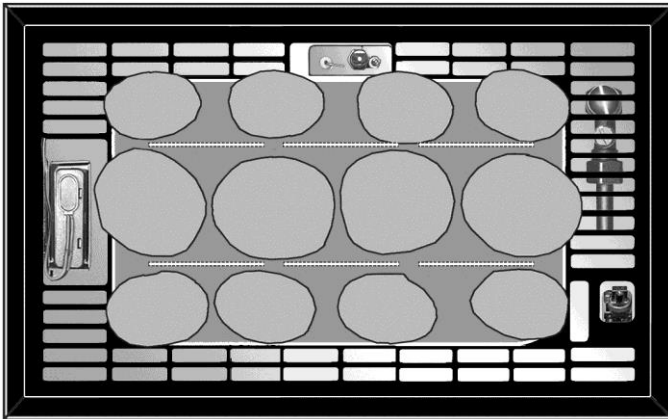

Do not cover any part of the gas outlet slots with the base layer of simulated pebbles. The gas outlet slots will be under the simulated crushed rock firebed, but will be easy to locate.

Ensure that the ventilation slots in the top grille are not obscured by the base layer of simulated pebbles.

TOP LAYER

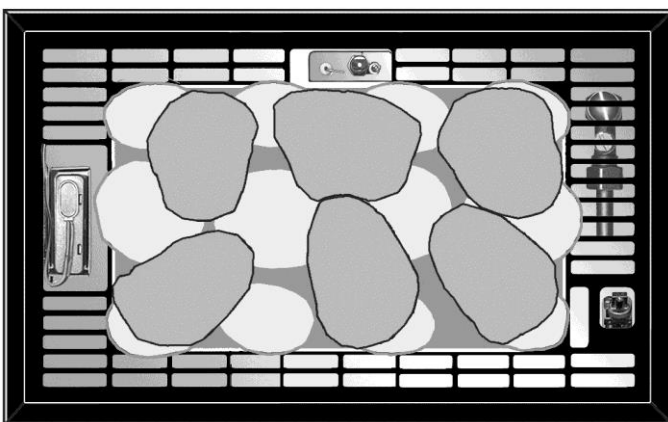

Run the fire for approximately 10 minutes and then, if required, adjust simulated pebbles to give desired effect.

MODEL F350

LAYOUT FOR RECOMMENDED F350 SIMULATED LOG OR DRIFTWOOD SET AVAILABLE FROM NU-FLAME

Identify the simulated logs/driftwood in the set by comparing them to the drawings below and then lay them in accordance with the pattern shown.

Do not add further simulated logs/driftwood.

BASE LAYER

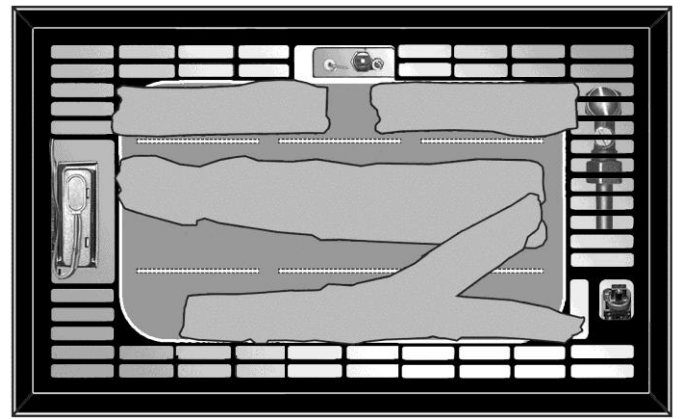

Lay the base layer of simulated logs/driftwood in such a way as to minimise the area of gas outlet slots covered. These slots will be under the simulated crushed rock firebed, but will be easy to locate. **Note: The branch of one base layer log are resting on another log so the slots are less covered than they look in the above illustration.**

Ensure that the ventilation slots in the top grille are not obscured by the base layer of simulated logs/driftwood.

TOP LAYER

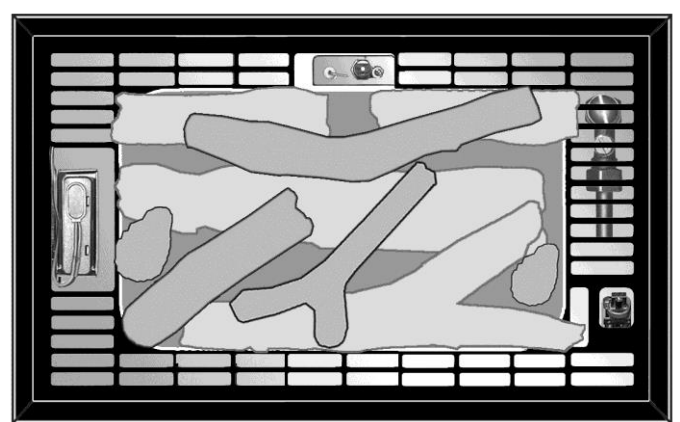

Run the fire for approximately 10 minutes and then, if required, adjust simulated logs or driftwood to give desired effect

MODEL F500

LAYOUT FOR RECOMMENDED F500 SIMULATED PEBBLE SET AVAILABLE FROM NU-FLAME

Identify the simulated pebbles in the set by comparing them to the drawings below and then lay them in accordance with the pattern shown.

It is important to leave spaces of 15mm - 20mm between the simulated pebbles to ensure good secondary aeration. **Do not add further simulated pebbles.**

BASE LAYER

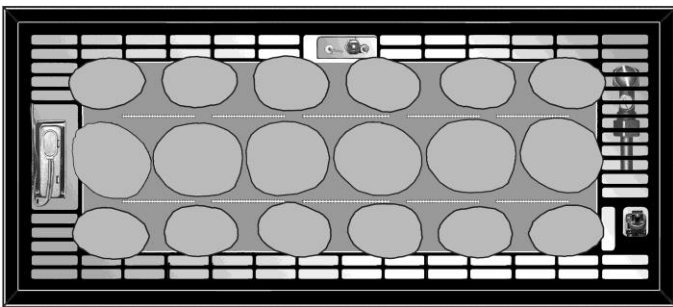

Do not cover any part of the gas outlet slots with the base layer of simulated pebbles. The gas outlet slots will be under the simulated crushed rock firebed, but will be easy to locate.

Ensure that the ventilation slots in the top grille are not obscured by the base layer of simulated pebbles.

TOP LAYER

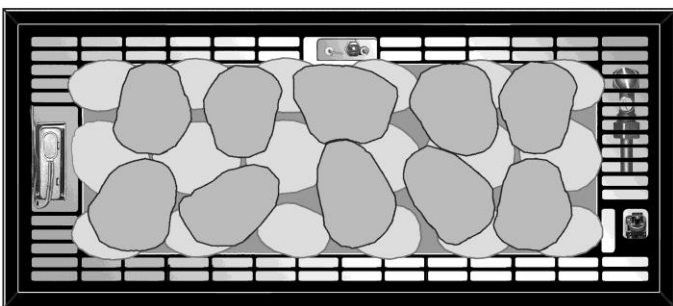

Run the fire for approximately 10 minutes and then, if required, adjust simulated pebbles to give desired effect.

MODEL F500

LAYOUT FOR RECOMMENDED F500 SIMULATED LOG OR DRIFTWOOD SET AVAILABLE FROM NU-FLAME

Identify the simulated logs/driftwood in the set by comparing them to the drawings below and then lay them in accordance with the pattern shown.

Do not add further simulated logs/driftwood.

BASE LAYER

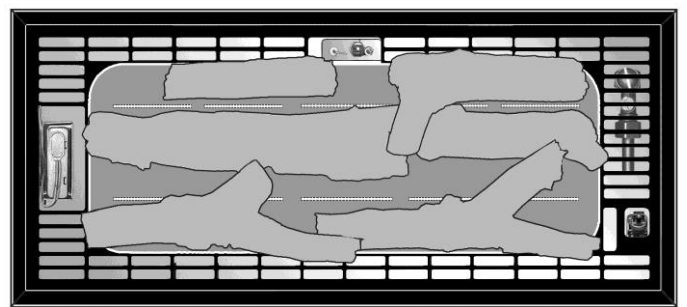

Lay the base layer of simulated logs/driftwood in such a way as to minimise the area of gas outlet slots covered. These slots will be under the simulated crushed rock firebed, but will be easy to locate. **Note: The branches of some base layer logs are resting on other logs so the slots are less covered than they look in the above illustration.**

Ensure that the ventilation slots in the top grille are not obscured by the base layer of simulated logs/driftwood.

TOP LAYER

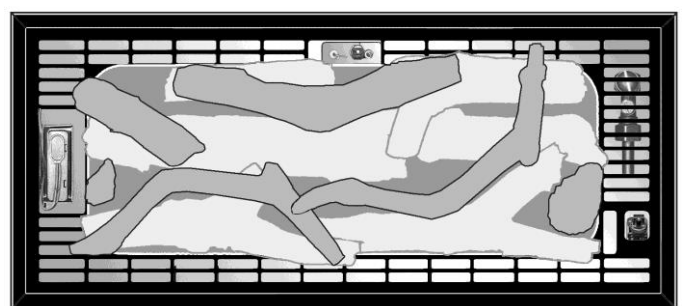

Run the fire for approximately 10 minutes and then, if required, adjust simulated logs or driftwood to give desired effect.

MODEL F720

LAYOUT FOR RECOMMENDED F720 SIMULATED PEBBLE SET AVAILABLE FROM NU-FLAME

Identify the simulated pebbles in the set by comparing them to the drawings below and then lay them in accordance with the pattern shown.

It is important to leave spaces of 15mm - 20mm between the simulated pebbles to ensure good secondary aeration. **Do not add further simulated pebbles.**

BASE LAYER

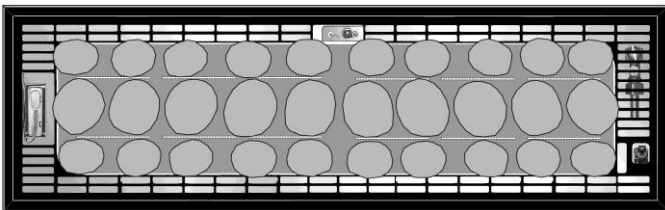

Do not cover any part of the gas outlet slots with the base layer of simulated pebbles. The gas outlet slots will be under the simulated crushed rock firebed, but will be easy to locate.

Ensure that the ventilation slots in the top grille are not obscured by the base layer of simulated pebbles.

TOP LAYER

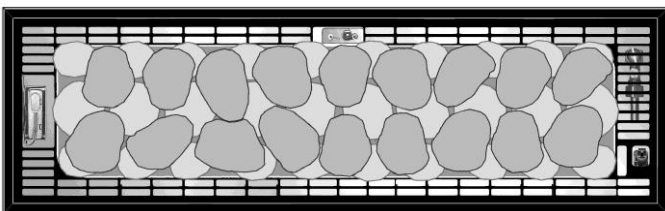

Run the fire for approximately 10 minutes and then, if required, adjust simulated pebbles to give desired effect.

MODEL F720

LAYOUT FOR RECOMMENDED F720 SIMULATED LOG OR DRIFTWOOD SET AVAILABLE FROM NU-FLAME

Identify the simulated logs/driftwood in the set by comparing them to the drawings below and then lay them in accordance with the pattern shown.

Do not add further simulated logs/driftwood.

BASE LAYER

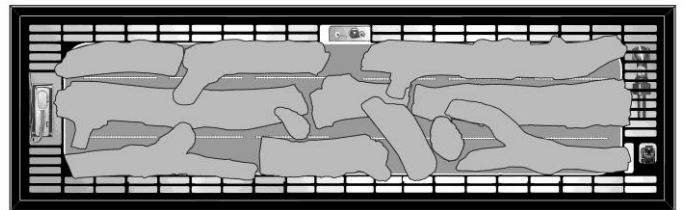

Lay the base layer of simulated logs/driftwood in such a way as to minimise the area of gas outlet slots covered. These slots will be under the simulated crushed rock firebed, but will be easy to locate. **Note: The branches of some base layer logs are resting on other logs so the slots are less covered than they look in the above illustration.**

Ensure that the ventilation slots in the top grille are not obscured by the base layer of simulated logs/driftwood.

TOP LAYER

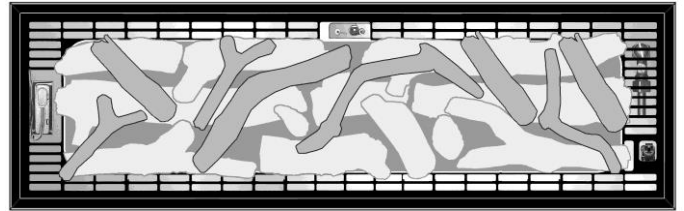

Run the fire for approximately 10 minutes and then, if required, adjust simulated logs or driftwood to give desired effect.

EU DECLARATION OF CONFORMITY

EU Declaration of Conformity

Name of Manufacturer : Nu-Flame Ltd
Address of Manufacturer : Unit 4
: Kimpton Trade & Business Centre
: Minden Road
: Sutton
: Surrey
: SM3 9PF

Telephone : 020 8641 9992

Manufacturing Location : As above

**This declaration of conformity is issued under the sole responsibility of the manufacturer
Above for:**

Product : Fireboxx series
Certificate Number : 18GR0302/00

**The objects of the declaration described above are in conformity with relevant harmonised
legislation**

Regulation (EU) 2016/426 relating to appliances burning gaseous fuels

The harmonised standards and technical specification have been applied

Where the Essential Requirements of the GAR have been met and approved by Notified Body:

Responsible Test House : Kiwa Nederland B.V.
Address : Wilmersdorf 50
: P.O. Box 137
: 7300 AC Apeldoorn
: The Netherlands

Authorised Signature of Manufacturer: 

Date of Issue: 21st April 2018