

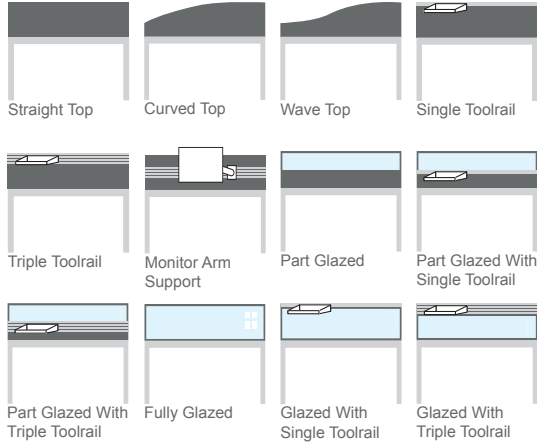

“Sprint screens are a modern, stylish and cost effective space dividing solution with a choice of white, silver or graphite grey frames. Available in desk mounted and freestanding versions, Sprint screens are constructed with a 30mm aluminium frame and top options that include straight, curved and wave.”

DESK MOUNTED



LINKING OPTIONS

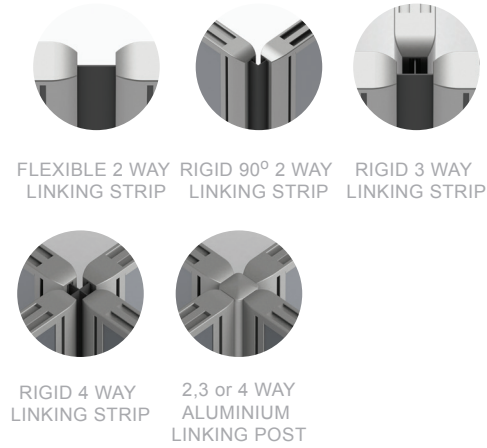

FREESTANDING

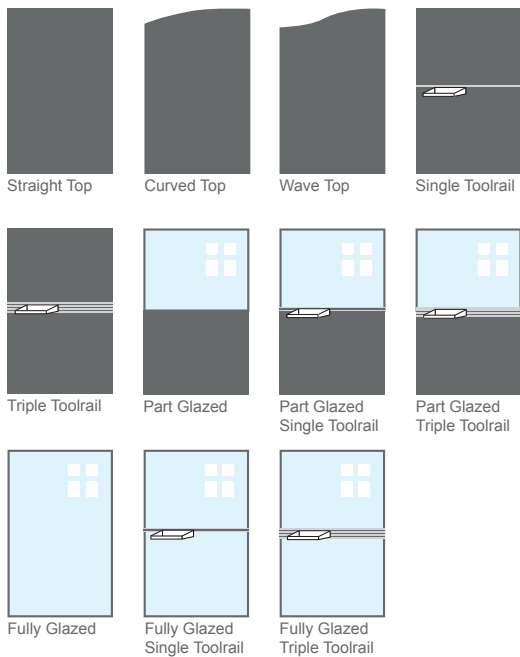

FEATURES



SCREENEN TEK INTERNATIONAL LTD
 Chapel Lane Business Park
 Coppull, Chorley
 Lancashire, PR7 4NB

T: 01257 791451
 F: 01257 794979
 sales@screentek.co.uk
 www.screentek.co.uk

SPRINT