

INSTALLATION, OPERATION &
MAINTENANCE INSTRUCTIONS



BELGRAVIA

Classic &
Natural

Contents:	Page
1. General	3
1.1. General Description	3
1.2. Receipt and Preparation	3
2. Installation	4
2.1. Removal of Access Panel	4
2.2. Transit Protection	4
2.3. Removing Motor Plate	5
2.4. Change of Handing	6
2.5. Reversal of Airflow	7
2.6. Wiring	8
2.7. Electric Motor Protection	8
3. Electrical Data	9
3.1. Control Wiring	10
3.2. Motor Wiring	10
3.3. Common Control Options	10
3.4. Thermostatic Operation	10
3.5. Switch Operation	10
4. Maintenance	11
4.1. General	11
4.2. Filter	11
4.3. Coil	11
4.4. Fan Set	11
4.5. Fusing	11
4.6. Spares	11
5. Fault Finding	12
5.1. No Fan Operation	12
5.2. No Heating	12
6. Waste Electrical and Electronic Equipment (WEEE) Directive	12
6.1. WEEE Marking	12
6.2. Information for Customers	12

1. GENERAL

1.1 GENERAL DESCRIPTION

This manual covers the 'Classic' and 'Natural' models of the Belgravia Fan Convecter range. 'Classic' units are the cabinet type intended for either vertical or horizontal mounting. 'Natural' models are free convection units for vertical mounting. Controls can be contained within the casing to give a clean outline.

The units can be supplied with internal grilles for visible surface mounting types or with plenum and/or spigot connections for concealed mounting in ceiling or wall space, when short duct connections may be required to serve the heated space via optional loose grille assemblies.

The 'Natural' unit possesses no motor plate as it relies upon buoyancy driven airflow through the casing. The following sections relating to the motor plate and its associated controls do not apply to this type of unit.

1.2 RECEIPT AND PREPARATION

The units are wrapped and display the SPC works order number, model reference, site reference (where appropriate), handing and site details. Installation, operation and maintenance instructions, together with wiring and any special instructions are supplied with the unit.

On receipt, check that all details are correct to the Customer Schedules prior to opening packaging. Damage should be reported to the Carrier and to SPC Office immediately.

It is recommended that packaging is kept in place and the units stored in a safe area until the necessary services are completed, in order to avoid the possibility of damage on site.

This document and wiring diagram supplied should be kept with the unit until electrical installation is complete.

2. INSTALLATION

2.1 REMOVAL OF ACCESS PANEL

Three methods of fixing access panels are employed:

1. Stud fixing is the standard fixing method. Access Panel mounted concealed studs are retained by case mounted spring clips. These are released by pulling the bottom of the panel outwards.
2. Tamperproof fixings designated TAP on order paperwork. Where these are supplied, they should be released with a quarter turn using the Allen Key provided.
3. Lock fixings, designated LAP on order paperwork. These are released with a quarter turn using the key(s) supplied.

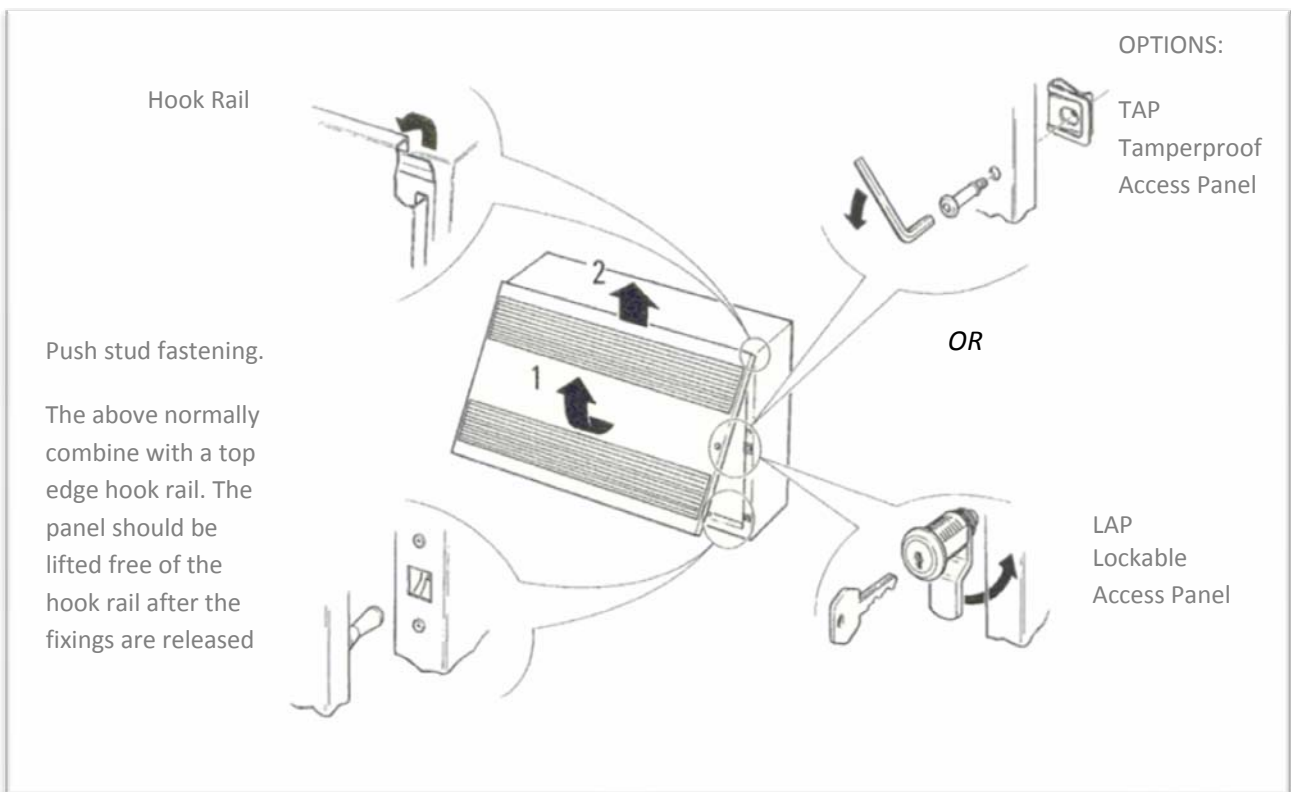

2.2 TRANSIT PROTECTION

If despatched with a Polystyrene block fitted between side wall & void bracket, this should be removed before installation.

2.3 REMOVING MOTOR PLATE

IMPORTANT: ISOLATE UNIT ELECTRICALLY AT MAINS CONTROLS.

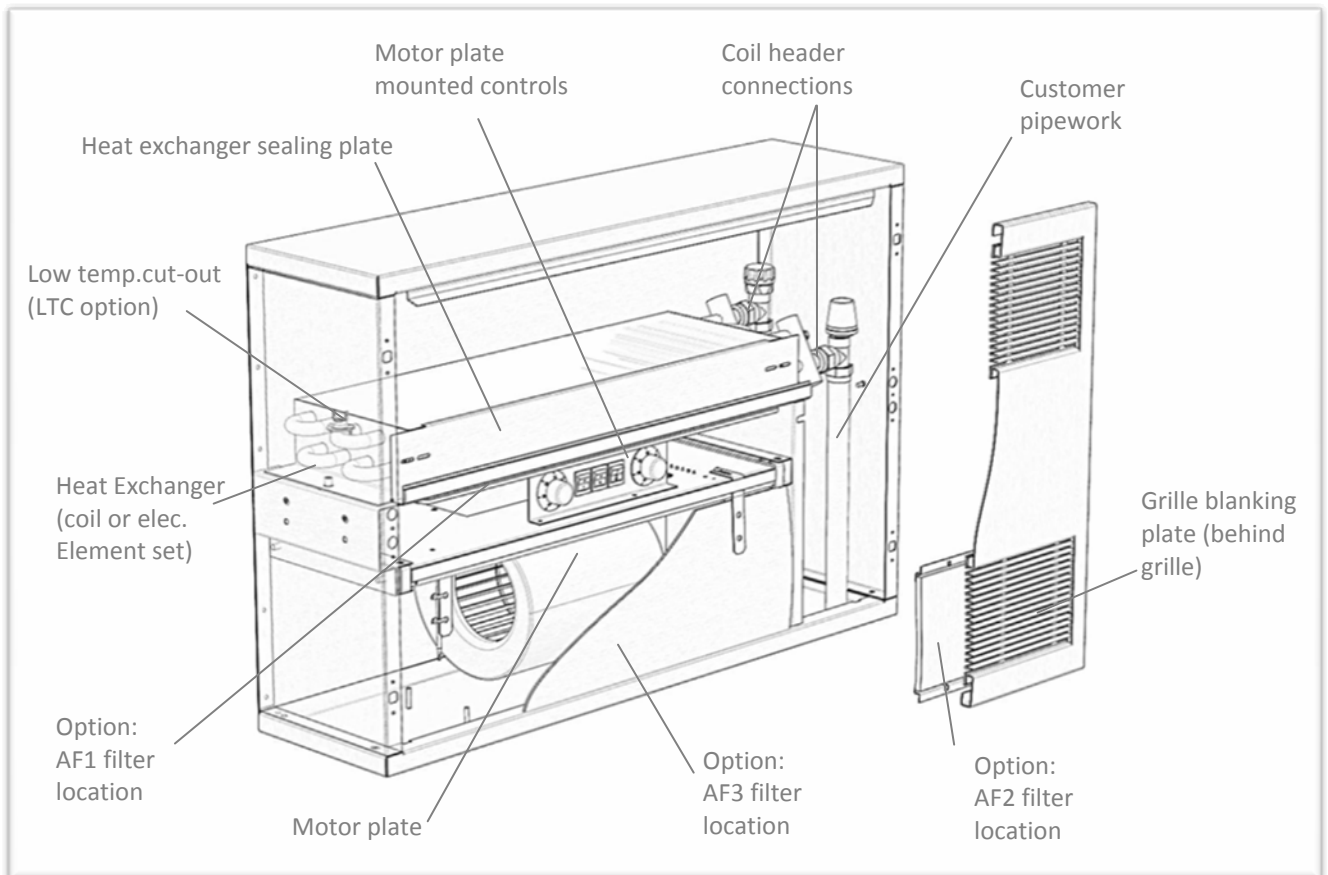

- Remove front access panel.
- Disconnect plug/socket connections from motor plate.
- Slide out motor plate, taking care not to damage fan impellers in any way during this procedure, or in the replacement.
- On ceiling mounted applications, the motor plate is retained by bolts through the motor plate & mounting bracket.
- Ensure motor plate is adequately supported before releasing the bolts.

o

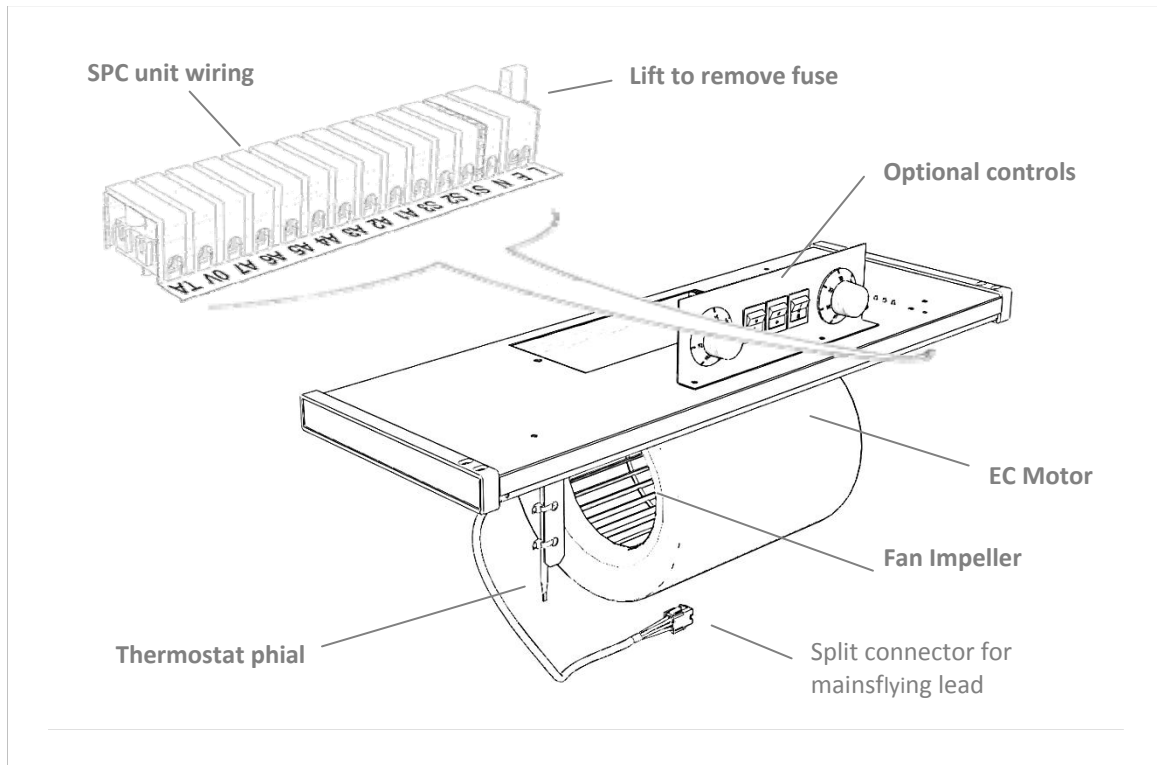

2.4 CHANGE OF HANDING

Unless otherwise specified all units will be supplied with heat exchangers having the connections at the Right hand end.

If it is necessary to reverse this handing on site for most units this is easily achieved by following these instructions:

- o Remove the front access panel and slide out motor plate. Unscrew the two M6.0hex head screws securing the heat exchanger, and remove, taking care that no damage to the fin block occurs. The foam on the back of the heat exchanger will have to be removed & new foam fitted on the opposite side.
- o Unscrew the four x M5.0 nuts securing the two heat exchanger support brackets and remove. Pull off the self-adhesive sealing felt from edge of long support (Void) bracket and replace it on the opposite edge. Reposition brackets over the nuts finger-tight only
- o Remove the two screws securing the heat exchanger sealing plate*, and refit along the opposite side. Tighten the mounting bracket fixing nuts. Replace the heat exchanger and secure
- o On units with bottom front grilles it is necessary to relocate the sealing plate(found behind the grille at one end) to the opposite end of the front panel
- o On units with bottom rear spigots this sealing plate is bolted to the heat exchanger support bracket and must be removed and bolted to the opposite flange, which will correctly position it when the support bracket is positioned at opposite end of casing

* In certain cases depending on the type of coil fitted, the heat exchanger sealing plate is welded to the coil so change of handing will not be possible.

2.5 REVERSAL OF AIRFLOW

The procedure for reversing the direction of airflow is similar to the reversing of pipe handing:

NOTE: Inbuilt thermostats should not be used on reverse airflow or for ceiling mounted applications.

Remove the front panel, motor plate and heat exchanger

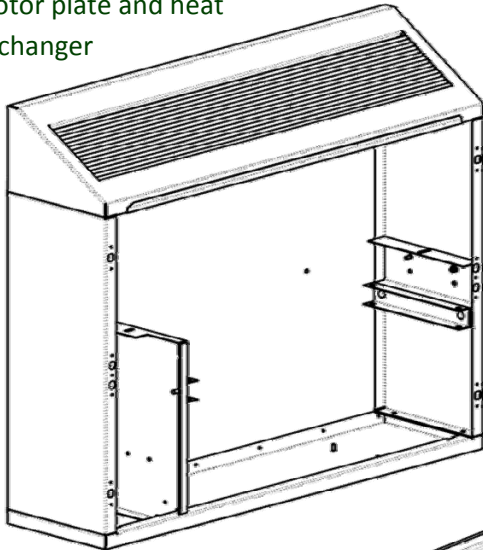

Remove void & non-void brackets, remove foam from edge of void bracket & from back of heat exchanger rotate both brackets 180°

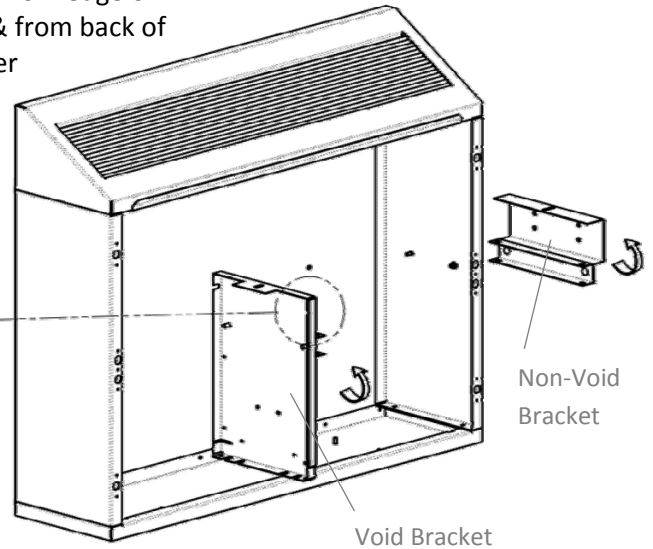
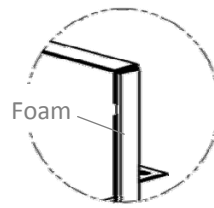

Void blanking plate (if fitted)

Drill holes as required

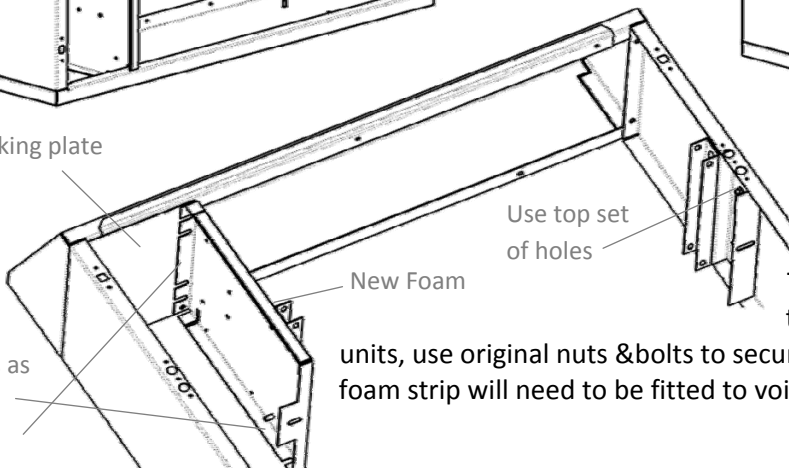

Use top set of holes

New Foam

Refit void & non void brackets as shown. The Void blanking plate fits between the top section & void bracket on sloping top units, use original nuts & bolts to secure the void bracket to the back panel. New foam strip will need to be fitted to void bracket & rear of heat exchanger.

Refit the motor plate, filter and heat exchanger

The air vent and drain plugs on the connection end of the heat exchanger on all wall and floor mounted units do not need changing over.

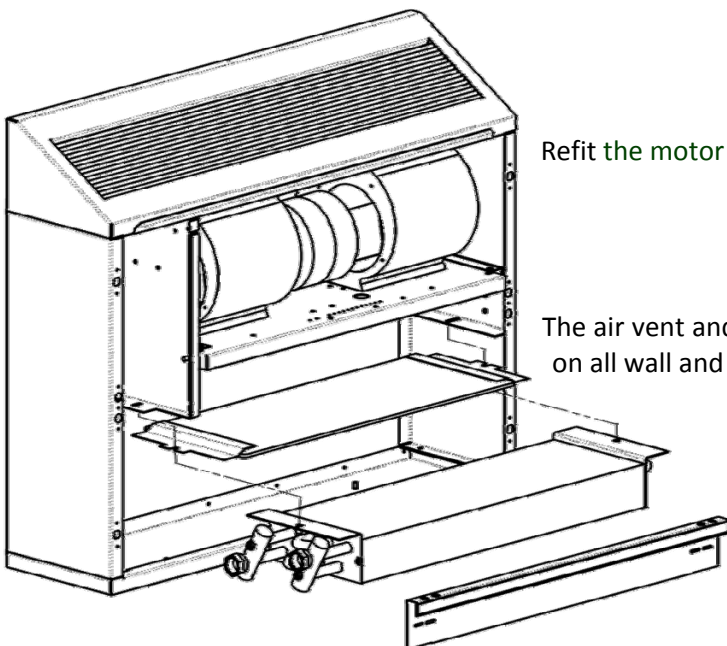

2.6 WIRING

All electrical work should be carried out in accordance with current I.E.E. regulations. See the wiring diagram supplied with the unit for connection details.

All motors are fitted with internal self-resetting thermal overload protection (see note below) and are equipped with a motor plate mounted Anti-surge fuse (see spares list). All units are supplied with a 2 metre length of 3 core cable as a flying lead. This is normally coiled within the unit.

The customer should drill and gland to suit the installation. The supply should be wired through a suitable means of isolation such as a fused spur box or similar. Recommended fuse is not more than 3A (for standalone unit).

2.7 ELECTRIC MOTOR PROTECTION

On ceiling mounted and reverse airflow applications where the fan motor is switched off for long periods, with hot water still circulating through the heat exchanger in excess of 82 C (180 F), it is recommended that a system be employed which automatically closes the hot water supply valve to prevent damage to the electric motor due to overheating.

3. ELECTRICAL DATA

UNIT	SPEED	AIRFLOW (L/S)	EC POWER DRAW (W)	EC SFP (W/L/S)
Bel 30	L	99	13	0.13
	N	124	20	0.16
	H	155	34	0.22
Bel 40	L	89	11	0.12
	N	112	16	0.14
	H	140	27	0.19
Bel 60	L	108	15	0.14
	N	184	53	0.29
	H	223	84	0.38
Bel 75	L	110	19	0.17
	N	189	23	0.12
	H	280	53	0.19
Bel 90	L	120	18	0.15
	N	231	34	0.15
	H	317	73	0.23
Bel 115	L	128	18	0.14
	N	188	23	0.12
	H	248	40	0.16
Bel 150	L	180	22	0.12
	N	289	58	0.20
	H	329	80	0.24

3.1 CONTROL WIRING

The wiring for internal control options is sited on the motor plate. Wiring from the motor plate to casing control options is via split connector break plugs. Customer wiring should be made to the Customer Connection Box for other than the flying lead. Wiring to other than this point may result in voiding of the warranty.

A wiring diagram showing customer connections is included with each unit.

For wiring other than that specified on the Customer's order, the SPC Technical Department should be contacted.

3.2 MOTOR WIRING

The motors are Electronically Controlled. They have a 230v AC supply but are controlled via a 10v DC signal. A circuit board on the motor plate has three potentiometers fitted which give the low/normal/high speed.

If only one speeds is specified this will be normal unless otherwise stated.

3.3 COMMON CONTROL OPTIONS

	REFERENCE **	FUNCTION	
Thermostat	T-1	On-off	
	T-2	Change speed	
	LTC	Low water temperature fan cutout	
	ALTC	Adjustable low water temperature fan cutout (remote)	
Switches	RS-1	On-off	
	RS-2	Summer-winter	
	RS-3	Change speed (3 speeds	

**Additional References: Motor plate mounted = B, Case mounted = C, Remote = R

3.4 THERMOSTATIC OPERATION

The T1 and T2 Thermostats both have graduated scales to cover their range of operation. Since the thermostatic bulb is frequently unit mounted it may be offset by various amounts from the measured room temperature.

Set the knob at mid-range and adjust to suit comfort conditions within the room.

The range corresponds to a sensed temperature range of 10°C to 30°C.

T1 and T2 are adjustable and determine the comfort room temperature range. Set T2 for the low and T1 for the high point. Example: T2 16°C and T1 20°C.

The LTC is not adjustable (45°C) and provides a fan cut-off for the situation when the water temperature is not sufficiently high to provide warm blown air from the fan convector. The LTC is mounted at the non-void end of the unit, and is screwed to a copper disc which is brazed onto a return bend of the coil.

3.5 SWITCH OPERATION

The RS1 switches do not in themselves isolate the unit.

The RS2 Summer-Winter switch provides an override for the LTC and T1 (where fitted), enabling the fan to operate in the summer, for air re-circulation.

The RS3 Change Speed Switch delivers one of three voltage tapings to the motor. Where used in a remote application care should be taken when wiring into the customer connection box to ensure correct sequencing

4 MAINTENANCE

4.1 GENERAL

WARNING! ELECTRICALLY ISOLATE THE UNIT PRIOR TO WORK COMMENCING

4.2 FILTER

The AF3 air filter is motor plate mounted as standard. The filter is held in place between 2 brackets and is removed by sliding it out. The AF1 filter, where specified, is fitted underneath the heat exchanger and can be slid in and out of two short side rails. The AF2 inlet air filter can be specified as either internal or external and is fitted on the air inlet grille.

Filters should be gently tapped to remove most of the accumulated dust and either vacuumed clean or washed in lukewarm water with detergent. Rinse in clean water and allow to dry naturally before replacement.

If an inlet plenum is fitted, the filter is removed by dismantling the access panel to gain access.

4.3 COIL

Remove access panel and clean the coil with a brush or by vacuuming, taking care not to damage the coil surfaces.

4.4 FAN SET

The motor has sealed for life sleeve bearings, which under normal circumstances require no user maintenance. The motor deck is accessed by means of the access panel and is readily removed if required. Occasional vacuuming or cleaning of the motor plate is recommended.

4.5 FUSING

Fan motor - Anti-surge 20mm x 5mm 2A to BS4265/IEC127
(see wiring diagram).

4.6 SPARES

- Fuses - as above
- Filters - quote model number (BEL 40/60 etc.) or unit width. Units manufactured pre 1995 will require different filters to later units
- Controls - as specification
- Motor - quote model number on motor plate
 - Quote motor plate mounted (AF3) or coil mounted (AF1) or grille mounted (AF2).
 - Quote wiring diagram number or marked number if possible.

5. FAULT FINDING

5.1 NO FAN OPERATION

Check fuse on motor plate.
Check power supply to unit.
Check loose wiring and breaker plugs or damage to wiring.
Check switches
Check impellers run freely.

5.2 NO HEATING

Check thermostat operation (change set point to maximum) where fitted.
Check integrity of wiring.
Check coil vented.
Check hot water to unit.
Check thermostat bulb in airstream.
Check LTC contact on pipe-work or return bend.

6. Waste Electrical and Electronic Equipment (WEEE) Directive

6.1 WEEE Marking

All products that are subject to the WEEE Directive supplied by S & P Coil Products from 2007 are compliant with the WEEE marking requirements. Such products are marked with the "crossed out wheelie bin" WEEE symbol shown here.



S & P Coil Products Limited WEEE Certificate No: **WEE/KF0742YR**

6.2 Information for Customers

According to the timelines and requirements of European Union member state WEEE legislation, the following customer information is provided for all S & P Coil Products Limited supplied products subject to the WEEE directive.

This symbol on the product or on its packaging indicates that the product must not be disposed of with normal household waste.

Instead, it is your responsibility to dispose of your waste equipment by arranging to return it to a designated collection point for the recycling of waste electrical and electronic equipment. By separating and recycling your waste equipment at the time of disposal you will help to conserve natural resources and ensure that the equipment is recycled in a manner that protects human health and the environment. For more information about how to recycle your S & P Coil Products Limited supplied waste equipment for recycling, please contact our customer services department on +44 (0)1162490044 or customerservice@spcoils.co.uk.



S & P Coil Products Ltd
SPC House, Evington Valley Road, Leicester, LE5 5LU
Tel: (0116) 249 0044 Fax: (0116) 249 0033
e-mail: spc@spcoils.co.uk Web: www.spcoils.co.uk

